

# Impact panel printer FH190SP User's manual

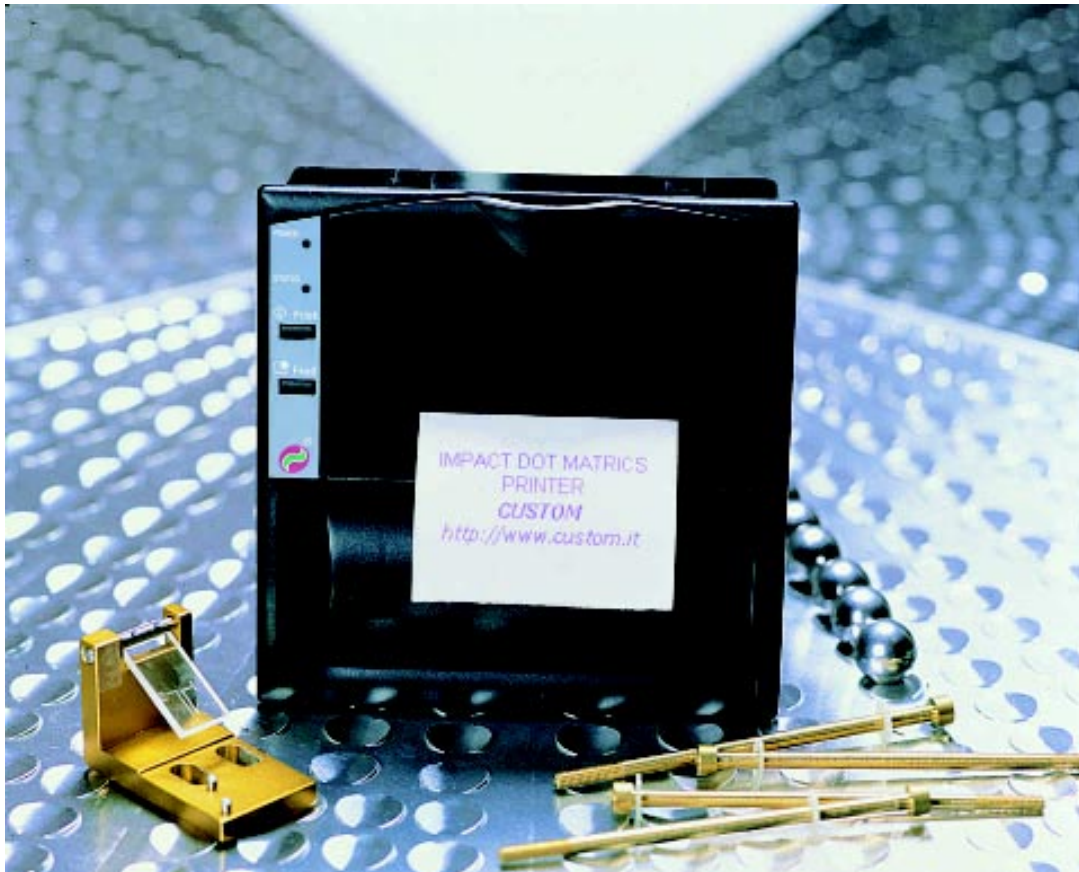

## Printer components

- 1- Print mechanism
- 2- Case
- 3- Paper outfeed
- 4- Paper loading label
- 5- Front panel
- 6- Paper roll compartment
- 7- Keypad
- 8- Feed connector
- 9- Paper winder connector
- 10- Interface connector
- 11- External "Print" key connector

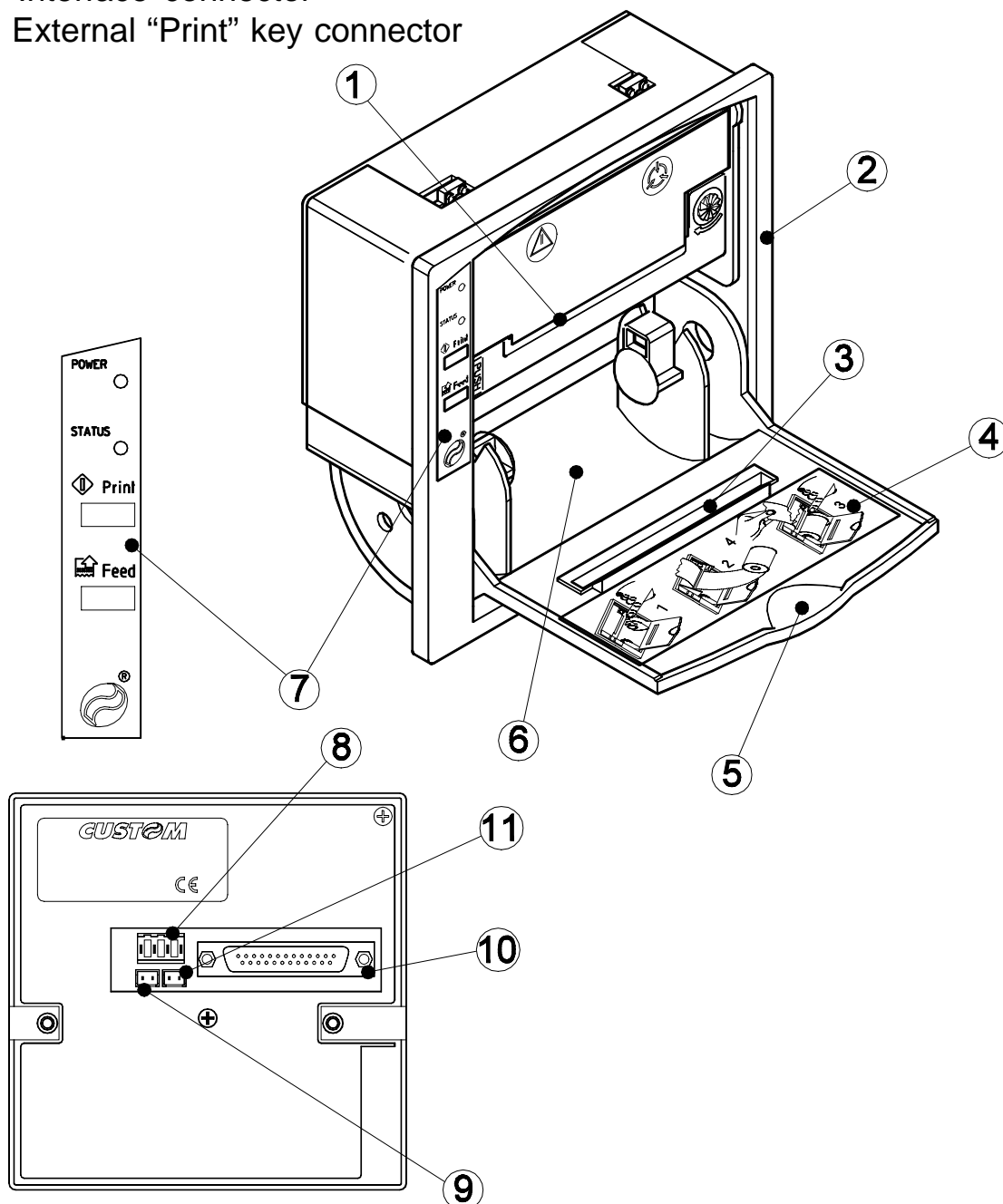

All rights reserved. The reproduction of this manual, either totally or partially, in any form whatsoever, whether it be on paper or through computer processes, is strictly prohibited. CUSTOM ENGINEERING SPA and the resource teams employed in the making of this manual will not be held responsible for any problems arising as a result of improper use of this manual, as they guarantee that the information contained in it has been subjected to careful inspection. Any suggestions regarding errors in its contents or possible improvements will be greatly appreciated. The products are continuously checked and improved. For this reason CUSTOM ENGINEERING SPA reserves the right to modify the information contained in this manual without prior notice.

COD. DOME - FH190SP

REV. 1.20

Copyright © 1998 CUSTOM ENGINEERING SPA – Italy

CUSTOM ENGINEERING SPA

Str. Berettine 2 - 43010 Fontevivo (PARMA) - Italy

Tel. : +39 0521-680111 - Fax : +39 0521-610701

http: [www.custom.it](http://www.custom.it) Email : [support@custom.it](mailto:support@custom.it)

Customer Service Dept.:

Phone: +39 0521-680163 - Fax: +39 0521-680146

E-mail: [support@custom.it](mailto:support@custom.it)

## "CE" Declaration of conformity

**In accordance with standards ISO/IEC Guide 22 and EN 45014**

N°:  
DC0302698

Manufacturer's name: Custom Engineering s.r.l.

Manufacturer's address: Strada Berettine 2  
Fontevivo (Parma)  
Italy

Declares that the product

Product name: Panel printer with impact print mechanism

Product type: FH190SP

Model: FH190SP RS232 / CENTRONICS

is in conformity with the following directives:

Electromagnetic Compatibility Directive 89/336/CEE; 92/31/CEE; 93/68/CEE

In accordance with the following standards:

EN 55022 Classe B	Limits and methods of measuring the characteristics of radio disturbance produced by information technology equipment.	1995
EN 50082-1	Electromagnetic compatibility - General immunity requirements. Part 2: the industrial environment.	1992
EN 61000-4-2	Electrostatic discharge immunity tests. 4KV contact discharge, 8KV air discharge	1995
EN 61000-4-4	Electrical fast transient/burst immunity tests. Power lines DC 0,5KV	1995
ENV 50140	Radio-frequency irradiated electromagnetic fields. Immunity test. 3V/m, 80MHz-1000MHz, 80% 1KHz AM	1993

June 1998

## INTRODUCTION

CONTENTS OF THE MANUAL .....	1
CONVENTIONS USED IN THE MANUAL .....	1
GENERAL INFORMATION REGARDING SAFETY .....	1
UNPACKING THE PRINTER .....	3
GENERAL FEATURES .....	3
DESCRIPTION OF THE PRINTER .....	4

## 1. INSTALLATION AND USE

1.1 CONNECTIONS .....	1-1
1.1.1 Power supply .....	1-1
1.1.2 Paper winder .....	1-2
1.1.3 External Print button .....	1-2
1.2 CONFIGURATION .....	1-2
1.3 AUTOTEST .....	1-4
1.4 HEXADECIMAL DUMP .....	1-4
1.5 MAINTENANCE .....	1-4
1.5.1 Changing the paper roll .....	1-4
1.6 PRECAUTIONS .....	1-5

## 2. INTERFACES

2.1 RS232 SERIAL .....	2-1
2.2 CENTRONICS PARALLEL .....	2-3
2.3 CALENDAR CLOCK (OPTIONAL) .....	2-4
2.3.1 Adjusting the clock through the keypad .....	2-4

## 3. PRINTER FUNCTIONS

3.1 PRINT DIRECTION .....	3-1
3.2 CONTROL CHARACTERS .....	3-2
3.2.1 Custom emulation .....	3-2
3.2.2 ESC/POS emulation .....	3-19
3.2.3 CITIZEN emulation .....	3-38

## 4. TECHNICAL SPECIFICATIONS

4.1 TECHNICAL SPECIFICATIONS .....	4-1
4.2 DIMENSIONS .....	4-2

**5. CHARACTER SETS**

5.1 CHARACTER SETS ..... 5-1

**ATTACHMENT A - ACCESSORIES AND SPARE PARTS**

A.1 ACCESSORIES..... A-1  
    A.1.1 Power supply ..... A-1  
    A.1.2 Paper winder..... A-2  
A.2 SPARE PARTS ..... A-3

## CONTENTS OF THE MANUAL

In addition to the introduction which lists: the conventions used in the manual, general information relative to safety, unpacking of the printer and a brief description of the printer itself highlighting its main features, the manual is split up into the following chapters:

- Chapter 1: Containing the information required for installing and using the printer correctly
- Chapter 2: Containing the specifications of the interfaces
- Chapter 3: Containing the description of the printer command set
- Chapter 4: Containing the technical specifications of the printer
- Chapter 5: Containing the character sets (fonts) used by the printer

## CONVENTIONS USED IN THE MANUAL



### **N.B.**

Gives important information or suggestions relative to the use of the printer



### **WARNING**

The information marked with this symbol must be carefully heeded to safeguard against damaging the printer



### **DANGER**

The information marked with this symbol must be carefully heeded to safeguard against injury to the operator

## GENERAL INFORMATION REGARDING SAFETY

- Read and keep the following instructions.
- Observe all warnings and follow all instructions attached to the printer.
- Before cleaning the printer, disconnect the feed cable.
- Clean the printer with a damp cloth. Do not use liquid or spray products.
- Do not operate the printer near to water.
- Do not place the printer on unsteady surfaces. It could fall and get seriously damaged.

- Use the type of electricity supply marked on the printer label. In the event of uncertainty, contact the seller.
- Position the printer in such a way as to ensure that the cables connected to it will not be damaged.
- Ensure that the maximum absorbed current of the printer does not exceed the maximum acceptable current for the type of feed cable used.
- Do not put objects of any kind inside the printer as they could cause a short circuit or damage parts which could affect its performance.
- Do not spill liquids on the printer.
- Do not carry out technical operations on the printer with the exception of the scheduled maintenance operations specifically indicated in the user's manual.
- Disconnect the printer from the electricity supply and have it repaired by a specialized technician should any of the following conditions occur:
  - A. The feed connector has been damaged;
  - B. LIQUID has penetrated to the inside of the printer;
  - C. The printer has been exposed to rain or water;
  - D. The printer is not operating normally despite the instructions in the user's manual having been followed;
  - E. The printer has been dropped and its case damaged;
  - F. The performance of the printer is poor;
  - G. The printer does not work.



## UNPACKING THE PRINTER

Remove the printer from the box, taking care not to damage the packing material, as it could be needed for future transportation of the machine.

Ensure that all the components illustrated are in fact present and that they are in perfect condition. If this is not the case, contact the after-sales assistance department immediately.

Printer  
Manual (or Cdrom)  
Paper roll(inside the printer)  
Long screws

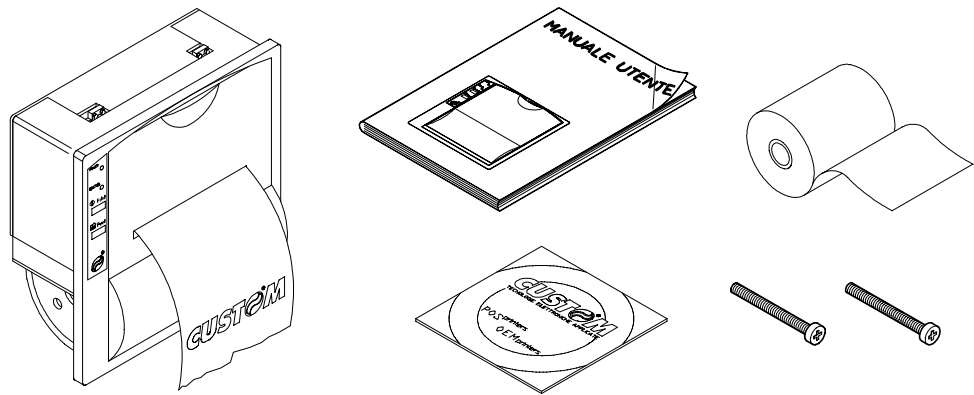

(Fig.1)



### N.B.

Before using the long screws, read the note to paragraph 4.2.

## GENERAL FEATURES

The FH190SP is a printer which, in addition to having an innovative design, guarantees high performance and is reliable and user-friendly.

For these reasons it is the ideal solution for applications which require the immediate printing of data on a ticket, whether they be of an industrial, professional or laboratory nature. Typical fields of application are: weighing systems, receipts (not for tax purposes) as well as for security, controlling and diagnostics purposes.

It is equipped with a impact print mechanism and uses 57.5 mm paper rolls. The FH190SP printer is so compact and lightweight that it can be installed extremely easily on any type of equipment.

There are already two interfaces on the card: RS232 serial and centronics parallel. To select one of the two interfaces, move some of the jumpers.

There is a 1 Kbyte reception buffer. It can also be equipped with a Real Time Clock.

**DESCRIPTION OF THE PRINTER**

The FH190SP printer has an ABS casing (1) with a front cover (2) which opens to allow access to the paper roll and print head. The control panel is located on the front (3) and has a PRINT key, a FEED key and two LEDs: Power and Status.

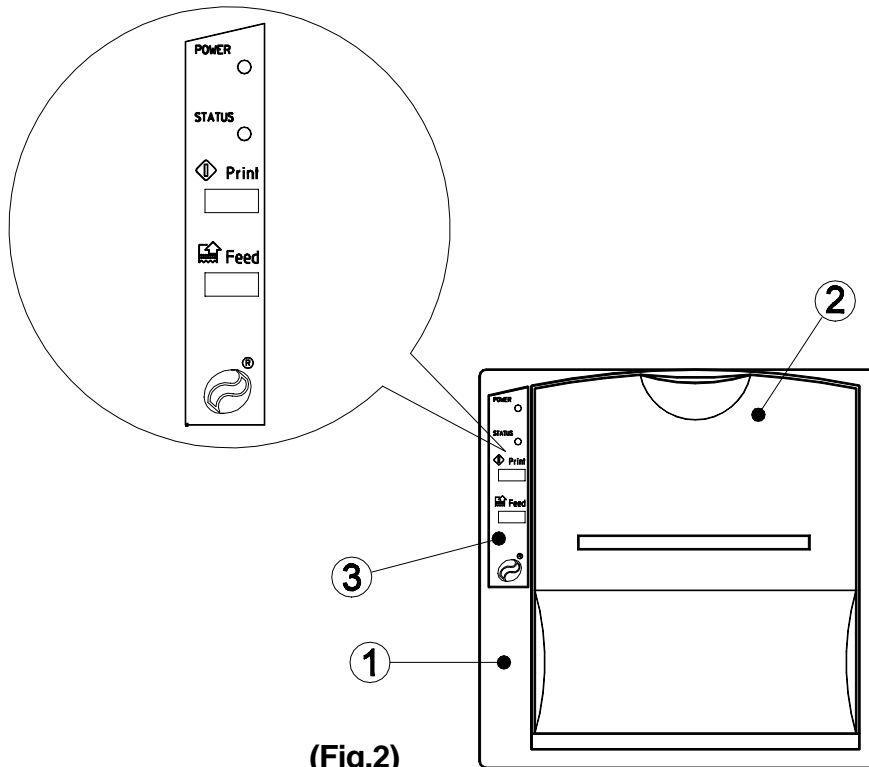

(Fig.2)

- PRINT key. When pressed, it causes the transmission, in serial, of the control character “\$0D”, if this has been enabled at the printer setup stage. The J6 connector, which can be used for connecting an external key, is parallel to the PRINT key (fig.1.1).
- FEED key. When this is pressed the paper feeds forward manually. If this key is pressed briefly, when the RTCK option is installed, the date and time of day is printed (if the printing function was enabled from setup).
- The POWER LED indicates that the the printer is receiving a digital power supply.
- The STATUS LED, when lit, signals that the printer motor is ON.

# 1. INSTALLATION AND USE

## 1.1 CONNECTIONS

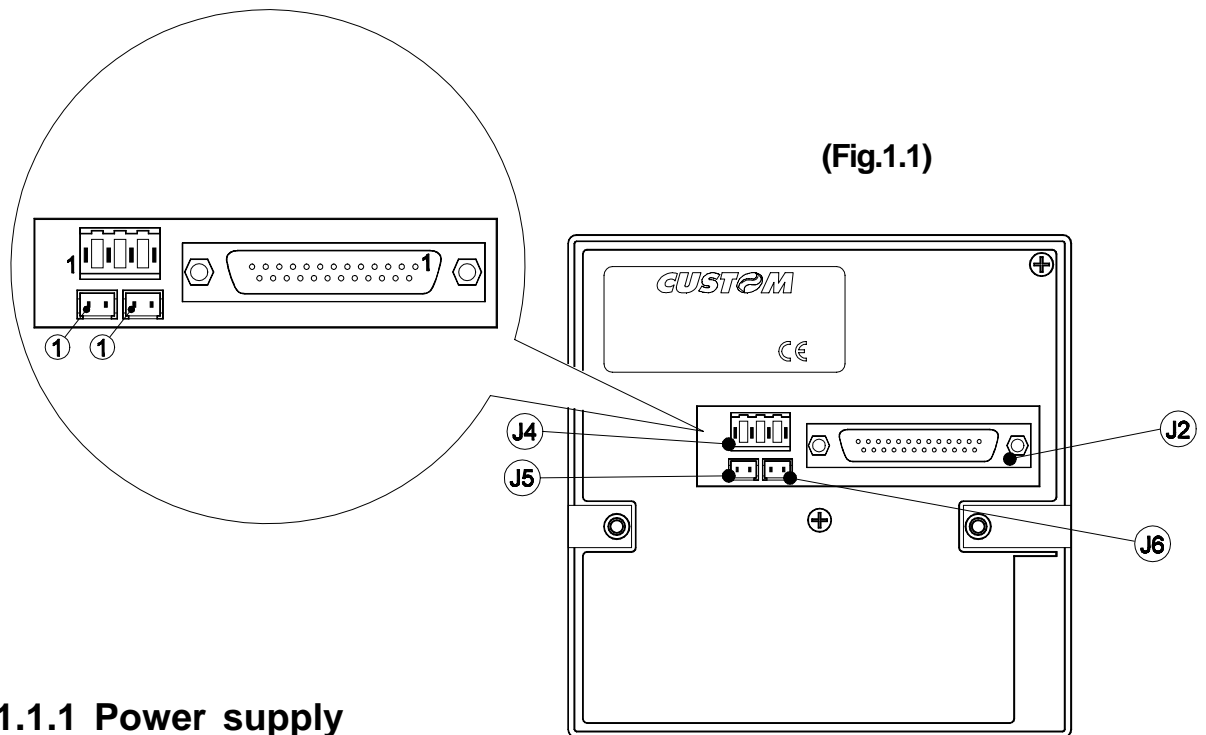

### 1.1.1 Power supply

The FH190SP printer is equipped with a standard 4-pin male AMPMODU1-type connector (J4). The signals on the connector pins are as follows:



#### WARNING

Respect the polarity of the power supply

5V VERSION		
PIN	SIGNAL	NOTES
1	GND	
2	GND	
3	+VT: from 4.5 to 5.5 Vdc	needle printer power supply
4	+VDC: 5 Vdc $\pm$ 7%	logic card power supply

(Tab.1.1)

VERSION 9 - 40V		
PIN	SIGNAL	NOTES
1	GND	
2	GND	
3	from 9 to 40 Vdc	
4	N.C.	

(Tab.1.2)

## 1.1.2 Paper winder

The connector J5 (fig.1.1) is used to supply the external paper winder. The positions and functions of the signals are shown in Table 1.3.

Pin	Signal
1	MOTOR +
2	MOTOR -

(Tab.1.3)

## 1.1.3 External Print button

An external Print key (fig.1.1) can be connected to connector J6. The polarity and functions of the signals are shown in Table 1.4.

Pin	Signal
1	PRINT
2	GND

(Tab.1.4)

## 1.2 CONFIGURATION

The FH190SP enables the configuration of the printer default parameters. This procedure is enabled by holding down the PRINT and FEED keys while switching on, with the jumper JP2 (Fig. 2.1) present on the printer card open.

## 1. INSTALLATION AND USE

After this, each time the PRINT key is pressed, the parameter is modified and its current value is printed. Once the required value has been obtained, press the FEED key to proceed to the next parameter, and so on. Once all the parameters have been run through, the printing of a message signals the end of the setting procedure. The parameters affected during configuration are:

- **Emulation type:** Custom Emulation<sup>D</sup>, ESC/POS™ Emulation, iDP-560 Emulation.
- **Print direction:** Normal<sup>D</sup> or Reverse.
- **Character dimensions:** small<sup>D</sup>, double width, double height, expanded.
- **Character set:** Font1<sup>D</sup> or Font2.
- **Automatic feed:** CR disabled or CR enabled<sup>D</sup>.

*If present serial interface :*

- **Baud Rate:** 38400, 19200, 9600<sup>D</sup>, 4800, 2400, 1200, 600, 300.
- **Protocol:**
  - 8, N, 1<sup>D</sup> (8 bit, parity none, 1 Stop bit)
  - 8, E, 1 (8 bit, parity even, 1 Stop bit)
  - 8, O, 1 (8 bit, parity odd, 1 Stop bit)
  - 7, N, 2 (7 bit, parity none, 2 Stop bit)
  - 7, E, 1 (7 bit, parity even, 1 Stop bit)
  - 7, O, 1 (7 bit, parity odd, 1 Stop bit)

*If present parallel interface :*

- **Length of data:** 7, 8<sup>D</sup> bits/char.
- **Flow control:** CTS-RTS<sup>D</sup>, XON-XOFF.
- **PRINT Key setting:** Null<sup>D</sup> PRINT key, Enables \$0D character transmission on pressing PRINT key.
- **Reception buffer dimension:** 1K Byte<sup>D</sup>, 24 Byte.

*If present RTCK (real time clock) :*

- **Real Time Clock setting:** Enables RTCK<sup>D</sup>, disables RTCK.
- **Printing seconds setting:** Enables seconds, disables seconds<sup>D</sup>.
- **Setting of printing date/hour by keys <sup>(1)</sup>:** Enables printing date/hour<sup>D</sup>, disables printing date/hour.

Please note: the parameters marked with the symbol <sup>D</sup> represent the default values.

<sup>(1)</sup> **Note:** To print date/hour pressing the FEED key briefly.

# 1. INSTALLATION AND USE

The settings made are saved on the EEPROM (non volatile memory). When reset, on pressing the PRINT key the printer re-initializes.

## 1.3 AUTOTEST

To run the autotest, hold down the FEED key, while switching on the printer. The autotest causes the printing of the printer's current setting data and the printing of the complete ASCII character set.

## 1.4 HEXADECIMAL DUMP

After completing the autotest procedure, the printer enters Hexadecimal Dump mode. This function is used for the diagnostics of characters received in serial or parallel. In fact, these are printed in hexadecimal code together with the corresponding Ascii code.

## 1.5 MAINTENANCE

### 1.5.1 Changing the paper roll

To change the paper roll, proceed as follows:

- 1) Open the printer cover and press down the swinging support of the print mechanism at the point marked PUSH;
- 2) Insert the end of the roll in the slit of the print mechanism;
- 3) Press the FEED key; a few centimetres of paper automatically feed out of the printer;
- 4) Re-close the swinging support, tear off the paper and re-close the cover.

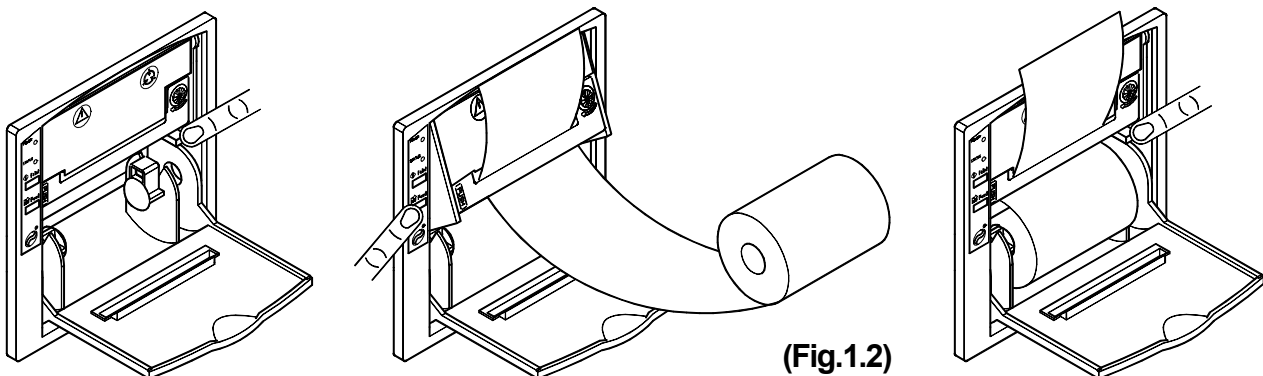



### **WARNING**

Before inserting the paper, ensure that it is cut evenly

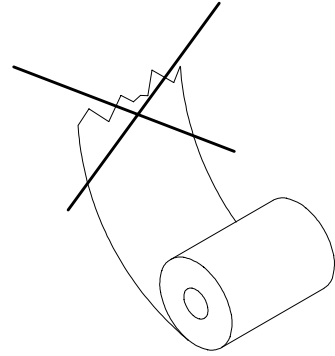

### 1.6 PRECAUTIONS



#### **WARNING:**

- Do not print without paper and/or ink ribbon; this leads to the rapid deterioration of the print needles.
- Do not pull the printer carriage manually when it is switched on.
- Do not put objects inside the printer.
- Avoid blows to any part of the printer, both during and after installation.

## 2. INTERFACES

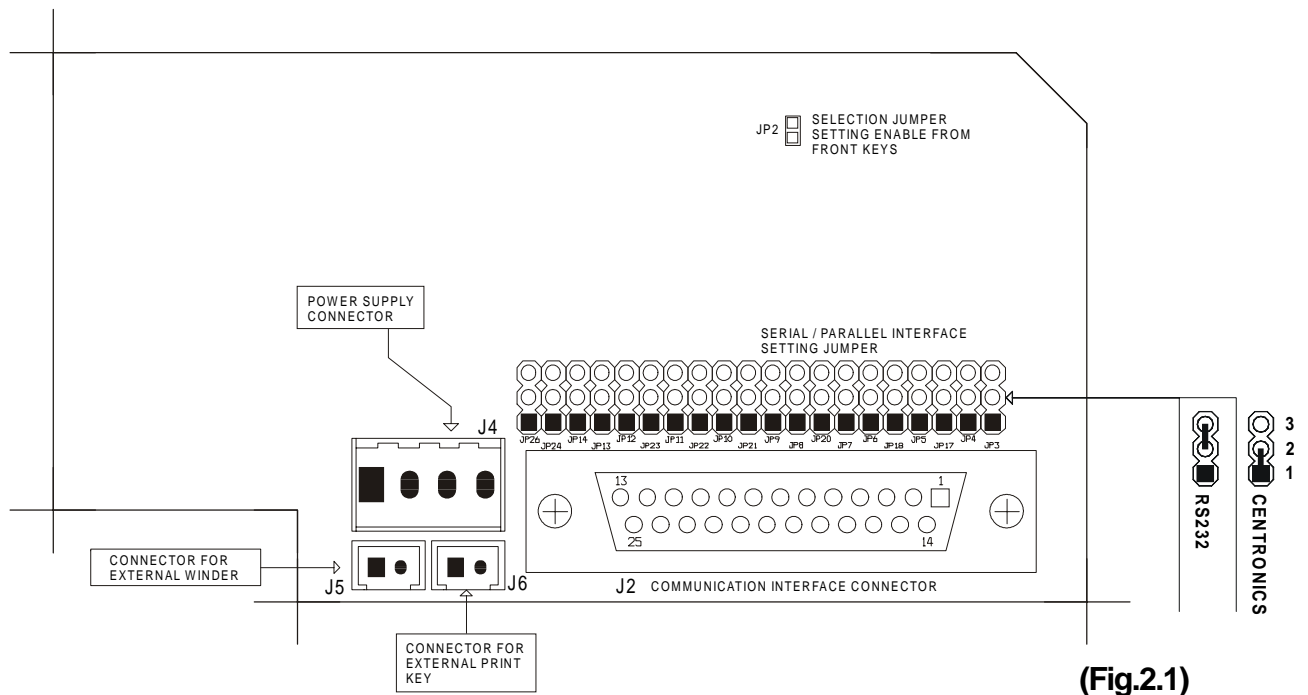

(Fig.2.1)

The selection of the RS232 or CENTRONICS interface is made through a 20 contact strip: when the strip is placed in position 1-2 (fig.2.1) the Centronics standard interface is selected; when, on the other hand, the strip is placed in position 2-3 the RS232 serial interface is selected.

### 2.1 RS232 SERIAL

The printer has an RS232 serial interface and is connected by means of a 25-pin female rectangular connector. In the serial protocol, the signals which distinguish the communication are TXD, RXD, and RTS if the RTS/CTS protocol has been selected while, if the XON/XOFF protocol has been selected, the signals are TXD and RXD.

In the following table, the signals present on the connector are listed:

PIN	SIGNAL	DIRECTION	DESCRIPTION
1	NC	-	
2	TXD	Output	Data transmission
3	RXD	Input	Data reception
4	RTS	Output	Same as DTR signal
7	SG	-	Ground Signal



PIN	SIGNAL	DIRECTION	DESCRIPTION
20	DTR	Output	Control signal
17	GND	-	Ground

(Tab.2.1)

The following diagrams show examples of connections between the printer and the Personal Computer using 25 & 9 pin female rectangular connectors.

(Fig.2.2)

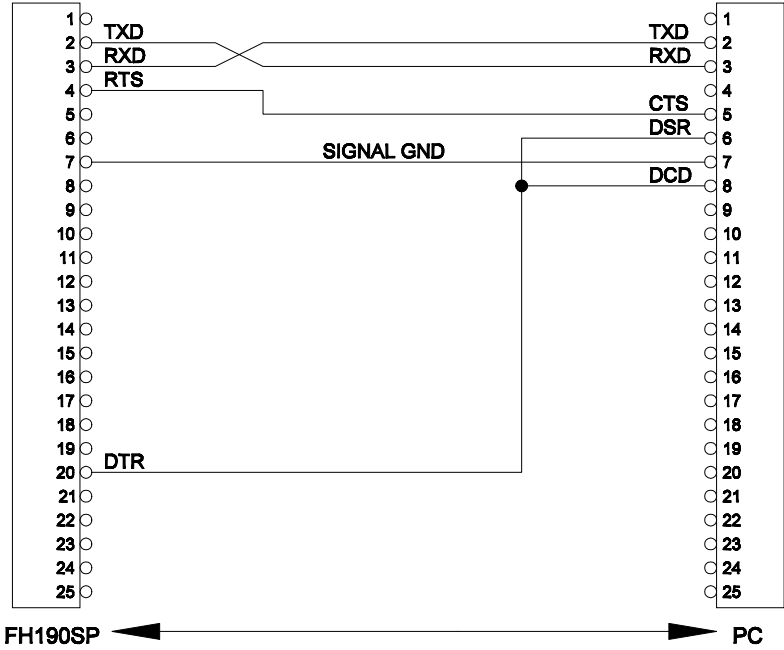

(Fig.2.3)

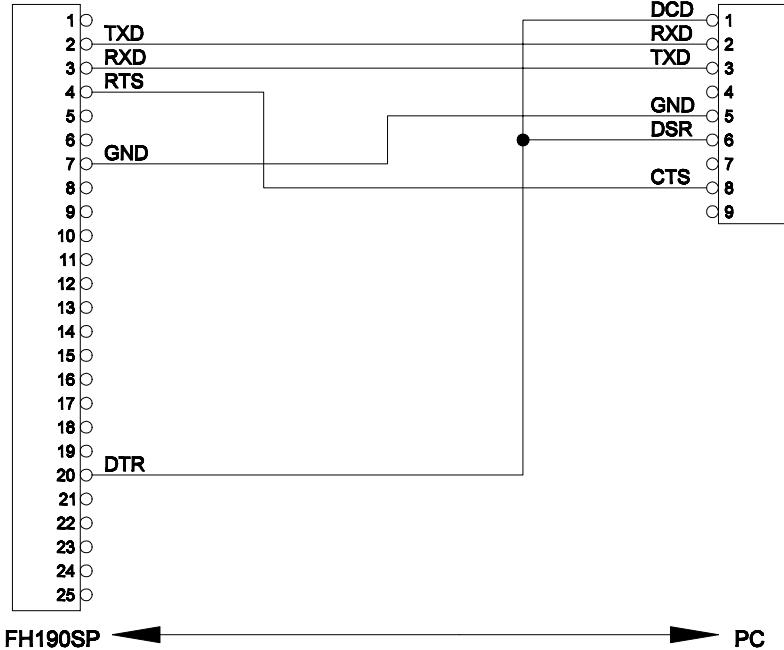

## 2. INTERFACES

### 2.2 CENTRONICS PARALLEL

The printer has a Centronics parallel interface and is connected by means of a 25-pin female rectangular connector. In the parallel communication the signals which can be used are:

- 1) 7 or 8 bit data buses;
- 2) STROBE signal indicating the validity of the data;
- 3) the BUSY signal which indicates that the printer is ready to receive data;
- 4) the ACK signal for data reading acknowledgement.

In the following table, the signals present on the connector are listed:

<b>PIN</b>	<b>SIGNAL</b>	<b>DIRECTION</b>
<b>1</b>	Strobe	Input
<b>2</b>	Data bit 0	Input
<b>3</b>	Data bit 1	Input
<b>4</b>	Data bit 2	Input
<b>5</b>	Data bit 3	Input
<b>6</b>	Data bit 4	Input
<b>7</b>	Data bit 5	Input
<b>8</b>	Data bit 6	Input
<b>9</b>	Data bit 7	Input
<b>10</b>	ACK	Output
<b>11</b>	BUSY	Output
<b>12</b>	LOW	Output
<b>13</b>	HIGH	Output
<b>14</b>	NC	-
<b>15</b>	FAULT	Output
<b>16</b>	RESET	Input
<b>17-25</b>	GND	-

(Tab.2.2)

### 2.3 REAL TIME CLOCK (option)

The Real Time Clock is available as an option. Printing and adjustment of the clock are managed by a series of control characters, described as follows.



#### **N.B.**

For the real time clock control characters, please refer to description of the printer command sets in chapter 3.

#### 2.3.1 Adjusting the clock through the keypad

The time and date can be adjusted using the PRINT and FEED keys on the printer's front panel. To set, proceed as follows:

- While holding down the FEED key, press the PRINT key. The printer will print the time and date with an arrow indicating the digit to be modified;
- Each time the PRINT key is pressed, the digit marked by the arrow will increase and an updated version will be printed;
- To proceed to modify another digit, press the FEED key again. Each time the printer will print the updated time and date, highlighting with an arrow the currently selected digit;
- To terminate the setting procedure, press PRINT and FEED at the same time.

### 3. PRINTER FUNCTIONS

#### 3.1 PRINT MODES

The FH190SP has two print modes, selectable through the control characters: normal and reverse.

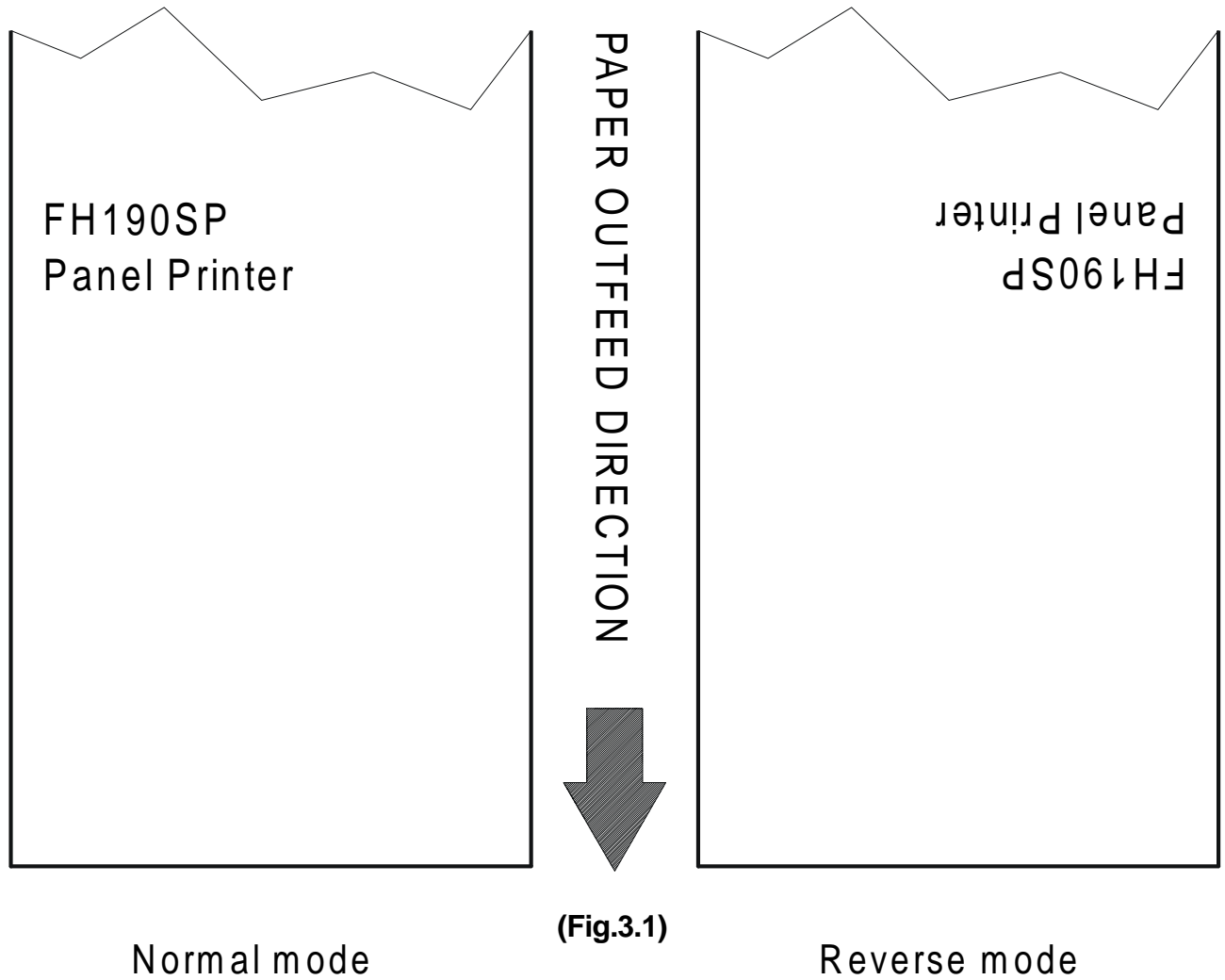

#### 3.2 CONTROL CHARACTERS

The command table lists all the commands for the management of the FH190SP printer functions. These commands can be transmitted to the printer with both the serial and parallel interfaces; if, however, the parallel interface is being used, the user will not be able any kind of response, as this interface is uni-directional.

The commands can be transmitted to the printer at any moment, but they will only be carried out when the characters previously transmitted have been printed or the commands previously transmitted have been carried out. There are no commands with priority status; all the commands are carried out when the circular buffer is free to do so

##### 3.2.1 Custom emulation

(Tab.3.1)

COMMAND TABLE

ASCII Comm.	HEX Comm.	Description
	\$00	Small character printing
	\$01	Double width printing
	\$02	Double height printing
	\$03	Expanded printing
	\$04	Restore small character printing
	\$0A	Forward feed one line
	(n) \$0B	Forward feed (n) lines
	\$0D	Print line buffer
	\$0F	Set CRLF mode
	\$11	Graphic mode
	\$12	Print time and date
	\$13	Set time and date
	\$14	Transmit time and date in serial
	\$17	Print 1st programmable character
	\$18	Print 2nd programmable character
	\$19	Print 3rd programmable character
	\$1A	Print 4th programmable character

### 3. PRINTER FUNCTIONS

ASCII Comm.	HEX Comm.	Description
	\$1C	Print 5th programmable character
	\$1D	Print 6th programmable character
	\$1E	Print 7th programmable character
	\$1F	Print 8th programmable character
ESC R	\$1B \$52	Set reverse mode printing
ESC N	\$1B \$4E	Set normal mode printing
ESC @	\$1B \$40	Reset the printer
ESC D	\$1B \$44	Enter date in print buffer
ESC T	\$1B \$54	Enter time in print buffer
ESC U	\$1B \$55	Enter date (mm :dd :yy) in print buffer
ESC S	\$1B \$53	Enable printing of seconds
ESC B	\$1B \$42	Set font 1
ESC b	\$1B \$62	Set font 2
(aa) ESC r	(aa) \$1B \$72	Read data at an address (aa)
(aadd) ESC w	(aadd) \$1B \$77	Write data (dd) in an address (aa)
(dd) ESC G	(dd) \$1B \$47	Write the value (dd) in option register
(dd) ESC M	(dd) \$1B \$4D	Write the value (dd) in the print mode
ESC p	\$1B \$70	Transmit option register in serial
ESC m	\$1B \$6D	Transmit print mode in serial
ESC s	\$1B \$73	Transmit next character in serial
(dd) ESC a	\$1B \$61	Select number of dot spaces
ESC J (n)	\$1B \$4A	Load programmable character

### 3. PRINTER FUNCTIONS

A more detailed description of the individual commands now follows.

#### 00H

[Name]	<b>Small character print</b>
[Format]	ASCII - Hex 00 Decimal 0
[Description]	The printer prints in small(normal) format
[Notes]	<ul style="list-style-type: none"><li>• The commands from 00H to 09H do not erase the print buffer</li><li>• The commands that modify the direction of the characters are only enabled at the beginning of the line</li></ul>
[Default]	Setting in the option register using the front keys
[Reference]	<b>01H, 02H, 03H, 04H</b>
[Example]	

#### 01H

[Name]	<b>Double width print</b>
[Format]	ASCII - Hex 01 Decimal 1
[Description]	The printer prints in double width format
[Notes]	<ul style="list-style-type: none"><li>• The commands from 00H to 09H do not erase the print buffer</li><li>• The commands that modify the direction of the characters are only enabled at the beginning of the line</li></ul>
[Default]	Setting in the option register using the front keys
[Reference]	<b>00H, 02H, 03H, 04H</b>
[Example]	

#### 02H

[Name]	<b>Double height print</b>
[Format]	ASCII - Hex 02 Decimal 2
[Description]	The printer prints in double height format
[Notes]	<ul style="list-style-type: none"><li>• The commands from 00H to 09H do not erase the print buffer</li></ul>

### 3. PRINTER FUNCTIONS

- The commands that modify the direction of the characters are only enabled at the beginning of the line

[Default] Setting in the option register using the front keys

[Reference] **00H, 01H, 03H, 04H**

[Example]

#### 03H

[[Name] **Expanded printing**

[Format] ASCII -  
Hex 03  
Decimal 3

[Description] The printer prints in expanded character mode

- [Notes]
- The commands from 00H to 09H do not erase the print buffer
  - The commands that modify the size of the characters are only enabled at the beginning of the line

[Default] Setting in the option register using the front keys

[Reference] **00H, 01H, 02H, 04H**

[Example]

#### 04H

[Name] **Reset small character print**

[Format] ASCII -  
Hex 04  
Decimal 4

[Description] The printer resumes printing with small characters

- [Notes]
- The commands from 00H to 09H do not erase the print buffer
  - The commands that modify the size of the characters are only enabled at the beginning of the line

[Default] Setting in the option register using the front keys

[Reference] **00H, 01H, 02H, 03H**

[Example]]



#### 0AH

[Name]	<b>Forward feed one line</b>
[Format]	ASCII - Hex 0A Decimal 10
[Description]	Forward feeds one line equivalent to a line of print
[Notes]	<ul style="list-style-type: none"><li>• This command prints the contents of the buffer</li></ul>
[Default]	
[Reference]	<b>0BH</b>
[Example]	

#### (n) 0BH

[Name]	<b>Forward feed (n) lines</b>
[Format]	ASCII - Hex 0B Decimal 11
[Description]	Carries out the number of line feeds specified in n
[Notes]	<ul style="list-style-type: none"><li>• The number must be ASCII and between 0 and 9 (when n=0 the command is ignored)</li><li>• This command erases the line buffer</li></ul>
[Default]	
[Reference]	<b>0AH</b>
[Example]	If you wish to forward feed rapidly by 5 lines, simply transmit: \$35 \$0B (or 5 and the command \$0B)

#### 0DH

[Name]	<b>Print the line buffer</b>
[Format]	ASCII - Hex 0D Decimal 13
[Description]	This command prints the line buffer
[Notes]	<ul style="list-style-type: none"><li>• If the buffer is empty, the command is ignored</li><li>• If the CRLF option is set, this command is ignored and the printer only prints when the command \$0A is transmitted</li></ul>

### 3. PRINTER FUNCTIONS

[Default]

[Reference] **0FH**

[Example]

#### **0FH**

[Name] **Set CRLF mode**

[Format] ASCII -  
Hex 0F  
Decimal 15

[Description] It inhibits the command \$0D, maintaining only the command \$0A enabled for printing.

[Notes]

- To disable this option, reset the printer
- This command erases the line buffer
- When the printer is switched on, the default value is in the Option Register

[Default] Setting in the option register using the front keys

[Reference] **0DH**

[Example]

#### **11H**

[Name] **Graphic mode**

[Format] ASCII -  
Hex 11  
Decimal 17

[Description] Enables graphic mode:  
one line in 24 column mode is equivalent to 144 horizontal dots divided into 24 6-dot blocks; one line in 40 column mode is equivalent to 240 horizontal dots divided into 40 6-dot blocks.

[Notes] To print in graphic mode, send the command \$11 at the beginning of each line. The byte pattern in the graphic configuration is:

**X R P6 P5 P4 P3 P2 P1**  
**D7 D6 D5 D4 D3 D2 D1 D0**

where:

**X** is not used (we recommend 0);

**R** must be set at level 1;

**P1,,P6** are the data of the graphic dots (1 prints, 0 does not print).

### 3. PRINTER FUNCTIONS

The bit P6 of the string of dots transmitted is printed on the left and the others (P5, P4, P3, P2, P1) follow from left to right as illustrated:

**The 1st byte ✕**    **The 2nd byte ✕**    **The 3rd byte ✕**  
P6 P5 P4 P3 P2 P1    P6 P5 P4 P3 P2 P1    P6 P5 P4 P3 P2 P1

[Default]

[Reference]

[Example]

To print a line of dots, transmit:

\$11, n x \$7F (where n is the number of characters per line),  
\$0D.

To print an empty line, transmit:

\$11, \$40, \$0D.

#### 12H

[Name]

**Print the time and date**

[Format]

ASCII    -

Hex       12

Decimal   18

[Description]

This prints the time and date in the following format:

hh : mm       dd - mm - yy

If the seconds option is enabled, the format will be:

hh : mm : ss dd - mm - yy

[Notes]

- This command resets the line

[Default]

[Reference]

**13H, 14H**

[Example]

#### 13H

[Name]

**Set the time and date**

[Format]

ASCII    -

Hex       13

Decimal   19

[Description]

This command sets the time and date in two possible ways: the first uses the 24-hour clock and the second the 12-hour antemeridian and postmeridian clock. To set the time in the first way, transmit the 10 ASCII characters relative to the time and date followed by \$13. To set the time in the second way, transmit the 10 ASCII characters relative to the time and date

### 3. PRINTER FUNCTIONS

preceded by "A" or "P" and followed by \$13.

[Notes] • It is advisable to transmit the command \$0D first, in order to empty the print buffer

[Default]

[Reference] **12H, 14H**

[Example] To set the time 12:45 on 19-01-93, send the following sequence:

```
1 2 4 5 1 9 0 1 9 3 $13
$31 $32 $34 $35 $31 $39 $30 $31 $39 $33 $13
```

To set the time A12:45 on 19-01-93 send the following sequence:

```
A 1 2 4 5 1 9 0 1 9 3 $13
$41 $31 $32 $34 $35 $31 $39 $30 $31 $39 $33 $13
```

#### 14H

[Name] **Transmit the time and date in serial**

[Format] ASCII -  
Hex 14  
Decimal 20

[Description] Transmit the time and date on the serial port in the format of 11 ASCII characters: hour/minutes/day/month/year + (CR) \$0D

[Notes]

[Default]

[Reference] **12H, 13H**

[Example]

#### 17H,...1FH

[Name] **Print the 1st (...8th) programmable character**

[Format] ASCII -  
Hex 17, ...1F  
Decimal 23, ...31

[Description] This command causes the printing of the corresponding programmable character.

[Notes]

### 3. PRINTER FUNCTIONS

[Default] BIT MAP contained in flash  
[Reference] **17H, 18H, 19H, 1AH, 1CH, 1DH, 1EH, 1FH**  
[Example]

#### **ESC R**

[Name] **Set the printer in reverse mode**  
[Format] ASCII ESC R  
Hex 1B 52  
Decimal 27 82  
[Description] Selects reverse mode printing: the ticket feeds out of the printer with the printing the right way up, running from left to right  
[Notes]  
[Default] Setting in the option register using the front keys  
[Reference] **ESC N**  
[Example]

#### **ESC N**

[Name] **Set normal mode printing**  
[Format] ASCII ESC N  
Hex 1B 4E  
Decimal 27 78  
[Description] Selects normal mode printing: the ticket feeds out of the printer with the printing upside down, running from right to left  
[Notes]  
[Default] Setting in the option register using the front keys  
[Reference] **ESC R**  
[Example]

#### **ESC @**

[Name] **Reset printer**  
[Format] ASCII ESC @  
Hex 1B 40  
Decimal 27 64

### 3. PRINTER FUNCTIONS

- [Description] Erases all the data in the print buffer and resets the printer mode to the one enabled when the printer was switched on
- [Notes]
- Same as hardware reset
  - Once the command has been transmitted, approx. 1.5 seconds elapse before the printer becomes active again
- [Default]
- [Reference]
- [Example] This can be useful when switching on in order to avoid the transmitting of false characters during initialization by the master device

#### ESC D

- [Name] **Store date in print buffer**
- [Format]
- |         |     |    |
|---------|-----|----|
| ASCII   | ESC | D  |
| Hex     | 1B  | 44 |
| Decimal | 27  | 68 |
- [Description] Enter in the buffer the date of the real time clock fitted inside the printer: the format is dd - mm - yy.
- [Notes]
- The date is printed in 8 characters: if there is not enough room in the print buffer, it will not be printed
  - Does not zero-set the line buffer
- [Default]
- [Reference] **ESC T, ESC U**
- [Example] If you wish to write:  
DATE: 11-09-93 TEST OK  
, transmit DATE: \$1b \$44 TEST OK \$0D  
to print just the date \$1B \$44 \$0D"

#### ESC T

- [Name] **Store time of day in print buffer**
- [Format]
- |         |     |    |
|---------|-----|----|
| ASCII   | ESC | T  |
| Hex     | 1B  | 54 |
| Decimal | 27  | 84 |
- [Description] Enter in the buffer the time of the real time clock fitted inside the printer: the format is hh : mm.

### 3. PRINTER FUNCTIONS

- [Notes]
- The time is printed in 5 characters and if the seconds option is enabled, in 8 characters: if there is not enough space in the buffer, it will not be printed
  - It does not zero-set the line buffer

[Default]

[Reference] **ESC D, ESC U, ESC S**

[Example] If you wish to write:

```
                                TIME: 16:45 TEST OK
, transmit          TIME: $1b $54 TEST OK $0D
to print just the date      $1B $54 $0D
```

#### ESC U

[Name] **Store date (mm-dd-yy) in print buffer**

[Format]

ASCII	ESC	U
Hex	1B	55
Decimal	27	85

[Description] Enter in the buffer the date of the real time clock fitted inside the printer, American style: mm - dd - yy.

- [Notes]
- The date is printed in 8 characters: if there is not enough space in the buffer, it will not be printed
  - It does not zero-set the line buffer

[Default]

[Reference] **ESC D, ESC T**

[Example] If you wish to write:

```
                                DATE: 09-11-93 TEST OK
, transmit          DATE: $1b $55 TEST OK $0D
to print just the date      $1B $55 $0D"
```

#### ESC S

[Name] **Enable printing of seconds**

[Format]

ASCII	ESC	S
Hex	1B	53
Decimal	27	83

[Description] This enables the printing of seconds when the time is asked through the command ESC T

[Notes]

### 3. PRINTER FUNCTIONS

[Default] Setting in the option register using the front keys  
[Reference] **ESC T**  
[Example]

#### **ESC B**

[[Name] **Set font 1**  
[Format] ASCII ESC B  
Hex 1B 42  
Decimal 27 66  
[Description] Select the first character font  
[Notes] • The complete font is printed during the autotest. Some codes are not standard: \$60, \$7B, \$7C, \$7D, \$7E, \$7F, \$8D, \$ED, \$FA, \$FF  
[Default] Setting in the option register using the front keys  
[Reference] **ESC b**  
[Example]

#### **ESC b**

[Name] **Set font 2**  
[Format] ASCII ESC b  
Hex 1B 62  
Decimal 27 98  
[Description] Select the second character font  
[Notes] • The complete font is printed during the autotest. The font contains cyrillic characters  
[Default] Setting in the option register using the front keys  
[Reference] **ESC B**  
[Example]

#### **(aa) ESC r**

[Name] **Read a piece of data at an address (aa)**  
[Format] ASCII aH aL ESC r  
Hex aH aL 1B 72  
Decimal aH aL 27 114



### 3. PRINTER FUNCTIONS

[Description]	Reads a memory location (EEPROM) at address a: aH is the most significant nibble of a expressed in ASCII aL is the least significant nibble of a expressed in ASCII
[Notes]	• There are 256 legible locations (from \$00 to \$FF)
[Default]	The whole memory bank contains the value \$20 by default
[Reference]	<b>ESC w</b>
[Example]	To read the address \$01, transmit the following in ASCII: \$30 \$31 \$1B \$72 If the address \$01 contains \$A5, we will receive: \$41 \$35

#### (aadd) ESC w

[Name]	<b>Write a piece of data (dd) in an address (aa)</b>					
[Format]	ASCII	aH	aL	dH	dL	ESC w
	Hex	aH	aL	dH	dL	1B 77
	Decimal	aH	aL	dH	dL	27 119
[Description]	Saves a piece of data d in address a in the memory (EEPROM): aH is the most significant nibble of a expressed in ASCII aL is the least significant nibble of a expressed in ASCII dH is the most significant nibble of d expressed in ASCII dL is the least significant nibble of d expressed in ASCII					
[Notes]	• There are 256 writable locations (from \$00 to \$FF), the data must be a maximum of \$FF (255) and both the addresses and the data must be expressed in ASCII on two bytes					
[Default]	The whole memory bank contains the value \$20 by default					
[Reference]	<b>ESC r</b>					
[Example]	To save the data \$A5 in the address \$01, transmit: \$30 \$31 \$41 \$35 \$1B \$77					

#### (dd) ESC G

[Name]	<b>Write the value (dd) in the option register</b>			
[Format]	ASCII	dH	dL	ESC G
	Hex	dH	dL	1B 47
	Decimal	dH	dL	27 71
[Description]	Modify the configuration register. (dd) are two ASCII CHARACTERS that represent the hexadecimal code for the			

### 3. PRINTER FUNCTIONS

programming of the register.

(dd)	bit=0	bit=1
<b>bit0</b> : setting of real time clock	disabled	enabled
<b>bit1</b> : print direction	normal	reverse
<b>bit2</b> : -		
<b>bit3</b> : printing of seconds	disabled	enabled
<b>bit4</b> : CR (\$0D)	enabled	disabled
<b>bit5</b> : -		
<b>bit6</b> : font selection	font 1	font 2
<b>bit7</b> : reception buffer	1Kbyte	N° columns

[Notes] • The setting is stored in the EEPROM and assumed as default value the next time the printer is switched on

[Default]

[Reference]

[Example] To send the setting byte 00001001 (\$09):  
\$30 \$39 \$1B \$47

#### (dd) ESC M

[Name] **Write the value (dd) in the print mode**

[Format]	ASCII	dH	dL	ESC	M
	Hex	dH	dL	1B	4D
	Decimal	dH	dL	27	77

[Description] Sets the default parameters in the print mode:  
\$00 small character printing  
\$01 double width printing  
\$02 double height printing  
\$03 expanded printing

[Notes] • The setting is stored in the EEPROM

[Default] Setting through the front keys

[Reference] **ESC m**

[Example] To print in double height mode, transmit:  
\$30 \$32 \$1B \$4D

#### ESC p

[Name]	<b>Transmit the configuration register in serial</b>		
[Format]	ASCII	ESC	p
	Hex	1B	70
	Decimal	27	112
[Description]	Transmits the option register byte on the serial port		
[Notes]	• If the parallel protocol is in use, nothing will be transmitted		
[Default]			
[Reference]	<b>ESC G</b>		
[Example]	The response is on two bytes. For example, if you receive: \$30 \$39 it means that the default configuration is 00001001		

#### ESC m

[Name]	<b>Transmit the print mode in serial</b>		
[Format]	ASCII	ESC	m
	Hex	1B	6D
	Decimal	27	109
[Description]	Transmits the print mode configuration on the serial port		
[Notes]	• If the parallel protocol is in use, nothing will be transmitted		
[Default]	Setting in the option register using the front keys		
[Reference]	<b>ESC B</b>		
[Example]	The response is on two bytes. For example, if you receive: \$30, \$32 it means that double height printing is enabled		

#### ESC s

[Name]	<b>Transmit the next character in serial</b>		
[Format]	ASCII	ESC	s
	Hex	1B	73
	Decimal	27	115
[Description]	Transmits the next character received on the serial port		

### 3. PRINTER FUNCTIONS

[Notes]

[Default]

[Reference]

[Example] If you transmit: ESC s A  
the last character, A, is not printed, but immediately transmitted on the serial line

#### **(dd) ESC a**

[Name] **Select the number of dot spaces**

[Format] ASCII (dd) ESC a  
Hex (dd) 1B 61  
Decimal (dd) 27 97

[Description] (dd) are two ASCII characters that identify a hexadecimal byte and correspond to the number of dot lines between one line of print and another

[Notes]

[Default] = 0

[Reference]

[Example]

#### **ESC J (n) 10\*(d)**

[Name] **Load the programmable character**

[Format] ASCII ESC J (n)  
Hex 1B 4A (n)  
Decimal 27 74 (n)

[Description] (n) corresponds to the number of characters which can vary from 1 to 8.  
The bit map representing the character is contained in the 10 bytes that follow, expressed in binary code. The formatting of these bytes is as follows:

bit	7	6	5	4	3	2	1	0
	0	1	d	d	d	d	d	d

[Notes]

[Default] The 8 characters present when the printer is switched on are loaded with a bit map contained in the printer flash. Any user who wishes to modify these bit maps must upgrade the firmware.

### 3. PRINTER FUNCTIONS

[Reference]

[Example]

If you wish the symbol of the code \$1F to be #, transmit ESC  
J 2 followed by the 10 bytes making up the character:

\$1B \$4A \$32 \$52 \$52 \$52 \$7F \$52 \$52 \$7F \$52 \$52 \$52

### 3. PRINTER FUNCTIONS

#### 3.2.2ESC/POS emulation

(Tab.3.2)

TABLE OF COMMANDS

ASCII Comm,	HEX Comm.	Description
HT	\$09	Horizontal tabs
LF	\$0A	Print and feed forward
CR	\$0D	Print and feed forward
DLE EOT n	\$10 \$04 (n)	Transmission of status in real time
ESC SP n	\$1B \$20 (n)	Set space to right of character
ESC ! n	\$1B \$21 (n)	Set print mode
ESC * m nL nH d1...dk	\$1B \$2A m nL nH d1...dk	Set graphic print mode
ESC - n	\$1B \$2D (n)	Enable/disable underlined printing
ESC 2	\$1B \$32	Select line spacing at 1/6 inch
ESC 3 n	\$1B \$33 (n)	Set spacing using minimum units
ESC = n	\$1B \$3D (n)	Select device
ESC @	\$1B \$40	Initialize the printer
ESC D n1...nk NUL	\$1B \$44 n1...nk 00	Set horizontal tab positions
ESC E n	\$1B \$45 (n)	Select expanded printing
ESC J n	\$1B \$4A (n)	Print and forward feed paper
ESC K n	\$1B \$4B (n)	Print and backward feed paper
ESC R n	\$1B \$52 (n)	Select international character set
ESC a n	\$1B \$61 (n)	Select justification
ESC c 5 n	\$1B \$63 \$35 (n)	Enable/disable front panel keys
ESC d n	\$1B \$64 (n)	Print and forward feed paper by n lines
ESC e n	\$1B \$65 (n)	Print and backward feed paper by n lines
ESC t n	\$1B \$74 (n)	Select character code table
ESC { n	\$1B \$7B (n)	Set/cancel upside down character printing
GS I n	\$1D \$49 (n)	Transmit printer ID
GS V m n	\$1D \$56	Forward feed paper to cutting position
GS r n	\$1D \$72 (n)	Transmit status

### 3. PRINTER FUNCTIONS

The following pages provide a more detailed description of each command.

#### HT

[[Name]	<b>Horizontal tabs</b>
[Format]	ASCII    HT Hex       09 Decimal   9
[Description]	Shifts the print position to the next horizontal tab.
[Notes]	<ul style="list-style-type: none"><li>• This command is ignored if the next horizontal tab has not been set.</li><li>• If the next horizontal tab is outside the print area, the printer will print the entire contents of the print buffer, then proceed with the processing of the horizontal tabs from the beginning of the following line.</li><li>• The horizontal tabs are set through the command ESC D.</li></ul>
[Default]	<ul style="list-style-type: none"><li>• By default, the next tab positions are at intervals of 8 characters (columns 9, 17, 25..) .</li></ul>
[Reference]	<b>ESC D</b>
[Example]	

#### LF

[Name]	<b>Print and forward feed</b>
[Format]	ASCII    LF Hex       0A Decimal   10
[Description]	Prints the data in the buffer and forward feeds by one line, according to the currently set line spacing.
[Notes]	<ul style="list-style-type: none"><li>• This command sets the print position at the beginning of the line.</li></ul>
[Default]	
[Reference]	<b>ESC 2, ESC 3</b>
[Example]	

### 3. PRINTER FUNCTIONS

#### CR

[Name]	<b>Print and forward feed</b>
[Format]	ASCII    CR Hex        0D Decimal    13
[Description]	This command prints the data in the buffer.
[Notes]	• This command sets the print position at the beginning of the line.
[Default]	
[Reference]	<b>LF</b>
[Example]	

#### DLE EOT n

[Name]	<b>Transmission of status in real time</b>
[Format]	ASCII    DLE   EOT   n Hex        10    04    n Decimal    16    4     n
[Interval]	$1 \leq n \leq 4$
[Description]	Transmits in real time the selected status of the printer specified by n according to the following parameters: n = 1    transmit printer status n = 2    transmit off-line status n = 3    transmit error status n = 4    transmit paper roll sensor status
[Notes]	• This command is carried out even when the reception buffer is full. • While the status is being transmitted, the printer supplies 1 byte only without acknowledging the condition of the DSR signal. • This command is carried out even when the printer is off-line, the reception buffer is full or there is an error in course. • This status is transmitted each time the following sequence of data 10H 04H n ( $1 \leq n \leq 4$ ) is received. For example: in <b>ESC * m nL nH [d] nL+256nH</b> , d1=10H, d2=04H, d3=1H • This command cannot be used within the data sequence of another command consisting of 2 or more bytes.
[Default]	
[Reference]	



### 3. PRINTER FUNCTIONS

[Example]

n=1: Printer status

Bit	Off/On	Hex	Decimal	Function
0	Off	00	0	Not used. Set at Off.
1	On	02	2	Not used. Set at On.
2	Off	00	0	Low drawer extraction signal.
	On	04	4	High drawer extraction signal.
3	Off	00	0	On-line.
	On	08	8	Off-line.
4	On	10	16	Not used. Set at On
5	Off	00	0	Not used. Set at Off
6	-	-	-	Not defined.
7	Off	00	0	Not used. Set at Off

n=2: Off-line status

Bit	Off/On	Hex	Decimal	Function
0	Off	00	0	Not used. Set at Off.
1	On	02	2	Not used. Set at On.
2	Off	00	0	No error
	On	04	4	Error
3	On	08	8	Not used. Set at On.
4	On	10	16	Not used. Set at On
5	Off	00	0	Not used. Set at Off.
6	Off	00	0	No error
	On	40	64	Error
7	Off	00	0	Not used. Set at Off

n=3: Error status

Bit	Off/On	Hex	Decimal	Function
0	Off	00	0	Not used. Set at Off.
1	On	02	2	Not used. Set at On.
2	Off	00	0	No print mechanism error
	On	04	4	Print mechanism error.
3	-	-	-	Not defined.
4	On	10	16	Not used. Set at On
5	Off	00	0	Irrecouperable error.
	On	20	32	Recouperable error.
6	Off	00	0	No print mechanism error.
	On	40	64	Print mechanism error
7	Off	00	0	Not used. Set at Off

### 3. PRINTER FUNCTIONS

n=4: Paper roll sensor

Bit	Off/On	Hex	Decimal	Function
0	Off	00	0	Not used. Set at Off.
1	On	02	2	Not used. Set at On.
2	Off	00	0	Not used. Set at Off.
3	Off	00	0	Not used. Set at Off.
4	On	10	16	Not used. Set at On
5	Off	00	0	Not used. Set at Off.
6	Off	00	0	Not used. Set at Off.
7	Off	00	0	Not used. Set at Off

#### ESC SP n

[Name]	<b>Set the spacing to the right of the character</b>
[Format]	ASCII    ESC SP    n Hex        1B    20    n Decimal    27    32    n
[Interval]	0 ≤ n ≤ 255
[Description]	Sets the spacing to the right of the character at [n x (1/160)]inches
[Notes]	• The spacing to the right of the character for double width mode is double that used for normal mode.
[Default]	n = 0
[Reference]	
[Example]	

#### ESC ! n

[Name]	<b>Select print mode.</b>
[Format]	ASCII    ESC !    n Hex        1B    21    n Decimal    27    33    n
[Interval]	0 ≤ n ≤ 255

### 3. PRINTER FUNCTIONS

[Description] Selects the print modes using *n* as in the following table:

Bit	Off/On	Hex	Decimal	Function
0	Off	00	0	9x9 character font selected.
	On	01	1	7x9 character font selected.
1	-	-	-	Not defined.
2	-	-	-	Not defined.
3	Off	00	0	Expanded mode not selected.
	On	08	8	Expanded mode selected.
4	Off	00	0	Double height mode not selected.
	On	10	16	Double height mode selected.
5	Off	00	0	Double width mode not selected.
	On	20	32	Double width mode selected.
6	-	-	-	Not defined.
7	Off	00	0	Underlined mode not selected.
	On	80	128	Underlined mode selected.

[Notes]

- When double height and double width print modes are selected, the characters four times normal size are printed.
- Each character is underlined for the entire width, including the space to the right of the character but not the space set by the command HT.

[Default] *n* = 0

[Reference] **ESC -, ESC E**

[Example]

#### ESC \* m nL nH d1...dk

[Name] **Select dot image mode.**

[Format]

ASCII	ESC	*	<i>m</i>	<i>nL</i>	<i>nH</i>	<i>d1...dk</i>
Hex	1B	2A	<i>m</i>	<i>nL</i>	<i>nH</i>	<i>d1...dk</i>
Decimal	27	42	<i>m</i>	<i>nL</i>	<i>nH</i>	<i>d1...dk</i>

[Interval]

*m* = 0, 1

$0 \leq nL \leq 255$

$0 \leq nH \leq 1$

$0 \leq d \leq 255$

### 3. PRINTER FUNCTIONS

[Description] Selects dot image mode using m to represent the number of dots specified by nL and nH.

- nL and nH indicate the number of dots in the image, in horizontal dots. For the total number of dots, calculate  $nL + nH * 256$ .
- If the piece of data entered for the graphic bit is greater than the number of dots to be printed on a line, the extra data will be ignored.
- d indicates the dot image data. If you wish to print the dot, set a bit corresponding to 1 and if you do not wish to print the dot, set a bit corresponding to 0.
- dot image mode is selected using m as follows:

m	N° of vertical points	Density of points	Horizontal direction	
			Adjacent point	Max. n° of points
0	8	Single density	Authorized	72 DP24
				120 DP40
1	8	Double density	Not authorized	144 DP24
				240 DP40

[Notes]

- After printing a dot image, the printer returns to its normal mode of processing data.
- The relationship between the image data and the dots to be printed is the following:

8 dot image

24 dot image

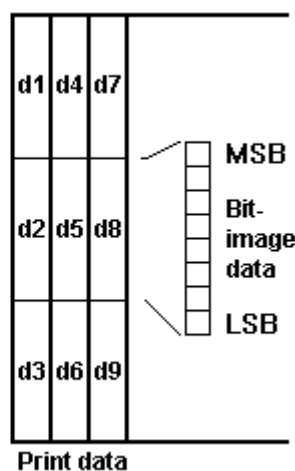
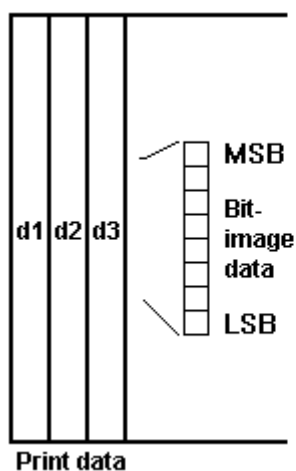

[Default]

[Reference]  
[Example]

#### ESC - n

[Name] **Enable / disable underlined printing.**

[Format] ASCII ESC - n  
Hex 1B 2D n  
Decimal 27 45 n

[Interval] n = 0, 1, 48, 49

[Description] Enables or disables underlined printing, and is based on the following values of n:  
n = 0, 48 Disable underlined printing  
n = 1, 49 Enable underlined printing

[Notes] 

- The printer can underline all the characters but it cannot underline the space set by the command HT.
- Underlined printing can also be enabled or disabled using the command ESC !. Please note, however, that the last command received is enabled

[Default] n=0

[Reference] **ESC !**

[Example]

#### ESC 2

[Name] **Set line spacing at 1/6 inch.**

[Format] ASCII ESC 2  
Hex 1B 32  
Decimal 27 50

[Description] Selects 1/6 inch line spacing.

[Notes]

[Default]

[Reference] **ESC 3**

[Example]

### 3. PRINTER FUNCTIONS

#### ESC 3 n

[Name]	<b>Set line spacing.</b>
[Format]	ASCII    ESC 3    n Hex        1B    33    n Decimal    27    51    n
[Interval]	$0 \leq n \leq 255$
[Description]	Sets line spacing at $[n \times (1/144)]$ inches.
[Notes]	
[Default]	$n = 24$ (1/6 inch)
[Reference]	<b>ESC 2</b>
[Example]	

#### ESC = n

[[Name]	<b>Select the peripheral device</b>
[Format]	ASCII    ESC =    n Hex        1B    3D    n Decimal    27    61    n
[Interval]	1 £ n £ 3
[Description]	Selects the device to which the host computer sends the data, using n as follows:

Bit	Off/On	Hex	Decimal	Function
0	Off	00	0	Printer disabled.
	On	01	1	Printer enabled.
1	Off	00	0	Customer display disabled.
	On	02	2	Customer display enabled.
2	-	-	-	Not defined
3	-	-	-	Not defined
4	-	-	-	Not defined
5	-	-	-	Not defined
6	-	-	-	Not defined
7	-	-	-	Not defined

[Notes]	<ul style="list-style-type: none"><li>• When the printer is disabled, it ignores all the data transmitted until this command re-enables the printer.</li></ul>
---------	--

[Default] n = 1

[Reference]

[Example]

#### ESC @

[Name] **Initalize the printer.**

[Format] ASCII ESC @  
Hex 1B 40  
Decimal 27 64

[Description] Erases all the data in the print buffer and resets the printer mode to the one enabled when the printer was switched on

[Notes] 

- The data in the reception buffer are not erased.
- The settings of the DIP switches are not re-checked.

[Default]

[Reference]

[Example]

#### ESC D n1...nk NUL

[Name] **Set the horizontal tabs.**

[Format] ASCII ESC D n1...nk NUL  
Hex 1B 44 n1...nk 00  
Decimal 27 68 n1...nk 0

[Interval]  $1 \leq n \leq 255$   
 $0 \leq k \leq 32$

[Description] Sets the horizontal tabs.

- n specifies the number of columns for setting a horizontal tab from the beginning of the line.
- k indicates the total number of horizontal tabs to be set.

[Notes] 

- The horizontal tab is stored as a value of [character width x n] measured from the beginning of the line. The width of the character includes the space to the right of the character and double width characters are set with a width which is double that of normal characters.

### 3. PRINTER FUNCTIONS

- This command annuls the previous tab setting.
- When the setting is  $n = 8$ , the print position shifts to column 9 transmitting HT.
- Up to 32 tabs can be set ( $k = 32$ ). Any data exceeding the 32 tabs is processed as normal data.
- Transmit  $[n]k$  in ascending order and put a code 0 NUL at the end. When  $[n]k$  is less than or equal to the previous value  $[n]k-1$ , the tab setting process is finished and any data that follows is processed as normal data.
- ESC D NUL annuls all the horizontal tabs.
- The previously specified horizontal tab does not change, even if the width of the character does.

[Default] The default tabs are at intervals of 8 characters (columns 9, 17, 25, ...) for the 7x9 Font when the space to the right of the character is 0.

[Reference] **HT**

[Example]

#### ESC E n

[Name] **Enable/disable expanded mode.**

[Format] ASCII    ESC E    n  
Hex        1B 45    n  
Decimal    27 69    n

[Interval]  $0 \leq n \leq 255$

[Description] Enables or disables expanded mode.

- When the LSB of  $n$  is 0, expanded mode is disabled.
- When the LSB of  $n$  is 1, expanded mode is enabled.

[Notes] 

- Only the LSB of  $n$  is enabled.
- The command ESC ! also enables or disables expanded mode. In any case, the last command received is enabled.

[Default]  $n = 0$

[Reference] **ESC !**

[Example]



#### ESC J n

[Name]	<b>Print and forward feed the paper.</b>
[Format]	ASCII    ESCJ    n Hex        1B 4A    n Decimal    27 74    n
[Interval]	$0 \leq n \leq 255$
[Description]	Prints the data in the print buffer and forward feed the paper by [ n x (1/144)] inches.
[Notes]	<ul style="list-style-type: none"><li>• After finishing printing, this command sets the position at which printing starts at the beginning of the line.</li><li>• The amount of paper which forward feeds as a result of this command does not change the values set by the commands ESC 2or ESC 3.</li></ul>
[Default]	
[Reference]	<b>ESC K</b>
[Example]	

#### ESC K n

[Name]	<b>Print and backward feed the paper.</b>
[Format]	ASCII    ESCK    n Hex        1B 4B    n Decimal    27 75    n
[Interval]	$0 \leq n \leq 48$
[Description]	Prints the data in the print buffer and backward feeds the paper by [ n x (1/144)] inches.
[Notes]	<ul style="list-style-type: none"><li>• This command does not need to be given more than twice.</li><li>• If n is outside the specified interval, the printer will print the data in the buffer and not forward feed the paper.</li><li>• Backward feeding of the paper leads to the following problems:<ol style="list-style-type: none"><li>1) Imprecise paper forward feeding pitch</li><li>2) More printer noise than usual</li><li>3) The paper could get dirty from rubbing against the ink cartridge ribbon</li></ol></li></ul>
[Default]	
[Reference]	<b>ESC J</b>
[Example]	

### 3. PRINTER FUNCTIONS

#### ESC R n

[Name]	<b>Select the international character set.</b>		
[Format]	ASCII	ESCR	n
	Hex	1B 52	n
	Decimal	27 82	n
[Interval]	$0 \leq n \leq 10$		
[Description]	Selects the international character set by setting n as in the following table :		
	n	Selected character	
	0	U.S.A.	
	1	France	
	2	Germany	
	3	U.K.	
	4	Denmark I	
	5	Sweden	
	6	Italy	
	7	Spain	
	8	Japan	
	9	Norway	
	10	Denmark II	
[Default]	n = 0		
[Reference]			
[Example]			

#### ESC a n

[Name]	<b>Select type of justification.</b>		
[Format]	ASCII	ESCa	n
	Hex	1B 61	n
	Decimal	27 97	n
[Interval]	$0 \leq n \leq 2, 48 \leq n \leq 50$		
[Description]	Align all the data on a line in the position specified. n selects the type of justification as follows:		
	<b>n</b>	<b>Justification</b>	
	0, 48	Align to the left	
	1, 49	Centring	
	2, 50	Align to the right	

### 3. PRINTER FUNCTIONS

[Notes] • This command is only enabled when entered at the beginning of the line.

[Default] n = 0

[Reference]

[Example] Alignment to the left      Centring      Alignment to the right

ABC
ABCD
ABCDE

ABC
ABCD
ABCDE

ABC
ABCD
ABCDE

#### ESC c 5 n

[Name] **Enable or disable the front panel keys.**

[Format] ASCII      ESCc    5    n

Hex          1B   63   35   n

Decimal    27   99   53   n

[Interval]  $0 \leq n \leq 255$

[Description] Enables or disables the front panel keys.

- When the LSB of n is 0, the keys of the panel are enabled.
- When the LSB of n is 1, the keys of the pane are disabled.

[Notes] • Only the LSB of n is enabled.  
• When the panel keys are disabled, the printer is only available for use when reset.

[Default] n = 0

[Reference]

[Example]

#### ESC d n

[Name] **Print and forward feed the paper by n lines.**

[Format] ASCII      ESCd    n

Hex          1B   64   n

Decimal    27   100 n

[Interval]  $0 \leq n \leq 255$

[Description] Prints the data in the print buffer and forward feeds the paper by n lines.

[Notes] • This command sets the position at which printing starts at the beginning of the line.  
• The paper can forward feed by a maximum of 40 inches. Even if a forward feed command exceeding 40 inches is set,

### 3. PRINTER FUNCTIONS

the printer only forward feeds the paper by 40 inches.

[Default]

[Reference] **ESC e**

[Example]

#### **ESC e n**

[Name] **Print and backward feed the paper by n lines.**

[Format] ASCII ESCe n  
Hex 1B 65 n  
Decimal 27 101 n

[Interval]  $0 \leq n \leq 255$

[Description] Prints the data in the print buffer and backward feeds the paper by n lines.

[Notes]

- This command does not need to be given more than twice.
- If n is outside the specified interval, if the total forward feed of the paper exceeds 48/144 inches, the printer will print the data in the buffer and not forward feed the paper.
- Backward feeding of the paper leads to the following problems:
  - 1) Imprecise paper forward feeding pitch
  - 2) More printer noise than usual
  - 3) The paper could get dirty from rubbing against the ink cartridge ribbon

[Default]

[Reference] **ESC d**

[Example]

#### **ESC t n**

[Name] **Select the character code table.**

[Format] ASCII ESCt n  
Hex 1B 74 n  
Decimal 27 116 n

[Interval]  $0 \leq n \leq 5, n = 254, 255$

[Description] Select a page n from the character code table, as follows:

### 3. PRINTER FUNCTIONS

n	Page	Character type
0	0	(PC437[U.S.A., Standard Europe=])
1	1	(Katakana)
2	2	(PC850 [Multilingual])
3	3	(PC860 [Portuguese])
4	4	(PC850 [Canadian - French])
5	5	(PC850 [Northern Countries])
254	Page space	
255	Page space	

[Notes]

[Default] n = 0

[Reference]

[Example]

#### ESC { n

[Name] **Enable or disable upside down characters.**

[Format] ASCII ESC{ n  
Hex 1B 7B n  
Decimal 27 123 n

[Interval]  $0 \leq n \leq 255$

[Description] Enables or disables upside down printing.

- When the LSB of n is 0, upside down printing is disabled..
- When the LSB of n is 1, upside down printing is enabled.

[Notes]

- Only the LSB of n is enabled.
- This command is only enabled if entered at the beginning of a line.
- In upside down printing mode, the printer rotates the line to be printed by 180° and then prints it.

[Default] n = 0

[Reference]

[Example]

### 3. PRINTER FUNCTIONS

Upside down printing Off      Upside down printing On

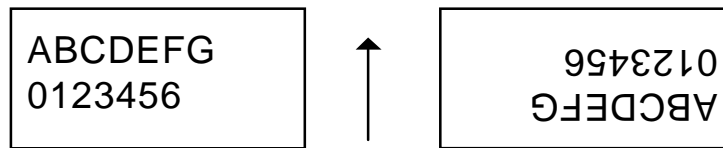

Towards paper outfeed

#### GS In

[Name]            **Transmit printer ID.**

[Format]        ASCII      GS I    n  
                   Hex        1D 49 n  
                   Decimal 29 73 n

[Interval]       0 ≤ n ≤ 3, 49 ≤ n ≤ 51

[Description]    Transmits the printer ID specified by n as follows:

n	Printer ID	Specification	ID (Hex.)
1, 49	Printer model identification	FH190SP	0D
2, 50	Function identification	See table below	
3, 51	ROM version identification	Depends on ROM version	

#### n = 2, Function identification

Bit	Off/On	Hex	Decimal	Function
0	Off	00	0	Unsupported 2 byte character codes
1	Off	00	0	Autocutter not supplied
2	-	-	-	Not defined
3	-	-	-	Not defined
4	Off	00	0	Not used. Set at Off
5	-	-	-	Not defined
6	-	-	-	Not defined
7	Off	00	0	Not used. Set at Off

[Notes]

- When the DTR/DSR control is selected, the printer only transmits 1 byte (Printer identification) after it has been given confirmation that the host is ready to receive data. If the host is not ready, the printer waits until it is.
- When the XON/XOFF control is selected, the printer only transmits 1 byte (Printer identification) if it has not been given confirmation that the host is ready to receive data.

### 3. PRINTER FUNCTIONS

- This command is carried out once the data has been processed in the reception buffer. There may therefore be a delay between the moment in which the command is received and that in which the data is transmitted, depending on the status of the reception buffer.

[Default]

[Reference]

[Example]

#### **GS V m n**

[Name] **Forward feed the paper to the cutting position.**

[Format] ASCII GS V m n  
Hex 1D 56 m n  
Decimal 29 86 m n

[Interval]  $65 \leq m \leq 66, 0 \leq n \leq 255$

[Description] Forward feeds the paper to the cutting position as follows:

**m Print mode**

65 Forward feed paper by (cutting position + [n x (1/144 inches)])

66 Forward feed paper by (cutting position + [n x (1/144 inches)])

[Notes]

- This command only works at the beginning of a line.
- By cutting position is meant the position for manual cutting.

[Default]

[Reference]

[Example]

#### **GS r n**

[Name] **Transmit status.**

[Format] ASCII GS r n  
Hex 1D 72 n  
Decimal 29 114 n

[Interval]  $1 \leq n \leq 2, 49 \leq n \leq 50$

[Description] Transmits the status specified by n as follows:

**n Function**

1. 49 Transmit paper sensor status

2. 50 Transmit cash drawer connector status

### 3. PRINTER FUNCTIONS

[Notes]

- When the DTR/DSR control is selected, the printer only transmits 1 byte (Printer identification) after it has been given confirmation that the host is ready to receive data. If the host is not ready, the printer waits until it is.
- When the XON/XOFF control is selected, the printer only transmits 1 byte (Printer identification) if it has not been given confirmation that the host is ready to receive data.
- This command is carried out once the data has been processed in the reception buffer. There may therefore be a delay between the moment in which the command is received and that in which the data is transmitted, depending on the status of the reception buffer.
- The types of status transmitted can be seen below:

#### Paper sensor status (n = 1, 49)

Bit	Off/On	Hex	Decimal	Function
0,1	Off	00	0	Reserve paper sensor: paper present
	On	(03)	(3)	Reserve paper sensor: paper almost out
2,3	Off	00	0	Paper out sensor: paper present
	On	0C	12	Paper out sensor: paper not present
4	Off	00	0	Not used. Set at Off
5	-	-	-	Not defined
6	-	-	-	Not defined
7	Off	00	0	Not used. Set at Off

Bits 0 and 1: The reserve paper sensor is optional;

#### Drawer connector status (n = 2, 50)

Bit	Off/On	Hex	Decimal	Function
0	Off	00	0	Pin 3 Drawer connector at low level
	On	01	1	Pin 3 Drawer connector at high level
1	-	-	-	Not defined
2	-	-	-	Not defined
3	-	-	-	Not defined
4	Off	00	0	Not used. Set at Off
5	-	-	-	Not defined
6	-	-	-	Not defined
7	Off	00	0	Not used. Set at Off

[Default]

[Reference]

[Example]



### 3. PRINTER FUNCTIONS

#### 3.2.3 CITIZEN emulation

TABLE OF COMMANDS

<b>ASCII Comm.</b>	<b>HEX Comm.</b>	<b>Description</b>
LF	\$0A	Print and forward feed
CR	\$0D	Print and forward feel
FF	\$0A	Forward feed paper after printing
RS	\$1E	Improved character designation (one line)
(US	\$1F	Standard character designation
SI	\$0F	Standard character designation (same as US)
SO	\$0E	Improved character designation (same as RS)
DC1	\$11	Place printer ON LINE
DC3	\$13	Place printer OFF LINE
DC4	\$14	Set / cancel reverse print mode
ESC 1	\$1B \$31	3 mm line spacing
ESC 2	\$1B \$32	5.5 mm line spacing
ESC C n	\$1B \$43 (n)	Page length and format designation
ESC K n1 n2	\$1B \$4B (n1 n2)	Graphic print mode
ESC O	\$1B \$4F	Formatting off

### 3. PRINTER FUNCTIONS

The following pages provide a more detailed description of each command.

#### LF

[[Name]	<b>Print and forward feed</b>
[Format]	ASCII    LF Hex        0A Decimal    10
[Description]	Prints the data in the buffer and forward feeds by one line, according to the currently set line spacing.
[Notes]	This command sets the print position at the beginning of the line.
[Default]	
[Reference]	<b>ESC 1, ESC 2</b>
[Example]	

#### CR

[Name]	<b>Print and forward feed</b>
[Format]	ASCII    CR Hex        0D Decimal    13
[Description]	When automatic forward feed is “enabled CR”, this command works in exactly the same way as LF, otherwise, it is ignored.
[Notes]	This command sets the print position at the beginning of the line.
[Default]	
[Reference]	<b>LF</b>
[Example]	

#### FF

[Name]	<b>Forward feed the paper after printing.</b>
[Format]	ASCII    FF Hex        0A Decimal    10
[Description]	Prints the data in the buffer and forward feeds the paper on the basis of the length of the page specified by the command ESC C n.

### 3. PRINTER FUNCTIONS

[Notes] This command sets the print position at the beginning of the line.

[Default]

[Reference] **ESC C**

[Example]

#### **RS**

[Name] **Improved character designation.**

[Format] ASCII RS  
Hex 1E  
Decimal 30

[Description] The printer prints in expanded character mode

[Notes] The command RS is automatically launched after printing.

[Default] Setting through the front keys.

[Reference] **US, SI, SO, 01H, 02H, 03H, 04H**

[Example]

#### **US**

[Name] **Standard character designation.**

[Format] ASCII US  
Hex 1F  
Decimal 31

[Description] The printer prints in small (normal) character mode

[Notes]

[Default] Setting through the front keys

[Reference] **RS, SI, SO, 01H, 02H, 03H, 04H**

[Example]

#### **SI**

[Name] **Standard character designation (same as US)**

[Format] ASCII SI  
Hex 0F  
Decimal 15

### 3. PRINTER FUNCTIONS

[Description] The printer prints in small (normal) character mode  
[Notes] Same as US  
[Default] Setting through the front keys  
[Reference] **RS, US, SO, 01H, 02H, 03H, 04H**  
[Example]

#### SO

[Name] **Improved character designation (same as RS)**  
[Format] ASCII SO  
Hex 0E  
Decimal 14  
[Description] The printer prints in expanded character mode  
[Notes] The command SO is automatically launched after printing.  
Same as RS  
[Default] Setting through the front keys  
[Reference] **RS, US, SI, 01H, 02H, 03H, 04H**  
[Example]

#### DC1

[Name] **Place the printer ON LINE.**  
[Format] ASCII DC1  
Hex 11  
Decimal 17  
[Description] Places the printer ON LINE.  
[Notes] Only this code can be accepted independently of the status  
OFF LINE.  
[Default]  
[Reference] **DC3**  
[Example]

#### DC3

[Name]	<b>Place the printer OFF LINE.</b>	
[Format]	ASCII	DC3
	Hex	13
	Decimal	19
[Description]	Places the printer OFF LINE.	
[Notes]		
[Default]		
[Reference]	<b>DC1</b>	
[Example]		

#### DC4

[Name]	<b>Set/ cancel reverse printing mode.</b>	
[Format]	ASCII	DC4
	Hex	14
	Decimal	20
[Description]	Sets / erases (alternately) reverse printing mode.	
[Notes]		
[Default]		
[Reference]		
[Example]		

#### ESC 1

[Name]	<b>Set 3 mm. line spacing</b>		
[Format]	ASCII	ESC	1
	Hex	1B	31
	Decimal	27	49
[Description]	Sets 3 mm line spacing		
[Notes]			
[Default]			
[Reference]	<b>ESC 2</b>		
[Example]			

#### ESC 2

[Name] **Set 5.5 mm line spacing.**

[Format] ASCII ESC 2  
Hex 1B 32  
Decimal 27 50

[Description] Set 5.5 mm line spacing.

[Notes]

[Default]

[Reference] **ESC 1**

[Example]

#### ESC C n

[Name] **Page length and page format designation.**

[Format] ASCII ESC C n  
Hex 1B 43 n  
Decimal 27 67 n

[Interval]  $14 \leq n \leq 120$

[Description] This command sets the length (number of lines) of the page, and starts up page formatting.  
A three-line space is left at the top and bottom of the page.

[Notes] Page formatting can be cleared through the command ESC O

[Default]  $n = 66$

[Reference] **FF, ESC O**

[Example]

#### ESC K n1 n2

[Name] **Graphic mode printing**

[Format] ASCII ESC K n1 n2  
Hex 1B 4B n1 n2  
Decimal 27 75 n1 n2

[Interval]  $1 \leq n1 \leq 240$ ;  $n2 = \text{mute data}$

[Description] This command prints  $n1$  bytes of data in graphic mode. The data bytes are arranged vertically starting from the left

margin, but only the first seven LSBs are significant.

[Notes] After the last data byte, the printer prints, forward feeds the paper (by 21 dots per line) and graphic mode printing is cleared.

[Default]

[Reference]

[Example]

#### **ESC O**

[Name] **Page formatting off**

[Format] ASCII    ESC    O  
Hex        1B 4F  
Decimal    27 79

[Description] Cancel page formatting mode

[Notes]

[Default]

[Reference] **ESC C**

[Example]

## 4. TECHNICAL SPECIFICATIONS

### 4.1 TECHNICAL SPECIFICATIONS

The main technical features of the two printer models (FH190 24 and 40 columns) are listed in table 4.1.

(Tab.4.1)

<b>Columns</b>	<b>24</b>	<b>40</b>
<b>Character (L x H mm)</b>		
Normal	1.7 x 2.6	1.1 x 2.6
Double height	1.7 x 5.2	1.1 x 5.2
Double width	3.4 x 2.6	2.2 x 2.6
Expanded	3.4 x 5.2	2.2 x 5.2
<b>Graphic dot</b>	0.33 x 0.37	0.2 x 0.37
<b>Dots per line</b>	144	240
<b>Print speed</b>		
Lines / sec	2.7 ± 20%	1.8 ± 20%
Characters / sec	67	67
FEED (lines / sec)	21.6 ± 20%	14.4 ± 20%
<b>Line buffer</b>	24 byte	40 byte
<b>Reception buffer</b>	1Kbyte	
<b>Print method</b>	Impact dot matrix	
<b>Character matrix</b>	6 x 10 dots	
<b>Print direction</b>	Normal or reverse	
<b>Character set</b>	Normal and extended	
<b>Paper roll dimensions</b>	57.5 ± 0.5 mm x Ø50 mm max	
<b>Standard interfaces</b>	RS232 serial or CENTRONICS	
<b>Power supply</b>	Double or single 5Vdc ± 10% Single 9 - 40 Vdc optional	
<b>Absorption (with 5 Volt power supply)</b>		
Stand-by	80 mA	
Medium when printing	2 A	
Impulsive when printing	6 Apk per 600 µsec.	
<b>Environmentals conditions</b>		
Operating temperature	0°C - 50°C	
Operating humidity	35% - 85%	
Storage temperature / humidity	-20°C - +70°C / 10% - 90%	
<b>Options</b>	Real time clock	



### 4.2 DIMENSIONS

The dimensions of the panel printer FH190SP are shown in table 4.1. With the screws fitted in the printer, the maximum thickness of the panel is 5 mm; using the two additional screws provided, the printer can be mounted on panels with a maximum thickness of 15 mm. For even thicker panels, use longer M3 screws.

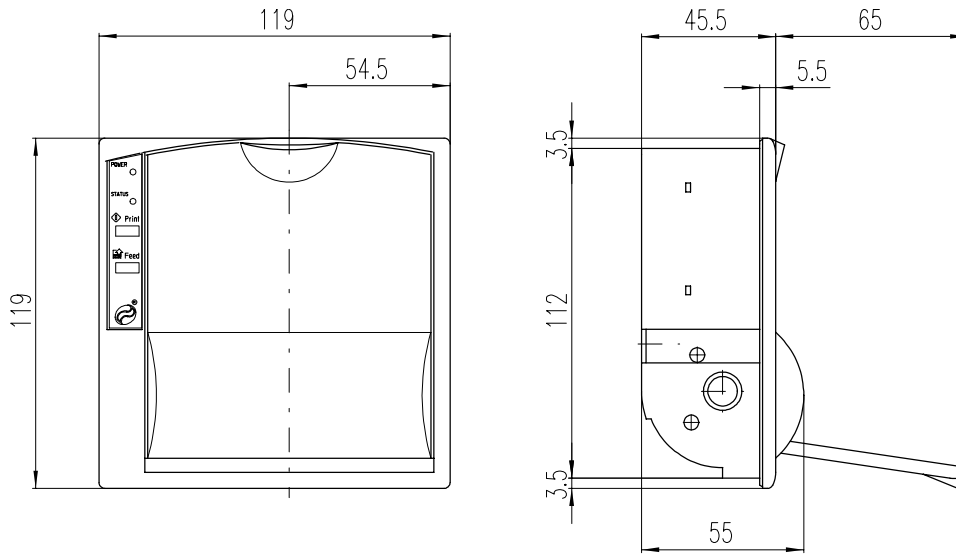

(Fig.4.1)

# 5. CHARACTER SETS

## 5.1 CHARACTER SETS

The FH190SP printer has two characters sets, each containing 224 characters (font 1 and font 2), which can be called up through the programming (paragraph 1.2) or through the control characters (paragraph 3.2).

	FONT 1
	123456789ABCDEF
0	0@PφPÇÉ á: L α≡
1	!1AQaαúæí L β±
2	"2BRbréáó L ΓΣ
3	#3CScsäöü L Πξ
4	\$4DTdtäöñ -L Σ↑
5	%5EUeuàðñ L ρσ↓
6	&6FUfúáQ& L μ÷
7	⌘'7Gwswçù& L τζ
8	⌘(8HXh×éÿç L ⊖°
9	⌘)9IYiyëö L ⊖·
A	⌘*:JZjzèü L ⊖λ
B	+;Klk °i#½ L ⊖δ↓
C	⌘<L\l±î&k L ⊖°ñ
D	⌘-M]mîî&i L ⊖θ²
E	⌘>N^n&ß«= L ⊖εΔ
F	⌘?O_ó#Áf» L ⊖π†

(Fig.5.1)

	FONT 2
	123456789ABCDEF
0	0@P' PAPA: L PQ
1	!1AQaαBCó L C±
2	"2BRbrBTB L TΣ
3	#3CScsΓΥΓ L Vξ
4	\$4DTdtΠΦπ -L βφ↓
5	%5EUeuEXe L ρκ↓
6	&6FUfúXUx L μ÷
7	⌘'7Gwsw&Yz L γζ
8	⌘(8HXh×MШM L ⊖°
9	⌘)9IYiy&ШЙ L ⊖·
A	⌘*:JZjzKbK L ⊖b·
B	+;Klk<ΠYπ L ⊖δ↓
C	⌘<L\lIMbM L ⊖bñ
D	⌘-M]m)H3H L ⊖ε²
E	⌘>N^n^O0o L ⊖°
F	⌘?O_óΔΠЯπ L ⊖π†

(Fig.5.2)

## A.1 ACCESSORIES

### A.1.1 Power supply

The following figure shows the power supply, manufactured by Custom Engineering, that can be used to operate the FH190SP printer.

The power supply is available in 3 different models:

- PSM05 for the version fed at 5V
- PSM12 and PSM24 for the version fed at 9 - 40 V

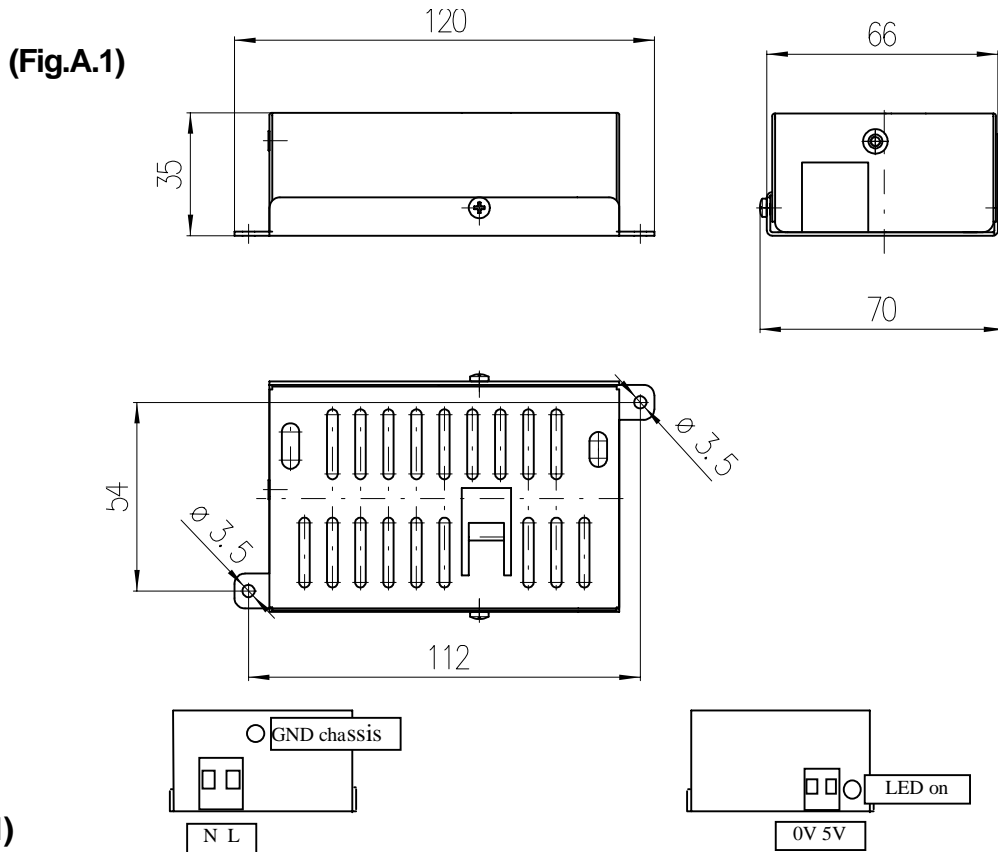

### Input specifications

Input voltage	100 Vac to 240 Vac
Input frequency	50 Hz to 60 Hz

### PSM05 Output specifications

Output voltage	5 V	
Output current	Minimum	0 A
	Maximum	3,6 A
	Peak	5 A(1)
	Short Circuit	6 A(2)

## PSM12 Output specifications (for option 9 - 40 Vdc)

Output voltage		12 V
Output current	Minimum	0 A
	Maximum	4 A
	Peak	6 A
	Short Circuit	6 A

## PSM24 Output specifications (for option 9 - 40 Vdc)

Output voltage		24 V
Output current	Minimum	0 A
	Maximum	2 A
	Peak	3,5 A
	Short Circuit	6 A

### A.1.2 Paper winder

(Fig.A.2)

The paper winder model AV03 can be connected to the FH190SP printer through connector J5.

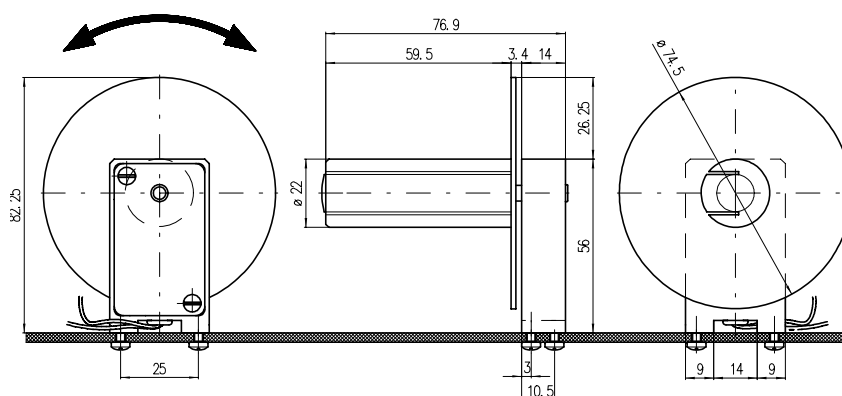

S

### Technical specifications:

Range of application	Universal
Paper width	60 mm
Roll diameter (max)	70 mm
Power supply	5 - 12Vdc $\pm$ 10%
Electrical input (max)	450 mA

(Tab.A.2)

**A.2 SPARE PARTS**

**(Tab.A.3)**

<b>RCN57X50</b>		<b>Normal paper roll</b>			
	Quantity recommended for number of appliances purchased				
N° appliances	<10	<50	<100	>100	
Quantity recommended	5	30	60	90	

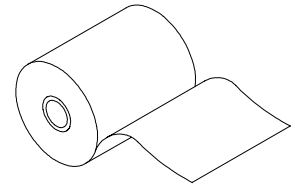

**(Fig.A.3)**

**(Tab.A.2)**

<b>ERC09 INK</b>		<b>Ink ribbon</b>			
	Quantity recommended for number of appliances purchased				
N° appliances	<10	<50	<100	>100	
Quantity recommended	5	30	60	90	

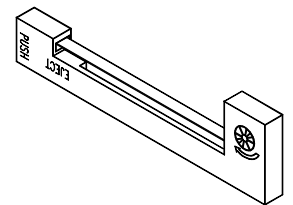

**(Fig.A.4)**