

COMMANDS MANUAL

TG1260HIII

TG2460HIII

TG2480HIII

TL60III

TL80III

CUSTOM[®]

CUSTOM S.p.A.
Via Berettine 2/B
43010 Fontevivo (PARMA) - Italy
Tel. : +39 0521-680111
Fax : +39 0521-610701
http: www.custom.biz

Customer Service Department:
www.custom4u.it

© 2019 CUSTOM S.p.A. – Italy.
All rights reserved. Total or partial reproduction of this manual in whatever form, whether by printed or electronic means, is forbidden. While guaranteeing that the information contained in it has been carefully checked, CUSTOM S.p.A. and other entities utilized in the realization of this manual bear no responsibility for how the manual is used. Information regarding any errors found in it or suggestions on how it could be improved are appreciated. Since products are subject to continuous check and improvement, CUSTOM S.p.A. reserves the right to make changes in information contained in this manual without prior notification.

The pre-installed multimedia contents are protected from Copyright CUSTOM S.p.A. Other company and product names mentioned herein may be trademarks of their respective companies. Mention of third-party products is for informational purposes only and constitutes neither an endorsement nor a recommendation. CUSTOM S.p.A. assumes no responsibility with regard to the performance or use of these products.

THE IMAGES USED IN THIS MANUAL ARE USED AS AN ILLUSTRATIVE EXAMPLES. THEY COULDN'T REPRODUCE THE DESCRIBED MODEL FAITHFULLY.

UNLESS OTHERWISE SPECIFIED, THE INFORMATION GIVEN IN THIS MANUAL ARE REFERRED TO ALL MODELS IN PRODUCTION AT THE ISSUE DATE OF THIS DOCUMENT.

GENERAL INSTRUCTIONS

CUSTOM S.p.A. declines all responsibility for accidents or damage to persons or property occurring as a result of tampering, structural or functional modifications, unsuitable or incorrect installations, environments not in keeping with the equipment's protection degree or with the required temperature and humidity conditions, failure to carry out maintenance and periodical inspections and poor repair work.

GENERAL SAFETY INFORMATION

Your attention is drawn to the following actions that could compromise the characteristics of the product:

- Read and retain the instructions which follow.
- Follow all indications and instructions given on the device.
- Make sure that the surface on which the device rests is stable. If it is not, the device could fall, seriously damaging it.
- Make sure that the device rests on a hard (non-padded) surface and that there is sufficient ventilation.
- Do not fix indissolubly the device or its accessories such as power supplies unless specifically provided in this manual.
- When positioning the device, make sure cables do not get damaged.
- [Only OEM equipment] The equipment must be installed in a kiosk or system that provides mechanical, electrical and fire protection.
- The mains power supply must comply with the rules in force in the Country where you intend to install the equipment.
- Make sure that there is an easily-accessible outlet with a capacity of no less than 10A closely to where the device is to be installed.
- Make sure the power cable provided with the appliance, or that you intend to use is suitable with the wall socket available in the system.
- Make sure the electrical system that supplies power to the device is equipped with a ground wire and is protected by a differential switch.
- Before any type of work is done on the machine, disconnect the power supply.
- Use the type of electrical power supply indicated on the device label.
- These devices are intended to be powered by a separately certified power module having an SELV, non-energy hazardous output. (IEC60950-1 second edition).
- [Only POS equipment] The energy to the equipment must be provided by power supply approved by CUSTOM S.p.A.
- Take care the operating temperature range of equipment and its ancillary components.
- Do not block the ventilation openings.
- Do not insert objects inside the device as this could cause short-circuiting or damage components that could jeopardize printer functioning.
- Do not carry out repairs on the device yourself, except for the normal maintenance operations given in the user manual.
- The equipment must be accessible on these components only to trained, authorized personnel.
- Periodically perform scheduled maintenance on the device to avoid dirt build-up that could compromise the correct, safe operation of the unit.
- Do not touch the head heating line with bare hands or metal objects. Do not perform any operation inside the printer immediately after printing because the head and motor tend to become very hot.
- Use consumables approved by CUSTOM S.p.A.



THE CE MARK AFFIXED TO THE PRODUCT CERTIFY THAT THE PRODUCT SATISFIES THE BASIC SAFETY REQUIREMENTS.

The device is in conformity with the essential Electromagnetic Compatibility and Electric Safety requirements laid down in Directives 2014/30/EU and 2014/35/EU inasmuch as it was designed in conformity with the provisions laid down in the following Standards:

- EN 55032 (*Limits and methods of measurements of radio disturbance characteristics of Information Technology Equipment*)
- EN 55024 (*Information Technology Equipment – Immunity characteristics – Limits and methods of measurement*)
- EN 60950-1 (*Safety of information equipment including electrical business equipment*)

The device is in conformity with the essential requirements laid down in Directives 2014/53/EU about devices equipped with intentional radiators. The Declaration of Conformity and other available certifications can be downloaded from the site www.custom4u.it.



GUIDELINES FOR THE DISPOSAL OF THE PRODUCT

The crossed-out rubbish bin logo means that used electrical and electronic products shall NOT be mixed with unsorted municipal waste. For more detailed information about recycling of this product, refer to the instructions of your country for the disposal of these products.

- Do not dispose of this equipment as miscellaneous solid municipal waste, but arrange to have it collected separately.
- The re-use or correct recycling of the electronic and electrical equipment (EEE) is important in order to protect the environment and the wellbeing of humans.
- In accordance with European Directive WEEE 2002/96/EC, special collection points are available to which to deliver waste electrical and electronic equipment and the equipment can also be handed over to a distributor at the moment of purchasing a new equivalent type.
- The public administration and producers of electrical and electronic equipment are involved in facilitating the processes of the re-use and recovery of waste electrical and electronic equipment through the organisation of collection activities and the use of appropriate planning arrangements.
- Unauthorised disposal of waste electrical and electronic equipment is punishable by law with the appropriate penalties.



The format used for this manual improves use of natural resources reducing the quantity of necessary paper to print this copy.

INTRODUCTION



TGH EMULATION



CUSTOM/POS EMULATION



ALIGNMENT





INTRODUCTION

1	CONSULTING COMMANDS MANUAL	6
2	IDENTIFICATION OF THE MODELS	8
3	PAPER SPECIFICATION	9



1 CONSULTING COMMANDS MANUAL

Each command reported in this manual is described as shown in the following picture. In the first heading field is reported the hexadecimal command value and the ASCII command value. In the second heading field reported the command function. In the third heading field are listed the devices on which it is possible to use the command (for example, device AAAA).

[Link to index](#)

Command value

Command function

Devices that use the command

0x0D **<CR>**

Print and carriage return

Valid for	AAAA
	BBBB
	CCCC

[Format] Hex 0x0D
 ASCII CR

[Range]

[Description] When Autofeed is "CR enabled", this command function in the same way as 0x0A, otherwise it is disregarded.

[Notes]

This command sets the printing position to the beginning of the line.

AAAA
BBBB

- This command sets the printing position to the beginning of the line.

CCCC

- This command is immediately executed even when the data buffer is full.
- This status is transmitted whenever data sequence is received.

[Default]

[Reference] 0x0A

[Example]

Information valid for devices AAAA, BBBB, CCC

Information valid only for devices AAAA, BBBB

Information valid only for device CCCC



The fields shown in the scheme of the previous figure have the following meaning:

[Format]	hexadecimal and ASCII command value.
[Range]	Limits of the values the command and its variables can take.
[Description]	Description of command function.
[Notes]	Additional information about command use and settings.
[Default]	Default value of the command and its variables.
[Reference]	Pertaining commands related to described command.
[Example]	Example of using the command.

Listed below are the meanings of some of symbols that may be found in the command description:

0x	indicates the representation of the command hexadecimal value (for example 0x40 means HEX 40).
n, m, t, x, y	are optional parameters that can have different values.



2 IDENTIFICATION OF THE MODELS

NOMENCLATURE	DESCRIPTION
TG1260HIII	TG1260HIII base configuration
TG2460HIII	TG2460HIII base configuration
TG2460HIII EJC	TG2460HIII with ejector group
TG2480HIII	TG2480HIII base configuration
TL60III	TL60III base configuration
TL80III	TL80III base configuration



3 PAPER SPECIFICATION

Paper with black mark on the non-thermal side

The following images shows the placement of the black mark on the non-thermal side of the paper. The black mark can be placed anywhere on the whole width of the paper.

For more information about the use of paper with black mark see the user manual of each device.

All the dimensions shown in following figures are in millimetres.

TG1260HIII, TG2460HIII, TG2460HIII EJC

TG2480HIII

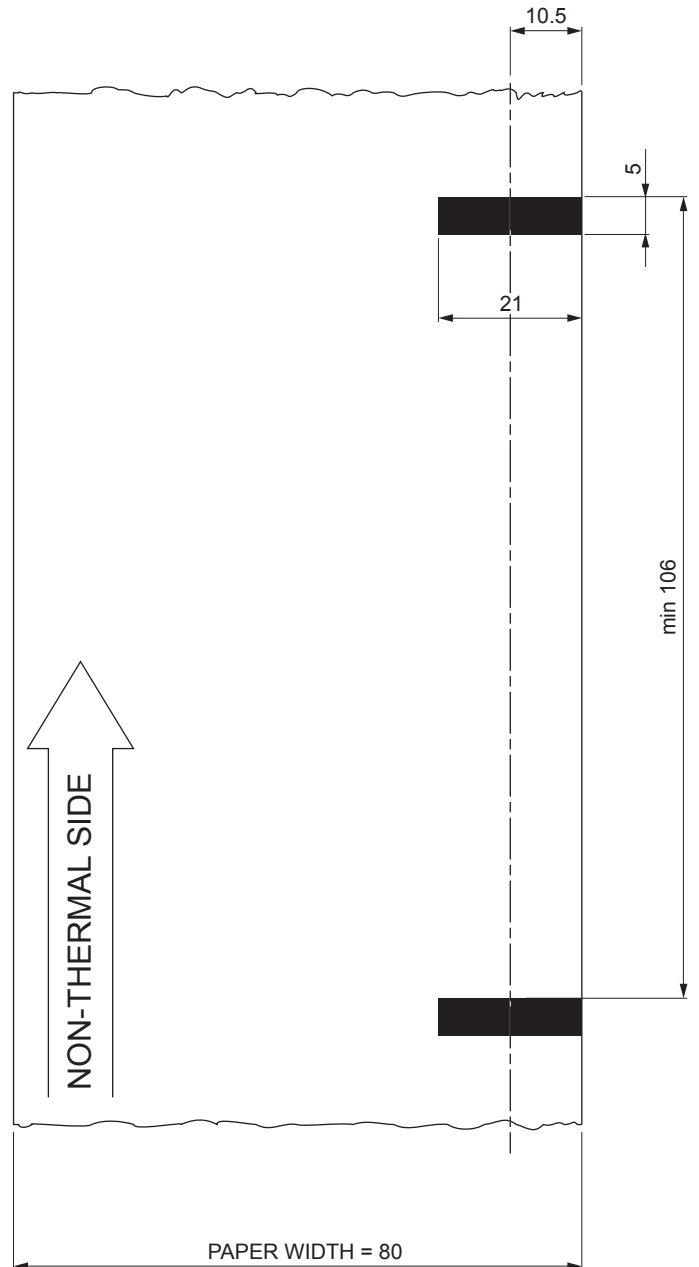
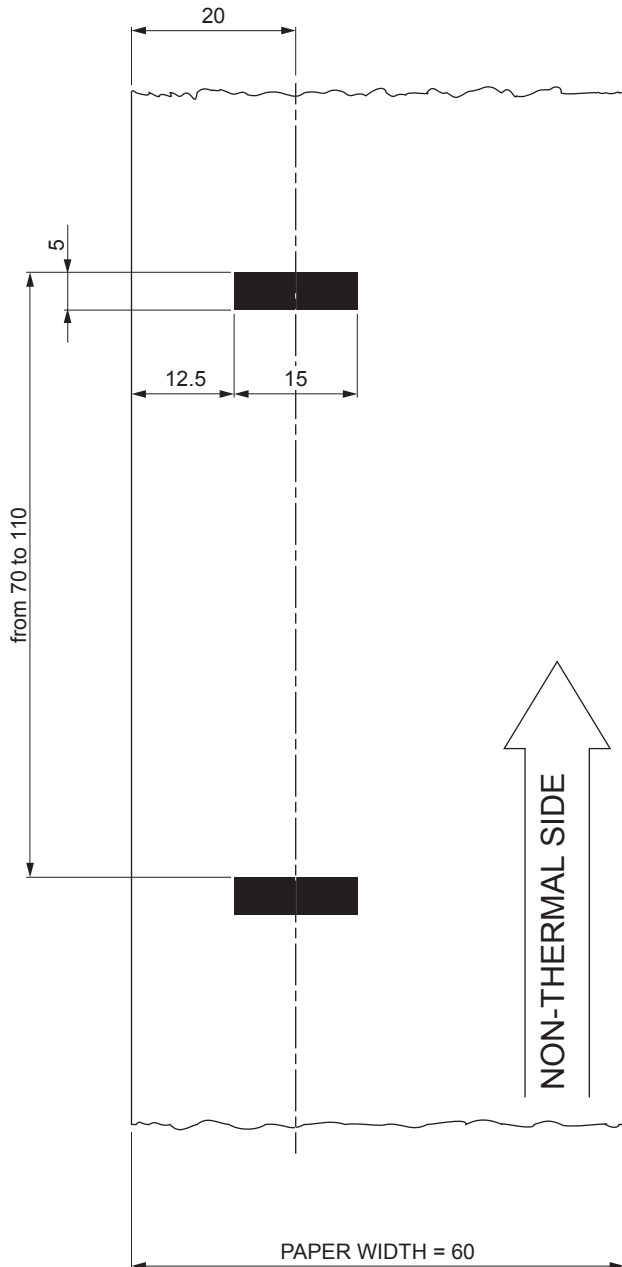



TL60III

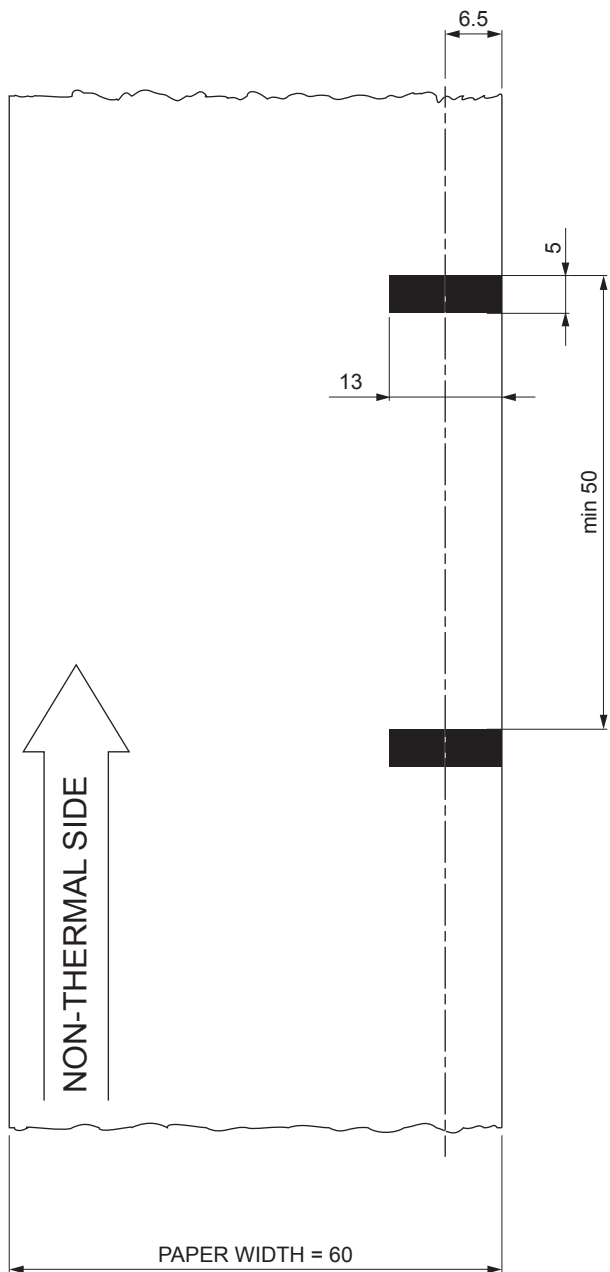

TL80III

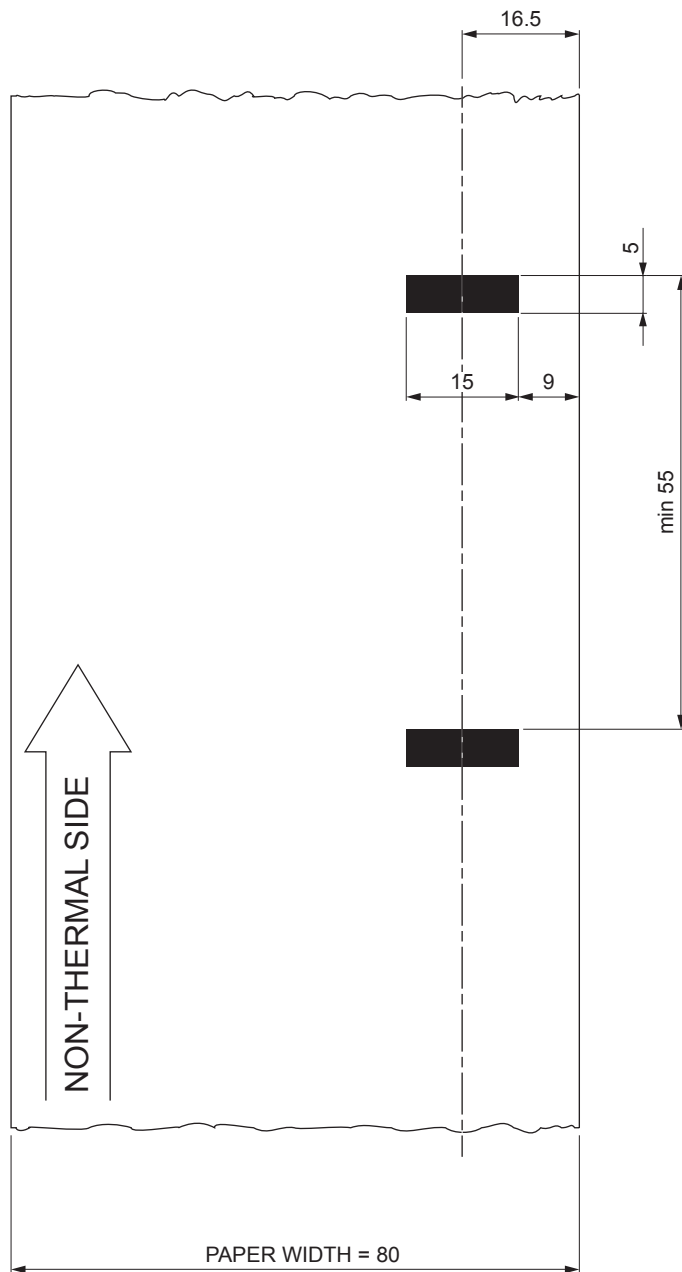



TGH EMULATION

1	COMMANDS LISTED IN ALPHANUMERIC ORDER.....	12
2	COMMANDS LISTED BY FUNCTION	16



1 COMMANDS LISTED IN ALPHANUMERIC ORDER

0x08	<BS>	101
0x09	<HT>	102
0x0A	<LF>	72
0x0D	<CR>	73
0x10 0x04	<DLE EOT>	79
0x18	<CAN>	49
0x1B 0x20	<ESC SP>	50
0x1B 0x21	<ESC !>	51
0x1B 0x24	<ESC \$>	103
0x1B 0x26	<ESC &>	53
0x1B 0x28 0x76	<ESC (v>	104
0x1B 0x2A	<ESC *>	92
0x1B 0x2D	<ESC ->	54
0x1B 0x30	<ESC 0>	69
0x1B 0x32	<ESC 2>	70
0x1B 0x33	<ESC 3>	71
0x1B 0x34	<ESC 4>	55
0x1B 0x3D	<ESC =>	126
0x1B 0x40	<ESC @>	127
0x1B 0x44	<ESC D>	105
0x1B 0x45	<ESC E>	56
0x1B 0x47	<ESC G>	57
0x1B 0x4A	<ESC J>	74
0x1B 0x4B	<ESC K>	128
0x1B 0x4D	<ESC M>	58
0x1B 0x52	<ESC R>	59



0x1B 0x56	<ESC V>	60
0x1B 0x5C	<ESC \>	107
0x1B 0x61	<ESC a>	108
0x1B 0x63 0x35	<ESC c 5>	129
0x1B 0x64	<ESC d>	75
0x1B 0x69	<ESC i>	111
0x1B 0x6D	<ESC m>	112
0x1B 0x74	<ESC t>	61
0x1B 0x78	<ESC x>	130
0x1B 0x7B	<ESC {>	63
0x1B 0xC1		64
0x1C 0x25	<FS %>	65
0x1C 0x3C	<FS <>	131
0x1C 0x50	<FS P>	118
0x1C 0x70	<FS p>	94
0x1C 0x71	<FS q>	96
0x1C 0x80		132
0x1C 0x81		133
0x1C 0x82		76
0x1C 0x83		77
0x1C 0x84		134
0x1C 0xB0		136
0x1C 0xC0 0x34		113
0x1C 0xC1		124
0x1C 0xEA		85
0x1C 0xEF		137



0x1D 0x21	<GS !>	66
0x1D 0x28 0x6B	<GS (k>	22
0x1D 0x28 0x6B [Fn 165]	<GS (k>	24
0x1D 0x28 0x6B [Fn 166]	<GS (k>	25
0x1D 0x28 0x6B [Fn 167]	<GS (k>	29
0x1D 0x28 0x6B [Fn 169]	<GS (k>	30
0x1D 0x28 0x6B [Fn 180]	<GS (k>	31
0x1D 0x28 0x6B [Fn 181]	<GS (k>	32
0x1D 0x28 0x6B [Fn 182]	<GS (k>	33
0x1D 0x28 0x6B [Fn Q65]	<GS (k>	35
0x1D 0x28 0x6B [Fn Q66]	<GS (k>	36
0x1D 0x28 0x6B [Fn Q67]	<GS (k>	37
0x1D 0x28 0x6B [Fn Q68]	<GS (k>	38
0x1D 0x28 0x6B [Fn Q80]	<GS (k>	39
0x1D 0x28 0x6B [Fn Q81]	<GS (k>	40
0x1D 0x2A	<GS *>	98
0x1D 0x42	<GS B>	68
0x1D 0x48	<GS H>	41
0x1D 0x49	<GS I>	138
0x1D 0x4C	<GS L>	109
0x1D 0x50	<GS P>	140
0x1D 0x57	<GS W>	110
0x1D 0x68	<GS h>	43
0x1D 0x6B	<GS k>	44
0x1D 0x70	<GS p>	99
0x1D 0x72	<GS r>	86
0x1D 0x77	<GS w>	47
0x1D 0x7C	<GS >	78



0x1D 0xDC	125
0x1D 0xE0	87
0x1D 0xE1	88
0x1D 0xE2	89
0x1D 0xE3	90
0x1D 0xE5	91
0x1D 0xE7	114
0x1D 0xE8	141
0x1D 0xF0	142
0x1D 0xF6	116
0x1D 0xF8	117



2 COMMANDS LISTED BY FUNCTION

COMMANDS FOR BARCODE PRINTING

0x1D 0x28 0x6B <GS (k>	22
Print two-dimensional barcode	
0x1D 0x28 0x6B [Fn 165] <GS (k>	24
Specify encoding scheme of QRcode barcode	
0x1D 0x28 0x6B [Fn 166] <GS (k>	25
Specify QRcode barcode version	
0x1D 0x28 0x6B [Fn 167] <GS (k>	29
Specify dot size of the module of the QRcode barcode	
0x1D 0x28 0x6B [Fn 169] <GS (k>	30
Specify the error correction level of the QRcode barcode	
0x1D 0x28 0x6B [Fn 180] <GS (k>	31
Store the data in the barcode save area for printing in QRcode format	
0x1D 0x28 0x6B [Fn 181] <GS (k>	32
Prints the data stored in the barcode save area in QRcode format	
0x1D 0x28 0x6B [Fn 182] <GS (k>	33
Transmit the QRcode barcode size in the barcode save area	
0x1D 0x28 0x6B [Fn Q65] <GS (k>	35
Specify the encoding scheme of DATAMATRIX barcode	
0x1D 0x28 0x6B [Fn Q66] <GS (k>	36
Set rotation of DATAMATRIX barcode	
0x1D 0x28 0x6B [Fn Q67] <GS (k>	37
Set dot size of the module of DATAMATRIX barcode	
0x1D 0x28 0x6B [Fn Q68] <GS (k>	38
Set size of DATAMATRIX barcode	
0x1D 0x28 0x6B [Fn Q80] <GS (k>	39
Store the DATAMATRIX barcode data in the barcode save area	
0x1D 0x28 0x6B [Fn Q81] <GS (k>	40
Encodes and prints the data stored in the barcode save area in DATAMATRIX format	
0x1D 0x48 <GS H>	41
Select printing position of HRI characters in 1D barcodes	
0x1D 0x68 <GS h>	43
Set 1D barcode height	
0x1D 0x6B <GS k>	44
Print 1D barcode	



0x1D 0x77	<GS w>	47
Set 1D barcode width		

CHARACTER COMMANDS

0x18	<CAN>	49
Cancel current line transmitted		
0x1B 0x20	<ESC SP>	50
Set right-side character spacing		
0x1B 0x21	<ESC !>	51
Select print modes		
0x1B 0x26	<ESC &>	53
Defines user-defined characters		
0x1B 0x2D	<ESC ->	54
Turn underline mode on or off		
0x1B 0x34	<ESC 4>	55
Turn italic mode on or off		
0x1B 0x45	<ESC E>	56
Turn bold mode on or off		
0x1B 0x47	<ESC G>	57
Turn double-strike mode on or off		
0x1B 0x4D	<ESC M>	58
Select character font		
0x1B 0x52	<ESC R>	59
Select an international character set		
0x1B 0x56	<ESC V>	60
Set 90° rotated print mode		
0x1B 0x74	<ESC t>	61
Select character code table		
0x1B 0x7B	<ESC {>	63
Turn upside-down printing mode on or off		
0x1B 0xC1	64
Select character pitch		
0x1C 0x25	<FS %>	65
Select the font type		
0x1D 0x21	<GS !>	66
Select character size		
0x1D 0x42	<GS B>	68
Turn black and white reverse printing mode on or off		



LINE SPACING COMMANDS

0x1B 0x30	<ESC 0>	69
Select 1/8-inch line spacing		
0x1B 0x32	<ESC 2>	70
Select 1/6-inch line spacing		
0x1B 0x33	<ESC 3>	71
Set line spacing		

PRINT COMMANDS

0x0A	<LF>	72
Print and line feed		
0x0D	<CR>	73
Print and carriage return		
0x1B 0x4A	<ESC J>	74
Print and paper feed		
0x1B 0x64	<ESC d>	75
Print and feed paper n lines		
0x1C 0x82		76
Print date		
0x1C 0x83		77
Print time		
0x1D 0x7C	<GS >	78
Set printing density		

STATUS COMMANDS

0x10 0x04	<DLE EOT>	79
Real-time status transmission		
0x1C 0xEA		85
Transmit the device serial number		
0x1D 0x72	<GS r>	86
Transmit status		
0x1D 0xE0		87
Enable or disable automatic FULL STATUS BACK		
0x1D 0xE1		88
Reading of length paper available before virtual paper-end		
0x1D 0xE2		89
Reading number of cuts performed by the autocutter		



0x1D 0xE3	90
Reading of length of printed paper	
0x1D 0xE5	91
Reading number of power up	

BIT-IMAGE COMMANDS

0x1B 0x2A	<ESC *>	92
Select bit image mode		
0x1C 0x70	<FS p>	94
Print NV bit image		
0x1C 0x71	<FS q>	96
Define NV bit image		
0x1D 0x2A	<GS *>	98
Logo storage		
0x1D 0x70	<GS p>	99
Print logo		

PRINT POSITION COMMANDS

0x08	<BS>	101
Back space		
0x09	<HT>	102
Horizontal tab		
0x1B 0x24	<ESC \$>	103
Set absolute print position		
0x1B 0x28 0x76	<ESC (v>	104
Set relative vertical print position		
0x1B 0x44	<ESC D>	105
Set horizontal tab positions		
0x1B 0x5C	<ESC \>	107
Set relative print position		
0x1B 0x61	<ESC a>	108
Select justification		
0x1D 0x4C	<GS L>	109
Set left margin		
0x1D 0x57	<GS W>	110
Set printing area width		



COMMANDS FOR MECHANISM CONTROL

0x1B 0x69	<ESC i>	111
Total cut		
0x1B 0x6D	<ESC m>	112
Partial cut		
0x1C 0xC0 0x34		113
Total cut and automatic paper moving back		

ALIGNMENT COMMANDS

0x1D 0xE7		114
Set black mark distance		
0x1D 0xF6		116
Align the ticket with the printhead		
0x1D 0xF8		117
Align the ticket with the autocutter		

EJECTOR COMMANDS

0x1C 0x50	<FS P>	118
Ejector management		

ANTI-JAMMING COMMANDS

0x1C 0xC1		124
Enable or disable automatic anti-jamming movement		
0x1D 0xDC		125
Perform the anti-jamming movement		

MISCELLANEOUS COMMANDS

0x1B 0x3D	<ESC =>	126
Select peripheral device		
0x1B 0x40	<ESC @>	127
Initialize device		
0x1B 0x4B	<ESC K>	128
Power on or off LED bar		
0x1B 0x63 0x35	<ESC c 5>	129
Enable or disable keys panel		



0x1B 0x78	<ESC x>	130
Select print mode		
0x1C 0x3C	<FS <>	131
Change emulation		
0x1C 0x80		132
Read date/time of the real time clock		
0x1C 0x81		133
Set date/time of the real time clock		
0x1C 0x84		134
Set user-defined date/time formats		
0x1C 0xB0		136
Minimum ticket length reading		
0x1C 0xEF		137
Set device in low power mode		
0x1D 0x49	<GS I>	138
Transmit device ID		
0x1D 0x50	<GS P>	140
Set horizontal and vertical motion units		
0x1D 0xE8		141
Set minimum ticket length		
0x1D 0xF0		142
Set print mode		



COMMANDS FOR BARCODE PRINTING

0x1D 0x28 0x6B

<GS (k>

Print two-dimensional barcode

Valid for

TG1260HIII
 TG2460HIII, TG2460HIII EJC
 TG2480HIII
 TL60III
 TL80III

[Format]

Hex	1D	28	6B	pL	pH	cn	fn
ASCII	GS	(k	pL	pH	cn	fn

[Range]

cn = 0x31, 0x51
 0x41 ≤ fn ≤ 0x45,
 0x50 ≤ fn ≤ 0x52

[Description]

Processes the data concerning two-dimensional barcode.

- Barcode type is specified by cn
- Function is specified by fn

cn	fn	FUNCTION	
0x31	0x41	Function 165	QRcode: Specify encoding scheme
0x31	0x42	Function 166	QRcode: Specify the selected version
0x31	0x43	Function 167	QRcode: Specify size of barcode
0x31	0x45	Function 169	QRcode: Specify the error correction level
0x31	0x50	Function 180	QRcode: Store the received data in the barcode save area
0x31	0x51	Function 181	QRcode: Print the barcode data
0x31	0x52	Function 182	QRcode: Transmit the barcode size in the barcode save area
0x51	0x41	Function Q65	DATAMATRIX: Set encoding scheme
0x51	0x42	Function Q66	DATAMATRIX: Set rotate
0x51	0x43	Function Q67	DATAMATRIX: Set dot size of the module
0x51	0x44	Function Q68	DATAMATRIX: Set size of barcode
0x51	0x50	Function Q80	DATAMATRIX: Store the received data in the barcode save area
0x51	0x51	Function Q81	DATAMATRIX: Print the barcode data in the barcode save area



[Notes]

[Default]

[Reference]

[Example]

0x1D 0x28 0x6B [Fn 165]

<GS (k>

Specify encoding scheme of QRcode barcode

Valid for
 TG1260HIII
 TG2460HIII, TG2460HIII EJC
 TG2480HIII
 TL60III
 TL80III

[Format] Hex 1D 28 6B pL pH 31 41 n1 n2
 ASCII GS (k pL pH 1 A n1 n2

[Range] (pL+pH × 256) = 4 (pL = 0x04, pH = 0x00)
 0x32 ≤ n1 ≤ 0x33
 n2 = 0x00

[Description] Specifies encoding type of QRcode barcode, based on the value of n1 as follows:

n1	ENCODING SCHEME
0x32	QRcode model 2
0x33	MicroQR

[Notes]

- QRcode: Encode all extended ASCII characters data up to a maximum length of 7089 numeric digits, 4296 alphabetic characters or 2953 bytes of data.
- pL and pH specify the number of successive bytes to be sent.
- MicroQR (a miniature version of the QRcode barcode for short message): Encode all numbers from 0 to 9 up to a maximum length of 35 characters.

[Default] n1 =0x32, n2 = 0x00

[Reference] [0x1D 0x28 0x6B](#)

[Example]

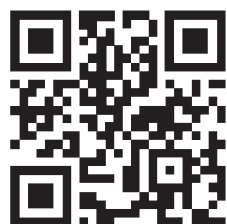

QRcode Model 2



MicroQR



0x1D 0x28 0x6B [Fn 166]

<GS (k >

Specify QRcode barcode version

Valid for	TG1260HIII TG2460HIII, TG2460HIII EJC TG2480HIII TL60III TL80III
-----------	--

[Format]	Hex 1D 28 6B pL pH 31 42 n ASCII GS (k pL pH 1 B n
----------	---

[Range]	(pL + pH × 256) = 3 (pL = 0x03, pH = 0x00) 0x00 ≤ n ≤ 0x28
---------	--

[Description]	Defines QRcode version to be printed.
---------------	---------------------------------------

- [Notes]
- If selected version has not enough capacity to store the saved amount of data, next smallest version capable of that capacity will be printed.
 - For QRcode version capacity according to ECC (Error Correction Capability) and data type refer to following table.
 - With n = 0x00 the selection of the version occurs automatically according to the one that allows the printing of the requested data.

n	VERSION	MODULES	ECC LEVEL	NUMERIC	ALPHANUMERIC	BINARY
0x00	AUTO	-	-	-	-	-
0x01	1	21 x 21	L	40	24	16
			M	33	19	13
			Q	26	15	10
			H	16	9	6
0x02	2	25 x 25	L	76	46	31
			M	62	37	25
			Q	47	28	19
			H	33	19	13
0x03	3	29 x 29	L	126	76	52
			M	100	60	41
			Q	76	46	31
			H	57	34	23
0x04	4	33 x 33	L	186	113	77
			M	148	89	61
			Q	110	66	45
			H	81	49	33
0x05	5	37 x 37	L	254	153	105
			M	201	121	83
			Q	143	86	59
			H	105	63	43



n	VERSION	MODULES	ECC LEVEL	NUMERIC	ALPHANUMERIC	BINARY
0x06	6	41 x 41	L	321	194	133
			M	254	153	105
			Q	177	107	73
			H	138	83	57
0x07	7	45 x 45	L	369	223	153
			M	292	177	121
			Q	206	124	85
			H	153	92	63
0x08	8	49 x 49	L	460	278	191
			M	364	220	151
			Q	258	156	107
			H	201	121	83
0x09	9	53 x 53	L	551	334	229
			M	431	261	179
			Q	311	188	129
			H	234	142	97
0x0A	10	57 x 57	L	651	394	270
			M	512	310	212
			Q	363	220	150
			H	287	173	118
0x0B	11	61 x 61	L	771	467	320
			M	603	365	250
			Q	426	258	176
			H	330	199	136
0x0C	12	65 x 65	L	882	534	366
			M	690	418	286
			Q	488	295	202
			H	373	226	154
0x0D	13	69 x 69	L	1021	618	424
			M	795	482	330
			Q	579	351	240
			H	426	258	176
0x0E	14	73 x 73	L	1100	666	457
			M	870	527	361
			Q	620	375	257
			H	467	282	193
0x0F	15	77 x 77	L	1249	757	519
			M	990	599	411
			Q	702	425	291
			H	529	320	219
0x10	16	81 x 81	L	1407	853	585
			M	1081	655	449
			Q	774	469	321
			H	601	364	249
0x11	17	85 x 85	L	1547	937	643
			M	1211	733	503
			Q	875	530	363
			H	673	407	279
0x12	18	89 x 89	L	1724	1045	717
			M	1345	815	559
			Q	947	573	393
			H	745	451	309



n	VERSION	MODULES	ECC LEVEL	NUMERIC	ALPHANUMERIC	BINARY
0x13	19	93 x 93	L	1902	1152	791
			M	1499	908	623
			Q	1062	643	441
			H	812	492	337
0x14	20	97 x 97	L	2060	1248	857
			M	1599	969	665
			Q	1158	701	481
			H	918	556	381
0x15	21	101 x 101	L	2231	1351	928
			M	1707	1034	710
			Q	1223	741	508
			H	968	586	402
0x16	22	105 x 105	L	2408	1459	1002
			M	1871	1133	778
			Q	1357	822	564
			H	1055	639	438
0x17	23	109 x 109	L	2619	1587	1090
			M	2058	1247	856
			Q	1467	889	610
			H	1107	671	460
0x18	24	113 x 113	L	2811	1703	1170
			M	2187	1325	90
			Q	1587	92	60
			H	1227	73	50
0x19	25	117 x 117	L	3056	1852	1272
			M	2394	1450	96
			Q	1717	1040	74
			H	1285	78	54
0x1A	26	121 x 121	L	3282	198	1366
			M	2543	1541	1058
			Q	1803	1093	70
			H	1424	83	52
0x1B	27	125 x 125	L	3516	2131	1464
			M	2700	1636	1124
			Q	1932	1171	84
			H	1500	89	64
0x1C	28	129 x 129	L	3668	2222	1527
			M	2856	1731	118
			Q	2084	1262	87
			H	1580	97	67
0x1D	29	133 x 133	L	3908	2368	1627
			M	3034	1838	1263
			Q	2180	1321	97
			H	1676	1015	67
0x1E	30	137 x 137	L	4157	251	1731
			M	3288	1993	136
			Q	2357	1428	91
			H	1781	107	71
0x1F	31	141 x 141	L	4416	2676	183
			M	3485	2112	1451
			Q	2472	1498	102
			H	1896	114	69



n	VERSION	MODULES	ECC LEVEL	NUMERIC	ALPHANUMERIC	BINARY
0x20	32	145 x 145	L	4685	283	1951
			M	3692	2237	1537
			Q	266	1617	1111
			H	2021	1225	81
0x21	33	149 x 149	L	4964	3008	2067
			M	3908	2368	1627
			Q	2804	16	1167
			H	2156	1306	87
0x22	34	153 x 153	L	5252	3182	2187
			M	4133	2505	1721
			Q	2948	1786	1227
			H	2300	1393	97
0x23	35	157 x 157	L	5528	3350	2302
			M	4342	2631	1808
			Q	3080	1866	1282
			H	2360	1430	92
0x24	36	161 x 161	L	5835	3536	2430
			M	4587	277	1910
			Q	3243	1965	1350
			H	2523	152	1050
0x25	37	165 x 165	L	6152	3728	2562
			M	4774	2893	1988
			Q	3416	2070	1422
			H	2624	1590	1092
0x26	38	169 x 169	L	6478	3926	2698
			M	5038	3053	2098
			Q	3598	2180	1498
			H	2734	1657	1138
0x27	39	173 x 173	L	6742	4086	2808
			M	5312	321	2212
			Q	3790	2297	1578
			H	2926	1773	1218
0x28	40	177 x 177	L	7088	4295	2952
			M	5595	3390	2330
			Q	3992	241	1662
			H	3056	1851	1272

[Default] n = 0x00

[Reference] [0x1D 0x28 0x6B](#)

[Example] To select QRcode version 8 the command sequence is:
0x1D 0x28 0x6B 0x03 0x00 0x31 0x42 0x08

0x1D 0x28 0x6B [Fn 167]

<GS (k>

Specify dot size of the module of the QRcode barcode

Valid for	TG1260HIII TG2460HIII, TG2460HIII EJC TG2480HIII TL60III TL80III
-----------	--

[Format]	Hex	1D	28	6B	pL	pH	31	43	n
	ASCII	GS	(k	pL	pH	1	C	n

[Range] (pL + pH × 256) = 3 (pL = 0x03, pH = 0x00)
0x02 ≤ n ≤ 0x18

[Description] Specifies numbers of dots for each pixel of QRcode barcode.

[Notes] pL and pH specify the number of successive bytes to be sent.

[Default] n = 0x06

[Reference] [0x1D 0x28 0x6B](#)

[Example]

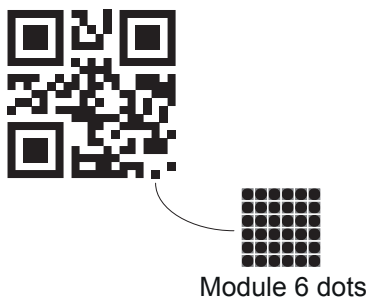

0x1D 0x28 0x6B [Fn 169]

<GS (k>

Specify the error correction level of the QRcode barcode

Valid for
 TG1260HIII
 TG2460HIII, TG2460HIII EJC
 TG2480HIII
 TL60III
 TL80III

[Format] Hex 1D 28 6B pL pH 31 45 n
 ASCII GS (k pL pH 1 E n

[Range] (pL + pH × 256) = 3 (pL = 0x03, pH = 0x00)
 0x30 ≤ n ≤ 0x34

[Description] Specifies the ECC level (Error Correction Capability) of QRcode barcode.

n	ECC level	
0x30	AUTO	
0x31	ECC L = approx 20% of symbol	Recovery Capability = approx 7%
0x32	ECC M = approx 37% of symbol	Recovery Capability = approx 15%
0x33	ECC Q = approx 55% of symbol	Recovery Capability = approx 25%
0x34	ECC H = approx 65% of symbol	Recovery Capability = approx 30%

[Notes] pL and pH specify the number of successive bytes to be sent.

[Default] n = 0x30

[Reference] [0x1D 0x28 0x6B](#)

[Example]

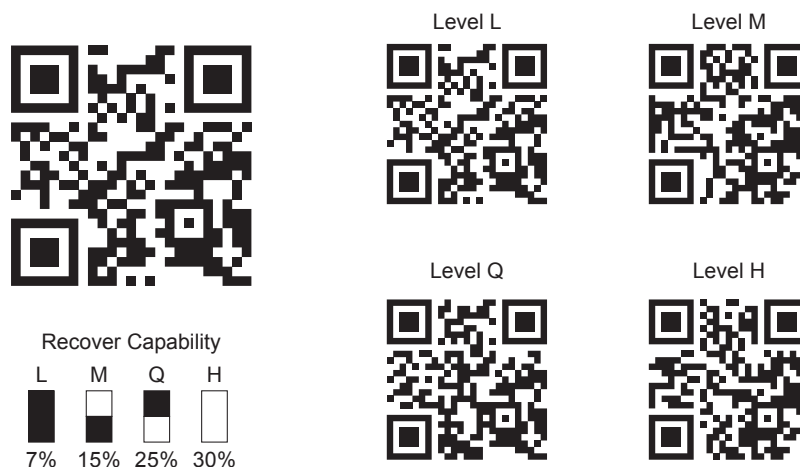



0x1D 0x28 0x6B [Fn 180]

<GS (k>

Store the data in the barcode save area for printing in QRcode format

Valid for	TG1260HIII TG2460HIII, TG2460HIII EJC TG2480HIII TL60III TL80III									
[Format]	Hex	1D	28	6B	pL	pH	31	50	31	d1...dk
	ASCII	GS	(k	pL	pH	1	P	1	d1...dk
[Range]	$0x00 \leq d \leq 0xFF$ $k = (pL + pH \times 256) - 3$ <ul style="list-style-type: none"> QRcode barcode only with binary characters (8 bit): $4 \leq (pL + pH \times 256) \leq 2957$ (0x00 ≤ pL ≤ 0xFF, 0x00 ≤ pH ≤ 0x0B) QRcode barcode only with alphanumeric characters: $4 \leq (pL + pH \times 256) \leq 4300$ (0x00 ≤ pL ≤ 0xFF, 0x00 ≤ pH ≤ 0x10) QRcode barcode only with numeric characters: $4 \leq (pL + pH \times 256) \leq 7093$ (0x00 ≤ pL ≤ 0xFF, 0x00 ≤ pH ≤ 0x1B) 									
[Description]	Store the data (d1...dk) in the barcode save area for printing in QRcode format.									
[Notes]	<ul style="list-style-type: none"> Data stored in the barcode save area by this function are processed by Function 181 and then reserved. pL and pH specify the number of successive bytes to be sent. k bytes of d1...dk are processed as barcode data. Specify only the data code word of the barcode with this function. 									
[Default]										
[Reference]	0x1D 0x28 0x6B									
[Example]										



0x1D 0x28 0x6B [Fn 181]

<GS (k>

Prints the data stored in the barcode save area in QRcode format

Valid for	TG1260HIII
	TG2460HIII, TG2460HIII EJC
	TG2480HIII
	TL60III
	TL80III

[Format]	Hex	1D	28	6B	pL	pH	31	51	31
	ASCII	GS	(k	pL	pH	1	Q	1

[Range] (pL + pH × 256) = 3 (pL = 0x03, pH = 0x00)

[Description] Prints the data stored in the barcode save area in QRcode format.

[Notes] pL and pH specify the number of successive bytes to be sent.

[Default]

[Reference] [0x1D 0x28 0x6B](#)

[Example]

0x1D 0x28 0x6B [Fn 182]

<GS (k>

Transmit the QRcode barcode size in the barcode save area

Valid for	TG1260HIII TG2460HIII, TG2460HIII EJC TG2480HIII TL60III TL80III
-----------	--

[Format]	Hex 1D 28 6B pL pH 31 52 30 ASCII GS (k pL pH 1 R 0
----------	--

[Range] (pL+pH × 256) = 3 (pL = 0x03, pH = 0x00)

[Description] Transmits the QRcode barcode size in the barcode save area.

- [Notes]
- To store the data in the device barcode save area use the [Function 180](#).
 - In standard mode, use this function when device is at the beginning of a line or when there is no data in the print buffer.
 - pL and pH specify the number of successive bytes to be sent.
 - The size information for each data is as follows:

SEND DATA	HEX	DATA
Header	37	1 byte
Identifier	36	1 byte
Horizontal size ⁽¹⁾	30-39	1 - 5 byte
Separator	1F	1 byte
Vertical size ⁽¹⁾	30-39	1 - 5 byte
Separator	1F	1 byte
Fixed value	31	1 byte
Separator	1F	1 byte
Other information ⁽²⁾	30 or 31	1 byte
NUL	00	1 byte

(1) "Horizontal size" and "vertical size" indicate the number of dots of the symbol.
The values of the vertical size and horizontal size are converted to characters and sent starting from the high order end (ex: When horizontal size is 120 dots, horizontal size is 0x31 0x32 0x30, which is 3 bytes of data).

(2) "Other information" indicates whether printing of the data in the symbol storage area is possible or impossible. The "Other information" is the following:

HEX	CONDITION
30	Printing is possible
31	Printing is impossible



- Size information indicates size of symbol that is printed by [Function 181](#).
- The quiet zone is not included in the size information.
- If “other information” is “Printing is impossible“(0x31), use one of the solutions shown below:

CAUSE	SOLUTION
There are data in the print buffer in the standard mode	Clear the data in the print buffer by executing 0x0A , 0x0D , 0x1B 0x4A print commands.
Symbol is bigger than the current print area.	Expand the print area by 0x1D 0x57 , 0x1B 0x24 . Reduce the module size by using Function 167 . Lower the error correction level by using Function 169 .
The data in the symbol storage area is too large.	Send correct data by using Function 180 . Lower the error correction level by using Function 169 .
There is no data in the symbol storage area.	Send data to the symbol storage area by using Function 180 .

[Default]

[Reference] [0x1D](#) [0x28](#) [0x6B](#)

[Example] A possible device response can be:
[0x37](#) [0x36](#) [0x31](#) [0x32](#) [0x36](#) [0x1F](#) [0x31](#) [0x32](#) [0x36](#) [0x1F](#) [0x31](#) [0x1F](#) [0x30](#) [0x00](#)

where:

0x37	header
0x36	identifier
0x31 0x32 0x36	horizontal size 126 dots (0x31 = 1, 0x32 = 2, 0x36 = 6)
0x1F	separator
0x31 0x32 0x36	vertical size 126 dots (0x31 = 1, 0x32 = 2, 0x36 = 6)
0x1F	separator
0x31	fixed value
0x1F	separator
0x30	printing possible
0x00	NUL (end of text character)



0x1D 0x28 0x6B [Fn Q65]

<GS (k>

Specify the encoding scheme of DATAMATRIX barcode

Valid for	TG1260HIII TG2460HIII, TG2460HIII EJC TG2480HIII TL60III TL80III
-----------	--

[Format]	Hex 1D 28 6B pL pH 51 41 n ASCII GS (k pL pH Q A n
----------	---

[Range]	(pL + pH × 256) = 3 (pL = 0x03, pH = 0x00) 0x00 ≤ n ≤ 0x06
---------	--

[Description] Set the encoding scheme for the DATAMATRIX barcode based on the value of n as follows:

n	ENCODING
0x00	ASCII
0x01	C40
0x02	Text
0x03	X12
0x04	Edifact
0x05	Base256
0x06	AutoBest

[Notes] pL and pH specify the number of successive bytes to be sent.

[Default]

[Reference] [0x1D 0x28 0x6B](#)

[Example] To set encoding = ASCII, the command sequence is:
0x1D 0x28 0x6B 0x03 0x00 0x51 0x41 0x00



0x1D 0x28 0x6B [Fn Q66]

<GS (k>

Set rotation of DATAMATRIX barcode

Valid for TG1260HIII
 TG2460HIII, TG2460HIII EJC
 TG2480HIII
 TL60III
 TL80III

[Format] Hex 1D 28 6B pL pH 51 42 n
 ASCII GS (k pL pH Q B n

[Range] (pL + pH × 256) = 3 (pL = 0x03, pH = 0x00)
 n = 0x00, 0x01

[Description] Set the rotation for the DATAMATRIX barcode based on the value of n as follows:

n	ROTATION
0x00	No rotation
0x01	Rotation

[Notes] pL and pH specify the number of successive bytes to be sent.

[Default]

[Reference] [0x1D 0x28 0x6B](#)

[Example]



0x1D 0x28 0x6B [Fn Q67]

<GS (k>

Set dot size of the module of DATAMATRIX barcode

Valid for	TG1260HIII TG2460HIII, TG2460HIII EJC TG2480HIII TL60III TL80III								
-----------	--	--	--	--	--	--	--	--	--

[Format]	Hex	1D	28	6B	pL	pH	51	43	n
	ASCII	GS	(k	pL	pH	Q	C	n

[Range] (pL + pH × 256) = 3 (pL = 0x03, pH = 0x00)
0x02 ≤ n ≤ 0x18

[Description] Set dot size of the module of the DATAMATRIX barcode:
n = dot dimension

[Notes] pL and pH specify the number of successive bytes to be sent.

[Default] n = 0x06

[Reference] [0x1D 0x28 0x6B](#)

[Example] To set dot size = 6 the command sequence is:
0x1D 0x28 0x6B 0x03 0x00 0x51 0x43 0x06



0x1D 0x28 0x6B [Fn Q68]

<GS (k>

Set size of DATAMATRIX barcode

Valid for TG1260HIII
TG2460HIII, TG2460HIII EJC
TG2480HIII
TL60III
TL80III

[Format] Hex 1D 28 6B pL pH 51 44 n
ASCII GS (k pL pH Q D n

[Range] (pL + pH × 256) = 3 (pL = 0x03, pH = 0x00)
0x00 ≤ n ≤ 0x1D

[Description] Set the size of DATAMATRIX barcode based on the value of n as follows:

n	BARCODE SIZE	n	BARCODE SIZE
0x00	AUTO	0x0F	52 x 52
0x01	10 x 10	0x10	64 x 64
0x02	12 x 12	0x11	72 x 72
0x03	14 x 14	0x12	80 x 80
0x04	16 x 16	0x13	88 x 88
0x05	18 x 18	0x14	96 x 96
0x06	20 x 20	0x15	104 x 104
0x07	22 x 22	0x16	120 x 120
0x08	24 x 24	0x17	132 x 132
0x09	26 x 26	0x18	144 x 144
0x0A	32 x 32	0x19	8 x 18
0x0B	36 x 36	0x1A	8 x 32
0x0C	40 x 40	0x1B	12 x 26
0x0D	44 x 44	0x1C	12 x 36
0x0E	48 x 48	0x1D	16 x 36

[Notes] pL and pH specify the number of successive bytes to be sent.

[Default] n = 0x00

[Reference] [0x1D 0x28 0x6B](#)

[Example]



0x1D 0x28 0x6B [Fn Q80]

<GS (k)>

Store the DATAMATRIX barcode data in the barcode save area

Valid for	TG1260HIII TG2460HIII, TG2460HIII EJC TG2480HIII TL60III TL80III									
[Format]	Hex	1D	28	6B	pL	pH	51	50	33	d1...dk
	ASCII	GS	(k	pL	pH	Q	P	3	d1...dk
[Range]	<p>$0x00 \leq d \leq 0xFF$ $k = (pL + pH \times 256) - 3$</p> <ul style="list-style-type: none"> DATAMATRIX barcode only with ASCII characters (8 bit) : $4 \leq (pL + pH \times 256) \leq 1560$ ($0x00 \leq pL \leq 0xFF$, $0x00 \leq pH \leq 0x06$) DATAMATRIX barcode only with alphanumeric characters: $4 \leq (pL + pH \times 256) \leq 2339$ ($0x00 \leq pL \leq 0xFF$, $0x00 \leq pH \leq 0x09$) DATAMATRIX barcode only with numeric characters: $4 \leq (pL + pH \times 256) \leq 3120$ ($0x00 \leq pL \leq 0xFF$, $0x00 \leq pH \leq 0x0C$) 									
[Description]	Store the DATAMATRIX barcode data (d1...dk) in the barcode save area.									
[Notes]	<ul style="list-style-type: none"> Data stored in the barcode save area by this function are processed by Function Q81 and then reserved. pL and pH specify the number of successive bytes to be sent. k bytes of d1...dk are processed as barcode data. Specify only the data code word of the barcode with this function. Be sure not to include the control data in the data d1...dk because they are added automatically by the device. 									
[Default]										
[Reference]	0x1D 0x28 0x6B									
[Example]										



0x1D 0x28 0x6B [Fn Q81]

<GS (k>

Encodes and prints the data stored in the barcode save area in DATAMATRIX format

Valid for	TG1260HIII TG2460HIII, TG2460HIII EJC TG2480HIII TL60III TL80III
-----------	--

[Format]	Hex 1D 28 6B pL pH 51 51 33
	ASCII GS (k pL pH Q Q 3

[Range] (pL + pH × 256) = 3 (pL = 0x03, pH = 0x00)

[Description] Encodes and prints the data stored in the barcode save area in DATAMATRIX format.

- [Notes]
- In standard mode, use this function when device is at the beginning of a line or there is no data in the print buffer.
 - pL and pH specify the number of successive bytes to be sent.
 - A barcode that size exceeds the printing area cannot be printed.
 - If there is any error described below in the data of the barcode save area, it cannot be printed.
 - There is no data ([Function Q80](#) is not processed).
 - If [(number of columns × number of rows) < number of code word] when auto processing is specified for number of columns and number of rows.
 - Number of code word exceeds 928 in the data area.
 - When auto processing ([Function Q65](#)) is specified, the number of columns is calculated by the current printing area, module width ([Function Q67](#)) and the code word in the data area. Maximum number of the columns is 30.

[Default]

[Reference] [0x1D 0x28 0x6B](#)

[Example] To print the DATAMATRIX barcode data the command sequence is:
0x1D 0x28 0x6B 0x03 0x00 0x51 0x51 0x33



0x1D 0x48

<GS H>

Select printing position of HRI characters in 1D barcodes

Valid for	TG1260HIII TG2460HIII, TG2460HIII EJC TG2480HIII TL60III TL80III
-----------	--

[Format]	Hex 1D 48 n ASCII GS H n
----------	--

[Range]	0x00 ≤ n ≤ 0x03 0x30 ≤ n ≤ 0x33
---------	------------------------------------

[Description] Selects the print position of HRI (Human Readable Interpretation) characters when printing a 1D barcode, based on the value of n as follows:

n	FUNCTION
0x00, 0x30	Not printed
0x01, 0x31	Above the barcode
0x02, 0x32	Below the barcode
0x03, 0x33	Both above and below the barcode

[Notes]

[Default] n = 0x00

[Reference] [0x1D 0x6B](#)



[Example]

Not printed

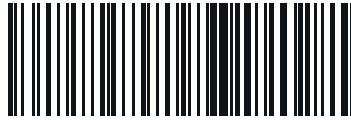

Above the barcode

ABCDEFGH123456

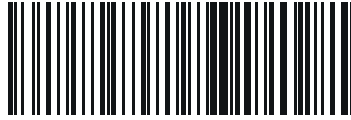

Below the barcode

ABCDEFGH123456

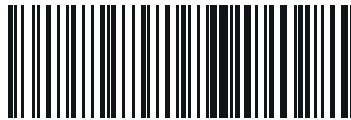

Both above and below the barcode

ABCDEFGH123456

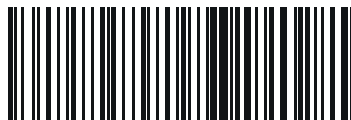

ABCDEFGH123456



0x1D 0x68

<GS h>

Set 1D barcode height

Valid for	TG1260HIII TG2460HIII, TG2460HIII EJC TG2480HIII TL60III TL80III
-----------	--

[Format]	Hex 1D 68 n ASCII GS h n
----------	---

[Range] $0x01 \leq n \leq 0xFF$

[Description] Sets the height of the 1D barcode.
n specifies the number of vertical dots.

[Notes]

[Default] n = 0xA2 (20.25 mm)

[Reference] [0x1D 0x6B](#)

[Example] To print a barcode with height of 15 mm, the command sequence is:
0x1D 0x68 0x78

Where:

15 mm = 15 × 8 dots = 120 dots which converted in hexadecimal value = 0x78



0x1D 0x6B

<GS k>

Print 1D barcode

Valid for	TG1260HIII TG2460HIII, TG2460HIII EJC TG2480HIII TL60III TL80III
-----------	--

[Format 1]	Hex 1D 6B m [d1..dk] 00 ASCII GS k m [d1..dk] NUL
------------	---

[Format 2]	Hex 1D 6B m n [d1..dn] ASCII GS k m n [d1..dn]
------------	--

[Range]	Format 1 0x00 ≤ m ≤ 0x08, m = 0x14 Format 2 0x41 ≤ m ≤ 0x49, m = 0x5A
---------	--

[Description] Selects a 1D barcode system and prints the 1D barcode based on the value of m as follows:

Format 1

m	BARCODE SYSTEM	NUMBER OF CHARACTERS	REMARKS
0x00	UPC-A	0x0B ≤ k ≤ 0x0C	0x30 ≤ d ≤ 0x39
0x01	UPC-E	0x0B ≤ k ≤ 0x0C	0x30 ≤ d ≤ 0x39
0x02	EAN13 (JAN)	0x0C ≤ k ≤ 0x0D	0x30 ≤ d ≤ 0x39
0x03	EAN8 (JAN)	0x07 ≤ k ≤ 0x08	0x30 ≤ d ≤ 0x39
0x04	CODE39	0x01 ≤ k	0x30 ≤ d ≤ 0x39, 0x41 ≤ d ≤ 0x5A, 0x20, 0x24, 0x25, 0x2B, 0x2D, 0x2E, 0x2F
0x05	ITF	0x01 ≤ k (even number)	0x30 ≤ d ≤ 0x39
0x06	CODABAR	0x01 ≤ k	0x30 ≤ d ≤ 0x39, 0x41 ≤ d1 ≤ 0x44, 0x24, 0x2B, 0x2D, 0x2E, 0x2F, 0x3A
0x07	CODE93	0x01 ≤ k ≤ 0xFF	0x01 ≤ d ≤ 0x7F
0x08	CODE128	0x02 ≤ k ≤ 0xFF	0x01 ≤ d ≤ 0x7F
0x14	CODE32	0x08 ≤ k ≤ 0x09	0x30 ≤ d ≤ 0x39



Format 2

m	BARCODE SYSTEM	NUMBER OF CHARACTERS	REMARKS
0x41	UPC-A	$0x0B \leq n \leq 0x0C$	$0x30 \leq d \leq 0x39$
0x42	UPC-E	$0x0B \leq n \leq 0x0C$	$0x30 \leq d \leq 0x39$
0x43	EAN13 (JAN)	$0x0C \leq n \leq 0x0D$	$0x30 \leq d \leq 0x39$
0x44	EAN8 (JAN)	$0x07 \leq n \leq 0x08$	$0x30 \leq d \leq 0x39$
0x45	CODE39	$0x01 \leq n \leq 0xFF$	$0x30 \leq d \leq 0x39$, $0x41 \leq d \leq 0x5A$, $0x20, 0x24, 0x25, 0x2B,$ $0x2D, 0x2E, 0x2F$
0x46	ITF	$0x01 \leq n \leq 0xFF$	$0x30 \leq d \leq 0x39$
0x47	CODABAR	$0x01 \leq n \leq 0xFF$	$0x30 \leq d \leq 0x39$, $0x41 \leq d1 \leq 0x44$, $0x24, 0x2B, 0x2D,$ $0x2E, 0x2F, 0x3A$
0x48	CODE93	$0x01 \leq n \leq 0xFF$	$0x01 \leq d \leq 0x7F$
0x49	CODE128	$0x02 \leq n \leq 0xFF$	$0x01 \leq d \leq 0x7F$
0x5A	CODE32	$0x08 \leq n \leq 0x09$	$0x30 \leq d \leq 0x39$

[Notes]

- If d is outside of the specified range, the device prints the following message: "BARCODE GENERATOR IS NOT OK!" and processes the data which follows as normal data.
- If the horizontal size exceeds the printing area, the device only feeds the paper.
- This command feeds as much paper as is required to print the barcode, regardless of the line spacing specified by `0x1B 0x32` or `0x1B 0x33`.
- After printing the barcode, this command sets the print position to the beginning of the line.
- This command is not affected by print modes (bold, double-strike, underline or character size), except for upside-down and justification mode.

Format 1

- This command ends with a NUL code.
- When the barcode system used is UPC-A or UPC-E, the device prints the barcode data after receiving 11 (without check digit) or 12 (with check digit) bytes barcode data.
- When the barcode system used is EAN13, the device prints the barcode data after receiving 12 (without check digit) or 13 (with check digit) bytes barcode data.
- When the barcode system used is EAN8, the device prints the barcode data after receiving 7 (without check digit) or 8 (with check digit) bytes barcode data.
- The number of data for ITF barcode must be even numbers. When an odd number of data is input, the device ignores the last received data.

Format 2

If n is outside of the specified range, the device stops command processing and processes the following data as normal data.

When CODE93 is used:

- The device prints an HRI character (o) as a start character at the beginning of the HRI character string.



- The device prints an HRI character (o) as a stop character at the end of the HRI character string.
- The device prints an HRI character (n) as a control character (0x00 to 0x1F and 0x7F).

When CODE128 is used, please note the following regarding data transmission:

- The top part of the barcode data string must be a code set selection character (CODE A, CODE B or CODE C) which selects the first code set.
- Special characters are defined by combining two characters “{” and one character. ASCII character “{” is defined by transmitting “{{” twice, consecutively.

SPECIFIC CHARACTER	DATA TRANSMISSION	
	ASCII	HEX
SHIFT	{S	7B, 53
CODE A	{A	7B, 41
CODE B	{B	7B, 42
CODE C	{C	7B, 43
FNC1	{1	7B, 31
FNC2	{2	7B, 32
FNC3	{3	7B, 33
FNC4	{4	7B, 34
{‘	{{	7B, 7B

When UPC-E is used, introducing the barcode characters, the device prints:

TRANSMITTED DATA											PRINTED DATA					
d1	d2	d3	d4	d5	d6	d7	d8	d9	d10	d11	d2	d3	d9	d10	d11	
0	0-9	0-9	0	0	0	0	0	0-9	0-9	0-9	d2	d3	d9	d10	d11	0
0	0-9	0-9	1	0	0	0	0	0-9	0-9	0-9	d2	d3	d9	d10	d11	1
0	0-9	0-9	2	0	0	0	0	0-9	0-9	0-9	d2	d3	d9	d10	d11	2
0	0-9	0-9	3-9	0	0	0	0	0	0-9	0-9	d2	d3	d4	d10	d11	3
0	0-9	0-9	0-9	1-9	0	0	0	0	0	0-9	d2	d3	d4	d5	d11	4
0	0-9	0-9	0-9	0-9	1-9	0	0	0	0	5-9	d2	d3	d4	d5	d6	d11

[Default]

[Reference] [0x1D 0x48, 0x1D 0x68, 0x1D 0x77](#)

[Example]

Format 1: Example for printing a CODE39 barcode:
0x1D 0x6B 0x04 0x54 0x45 0x53 0x54 0x00

Format 2: Example for printing a CODE39 barcode:
0x1D 0x6B 0x45 0x04 0x54 0x45 0x53 0x54



0x1D 0x77

<GS w>

Set 1D barcode width

Valid for TG1260HIII
 TG2460HIII, TG2460HIII EJC
 TG2480HIII
 TL60III
 TL80III

[Format] Hex 1D 77 n
 ASCII GS w n

[Range] $0x01 \leq n \leq 0x06$

[Description] Sets the horizontal size of the 1D barcode. n specifies the barcode width as follows:

n	MODULE WIDTH (mm)
0x01	0.125
0x02	0.25
0x03	0.375
0x04	0.5
0x05	0.625
0x06	0.75

n		WIDE BAR / NARROW BAR RATIO
If n < 0x80	0x01, 0x02, 0x03, 0x04, 0x05, 0x06	3:1
	0x81	3:1
If n > 0x80	0x82	2.5:1
	0x83	2.33:1
	0x84	2.25:1
	0x85	3:1
	0x86	3:1

[Notes] This command is enabled only when inserted at the beginning of a line.



[Default] n = 0x03

[Reference] 0x1D 0x6B

[Example]

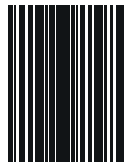

n = 0x01

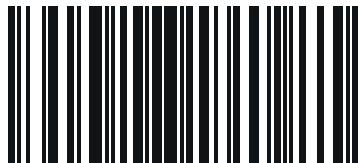

n = 0x03



CHARACTER COMMANDS

0x18

<CAN>

Cancel current line transmitted

Valid for	TG1260HIII
	TG2460HIII, TG2460HIII EJC
	TG2480HIII
	TL60III
	TL80III

[Format]	Hex	18
	ASCII	CAN

[Range]

[Description] Deletes current line transmitted.

[Notes]

- Sets the print position to the beginning of the line.
- This command does not clear the receive buffer.

[Default]

[Reference]

[Example]

0x1B 0x20

<ESC SP>

Set right-side character spacing

Valid for
 TG1260HIII
 TG2460HIII, TG2460HIII EJC
 TG2480HIII
 TL60III
 TL80III

[Format] Hex 1B 20 n
 ASCII ESC SP n

[Range] 0x00 ≤ n ≤ 0xFF

[Description] Sets the character spacing for the right side of the character to [n × horizontal or vertical motion units].

- [Notes]
- The right character spacing for double-width mode is twice the normal value. When the characters are enlarged, the right side character spacing is m (2 or 4) times the normal value.
 - The horizontal and vertical motion units are specified by **0x1D 0x50**. Changing the horizontal or vertical motion units does not affect the current right side spacing.
 - The **0x1D 0x50** command can change the horizontal (and vertical) motion unit. However, the value cannot be less than the minimum horizontal movement amount.
 - The maximum right side spacing is 32 mm.
 - In standard mode, the horizontal motion unit is used.

[Default] n = 0x00

[Reference] **0x1D 0x50**

[Example]

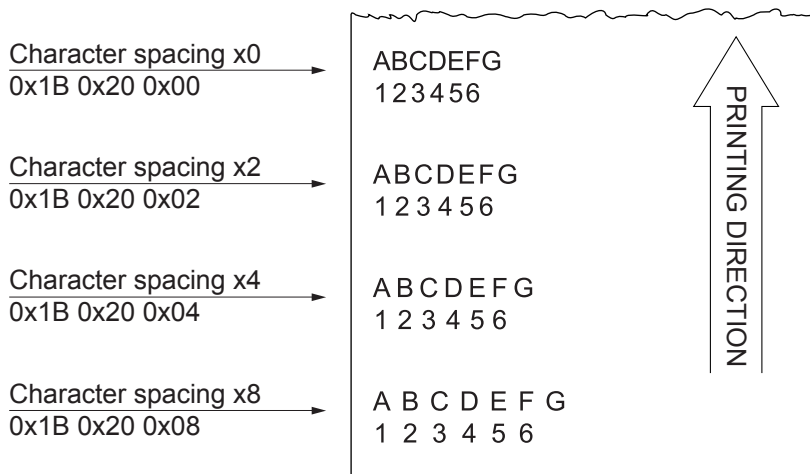



0x1B 0x21

<ESC !>

Select print modes

Valid for TG1260HIII
TG2460HIII, TG2460HIII EJC
TG2480HIII
TL60III
TL80III

[Format] Hex 1B 21 n
ASCII ESC ! n

[Range] $0x00 \leq n \leq 0xFF$

[Description] Selects print modes based on the value of n as follows:

BIT	OFF/ON	n	FUNCTION	11/15 dpi	15/20 dpi	20/25 dpi
0	Off	0x00	Character font A selected	18 x 24	14 x 24	10 x 24
	On	0x01	Character font B selected	14 x 24	10 x 24	8 x 24
1	-	-	Undefined			
2	-	-	Undefined			
3	Off	0x00	Bold mode not selected			
	On	0x08	Blod mode selected			
4	Off	0x00	Double-height mode not selected			
	On	0x10	Double-height mode selected			
5	Off	0x00	Double-width mode not selected			
	On	0x20	Double-width mode selected			
6	Off	0x00	Italic mode not selected			
	On	0x40	Italic mode selected			
7	Off	0x00	Underlined mode not selected			
	On	0x80	Underlined mode selected			

- [Notes]
- The device can underline all characters, but cannot underline the spaces set by [0x09](#), [0x1B 0x24](#), [0x1B 0x5C](#) and 90°/270° rotated characters.
 - This command resets the left and right margin at default value (see [0x1D 0x4C](#), [0x1D 0x57](#)).
 - [0x1B 0x45](#) can also be used to turn the bold mode on or off. However, the last-received setting command is the effective one.
 - [0x1B 0x2D](#) can also be used to turn the underlining mode on or off. However, the last-received setting command is the effective one.
 - [0x1D 0x21](#) can also be used to select character height or width. However, the last-received setting command is the effective one.
 - [0x1B 0x34](#) can also be used to turn the italic mode on or off. However, the last-received setting command is the effective one.



• Commands that change the height and width of characters are effective on the x and y axes. In case of 90°/270° rotated characters, command 0x1B 0x21 0x10 selects double-width mode and command 0x1B 0x21 0x20 selects double-height mode.

[Default] n = 0x00

[Reference] 0x1B 0x2D, 0x1B 0x45, 0x1D 0x21, 0x1B 0x34

[Example]

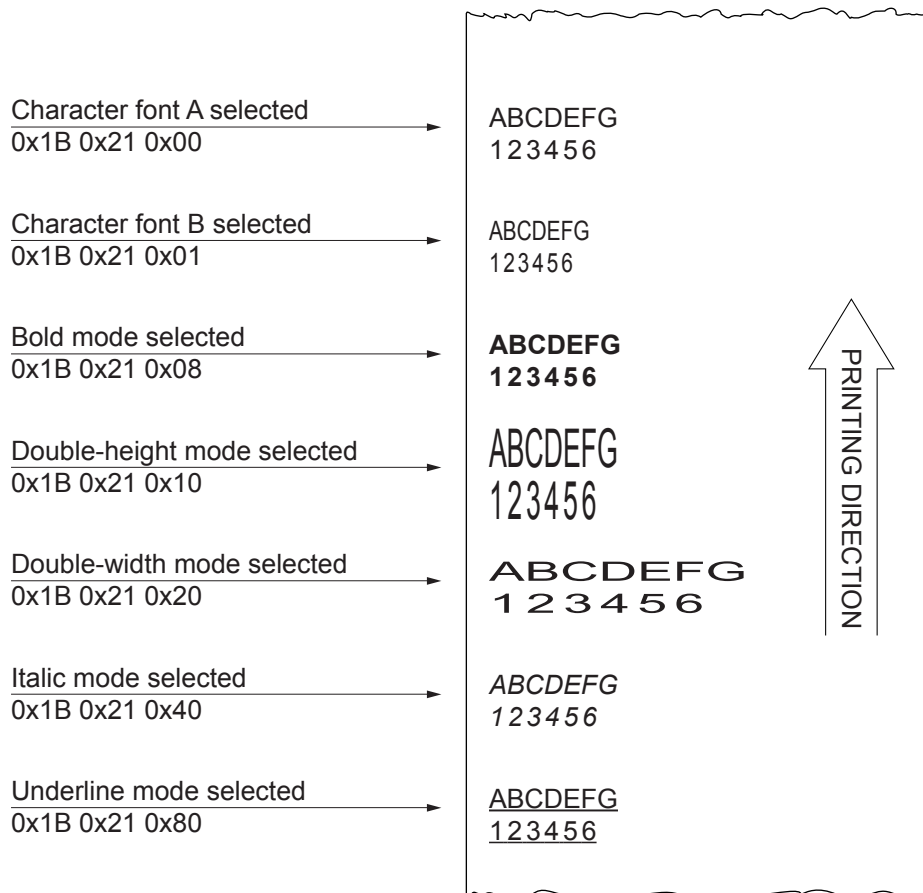



0x1B 0x26

<ESC &>

Defines user-defined characters

Valid for	TG1260HIII TG2460HIII, TG2460HIII EJC TG2480HIII TL60III TL80III						
[Format]	Hex	1B	26	y	c1	cn	x1[d0...dk] ... xn[d0...dk]
	ASCII	ESC	&	y	c1	cn	x1[d0...dk] ... xn[d0...dk]
[Range]	y = 0x03 0x20 ≤ c1 ≤ cn ≤ 0x7E 0x00 ≤ x ≤ 0x12 (font 18 x 24) 0x00 ≤ x ≤ 0x0E (font 14 x 24) 0x00 ≤ x ≤ 0x0A (font 10 x 24) 0x00 ≤ x ≤ 0x08 (font 8 x 24) 0x00 ≤ d0...dk ≤ 0xFF k = cn – c1 + 1						
[Description]	Defines user programmable characters. y specifies the number of bytes in the vertical direction. c1 specifies the start character code and cn specifies the final character code of the characters map area. x specifies the width of the character to be replaced. d0...dk specifies the new character definition.						
[Notes]	<ul style="list-style-type: none"> • It is possible to define multiple characters for consecutive character codes. If only one character is desired, use c1 = cn. • if cn < c1, the command is not executed. • d is the dot data for the characters. The dot pattern is in the horizontal direction starting from the left. Any remaining dots on the right remain blank. • The data to define a user-defined character is (x × y) bytes. • To print a dot, set the corresponding bit to 1; to not have it print, set to 0. • This command can define different user-defined character patterns for each font. To select the font, use 0x1B 0x21. • The user programmable character definitions are cleared when commands 0x1B 0x40 or 0x1D 0x2A are executed or the device is reset or turned off. • x1 [d0 ... dk] will be repeated for each character to be replaced. 						
[Default]	Internal character set						
[Reference]							
[Example]	To replace only the “A” character of the 11 cpi font table (font 18x24), the command sequence is: 0x1B 0x26 0x03 0x41 0x41 0x10 [48 bytes of the new character definition]. To replace “A” and “B” characters of the 11 cpi font table (font 18x24), the command sequence is: 0x1B 0x26 0x03 0x41 0x42 0x10 [48 bytes of the new character definition] 0x10 [48 bytes of the new character definition].						

0x1B 0x2D

<ESC ->

Turn underline mode on or off

Valid for
 TG1260HIII
 TG2460HIII, TG2460HIII EJC
 TG2480HIII
 TL60III
 TL80III

[Format] Hex 1B 2D n
 ASCII ESC - n

[Range] 0x00 ≤ n ≤ 0x02
 0x30 ≤ n ≤ 0x32

[Description] Turns underline mode on or off based on the value of n as follows:

n	FUNCTON
0x00, 0x30	Turns off underline mode
0x01, 0x31	Turns on underline mode (1 dot thick)
0x02, 0x32	Turns on underline mode (2 dot thick)

- [Notes]
- The device can underline all characters, but cannot underline the space and right-side character spacing set by command [0x09](#).
 - The device cannot underline 90°/270° rotated characters and white/black inverted characters.
 - When underline mode is turned off by setting the value of n to 0x00 or 0x30, the data which follows is not underlined.
 - Underline mode can also be turned on or off by using [0x1B 0x21](#). However, the last-received setting command is the effective one.

[Default] n = 0x00

[Reference] [0x1B 0x21](#)

[Example]



0x1B 0x34

<ESC 4>

Turn italic mode on or off

Valid for
 TG1260HIII
 TG2460HIII, TG2460HIII EJC
 TG2480HIII
 TL60III
 TL80III

[Format] Hex 1B 34 n
 ASCII ESC 4 n

[Range] 0x00 ≤ n ≤ 0x01
 0x30 ≤ n ≤ 0x31

[Description] Turns italic mode on or off based on the value of n as follows:

n	FUNCTON
0x00, 0x30	Turns off italic mode
0x01, 0x31	Turns on italic mode

[Notes]

- The device can print any character in italic mode.
- When italic mode is turned off by setting the value of n to 0x00 or 0x30, the data which follows is printed in normal mode.
- Italic mode can also be turned on or off using [0x1B 0x21](#). However, the last-received setting command is the effective one.

[Default] n = 0x00

[Reference] [0x1B 0x21](#)

[Example]

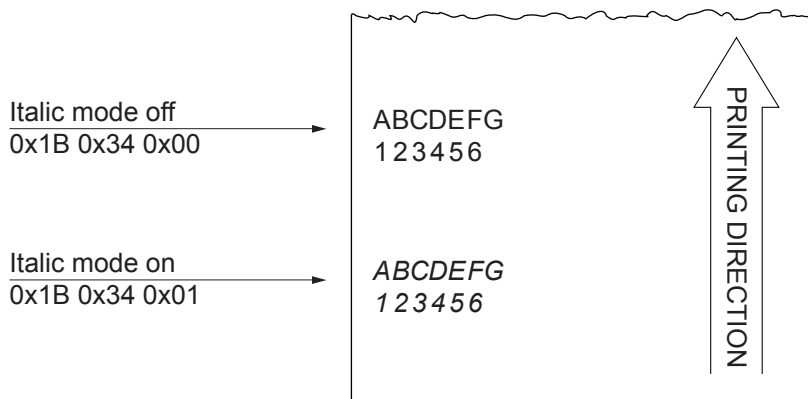

0x1B 0x45

<ESC E>

Turn bold mode on or off

Valid for
 TG1260HIII
 TG2460HIII, TG2460HIII EJC
 TG2480HIII
 TL60III
 TL80III

[Format] Hex 1B 45 n
 ASCII ESC E n

[Range] 0x00 ≤ n ≤ 0xFF

[Description] Turns bold mode on or off, based on the n value:
 - when the Least Significant Bit (LSB) of n is 0, the bold mode is off.
 - when the Least Significant Bit (LSB) of n is 1, the bold mode is on.

[Notes] • Only the Least Significant Bit (LSB) of n is effective.
 • [0x1B 0x21](#) also turns on and off the bold mode. However, the last received command is the effective one.

[Default] n = 0x00

[Reference] [0x1B 0x21](#)

[Example]



0x1B 0x47

<ESC G>

Turn double-strike mode on or off

Valid for
 TG1260HIII
 TG2460HIII, TG2460HIII EJC
 TG2480HIII
 TL60III
 TL80III

[Format] Hex 1B 47 n
 ASCII ESC G n

[Range] 0x00 ≤ n ≤ 0xFF

[Description] Turns double-strike mode on or off, based on the n value:
 - when the Least Significant Bit (LSB) of n is 0, the double-strike mode is off.
 - when the Least Significant Bit (LSB) of n is 1, the double-strike mode is on.

[Notes] • Only the Least Significant Bit (LSB) of n is effective.
 • Device output is the same in double-strike and bold mode.

[Default] n = 0x00

[Reference] [0x1B 0x21](#), [0x1B 0x45](#)

[Example]

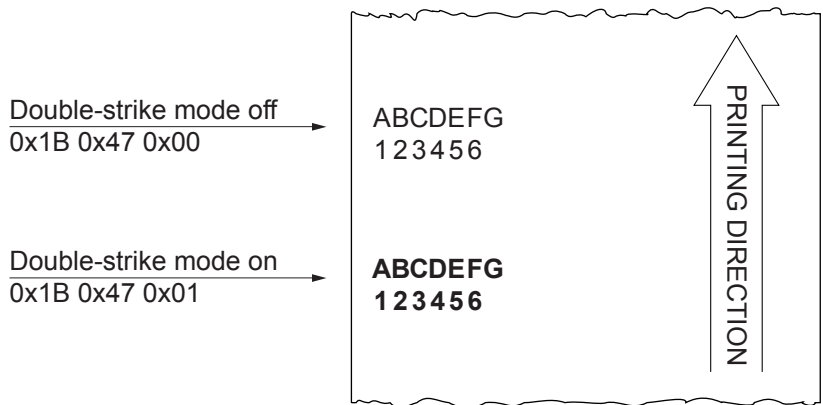



0x1B 0x4D

<ESC M>

Select character font

Valid for TG1260HIII
 TG2460HIII, TG2460HIII EJC
 TG2480HIII
 TL60III
 TL80III

[Format] Hex 1B 4D n
 ASCII ESC M n

[Range] n = 0x00, 0x01, 0x30, 0x31

[Description] Selects characters font depending of cpi value set (Char/Inch) as follows

CHAR/INCH	n	FUNCTION
A = 11 cpi	0x00, 0x30	Font 11 cpi (18x24)
B = 15 cpi	0x01, 0x31	Font 15 cpi (14x24)
A = 15 cpi	0x00, 0x30	Font 15 cpi (14x24)
B = 20 cpi	0x01, 0x31	Font 20 cpi (10x24)
A = 20 cpi	0x00, 0x30	Font 20 cpi (10x24)
B = 25 cpi	0x01, 0x31	Font 25 cpi (8x24)

[Notes]

[Default]

[Reference] [0x1B 0xC1](#)

[Example]



0x1B 0x52

<ESC R>

Select an international character set

Valid for TG1260HIII
 TG2460HIII, TG2460HIII EJC
 TG2480HIII
 TL60III
 TL80III

[Format] Hex 1B 52 n
 ASCII ESC R n

[Range] $0x00 \leq n \leq 0x0A$

[Description] Selects the international character set n according to the table below:

	HEX	23	24	40	5B	5C	5D	5E	60	7B	7C	7D	7E
n	CHARACTER SET												
0x00	U.S.A.	#	\$	@	[\]	^	`	{		}	~
0x01	France	#	\$	à	°	ç	§	^	`	é	ù	è	“
0x02	Germany	#	\$	§	Ä	Ö	Ü	^	`	ä	ö	ü	ß
0x03	United Kingdom	£	\$	@	[\]	^	`	{		}	~
0x04	Denmark I	#	\$	@	Æ	Ø	Å	^	`	æ	ø	å	~
0x05	Sweden	#	¤	É	Ä	Ö	Å	Ü	é	ä	ö	å	ü
0x06	Italy	#	\$	@	°	\	é	^	ù	à	ò	è	ì
0x07	Spain I	Pt	\$	@	i	Ñ	¿	^	`	“	ñ	}	~
0x08	Japan	#	\$	@	[¥]	^	`	{		}	~
0x09	Norway	#	¤	É	Æ	Ø	Å	Ü	é	æ	ø	å	ü
0x0A	Denmark II	#	\$	É	Æ	Ø	Å	Ü	é	æ	ø	å	ü

[Notes]

[Default] n = 0x00

[Reference]

[Example]



0x1B 0x56

<ESC V>

Set 90° rotated print mode

Valid for
 TG1260HIII
 TG2460HIII, TG2460HIII EJC
 TG2480HIII
 TL60III
 TL80III

[Format] Hex 1B 56 n
 ASCII ESC V n

[Range] n = 0x00, 0x01, 0x30, 0x31

[Description] Turns 90° rotation mode on or off based on the value of n as follows:

n	FUNCTION
0x00, 0x30	Disable 90° rotation mode
0x01, 0x31	Enable 90° rotation mode

- [Notes]
- When underlined mode is turned on, the device does not underline 90° rotated characters. All the same it's possible select the underline mode.
 - Double-width and double-height commands in 90° rotation mode enlarge characters in the opposite directions from double-height and double-width commands in normal mode.

Default] n = 0x00

[Reference] 0x1B 0x21, 0x1B 0x2D

[Example]

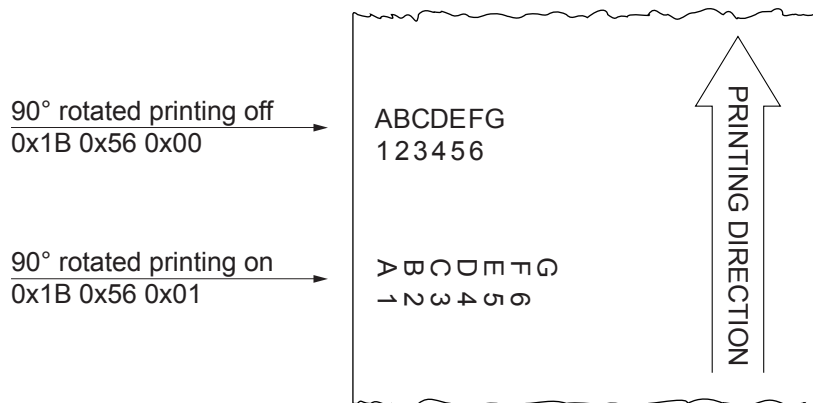



0x1B 0x74

<ESC t>

Select character code table

Valid for TG1260HIII
 TG2460HIII, TG2460HIII EJC
 TG2480HIII
 TL60III
 TL80III

[Format] Hex 1B 74 n
 ASCII ESC t n

[Range] $0x01 \leq n \leq 0x35$, $n = 0xFF$

[Description] Select a page n from the character code table as follows:

n	PAGE
0x00	PC437 - U.S.A., Standard Europe
0x01	Katakana
0x02	PC850 - Multilingual
0x03	PC860 - Portuguese
0x04	PC863 - Canadian/French
0x05	PC865 - Nordic
0x06	VISCII - Vietnamese Standard Code
0x0B	PC851 - Greek on request
0x0C	PC853 - Turkish on request
0x0D	PC857 - Turkish
0x0E	PC737 - Greek
0x0F	ISO8859-7 - Greek on request
0x10	WPC1252 - Scandinavian
0x11	PC866 - Cyrillic 2
0x12	PC852 - Latin 2
0x13	PC858 for Euro symbol in position 0xD5
0x14	KU42 - Thai
0x15	TIS11 - Thai on request
0x1A	TIS18 - Thai on request
0x1E	TCVN_3 - Vietnamese on request
0x1F	TCVN_3 - Vietnamese on request
0x20	PC720 - Arabic on request
0x21	WPC775 - Baltic Rim on request
0x22	PC855 - Cyrillic



n	PAGE
0x23	PC861 - Icelandic on request
0x24	PC862 - Hebrew
0x25	PC864 - Arabic
0x26	PC869 - Greek on request
0x27	ISO8859-2 - Latin 2 on request
0x28	ISO8859-15 - Latin 9 on request
0x29	PC1098 - Farsi
0x2A	PC1118 - Lithuanian on request
0x2B	PC1119 - Lithuanian on request
0x2C	PC1125 - Ukrainian
0x2D	WPC1250 - Latin 2
0x2E	WPC1251 - Cyrillic
0x2F	WPC1253 - Greek
0x30	WPC1254 - Turkish
0x31	WPC1255 - Hebrew
0x32	WPC1256 - Arabic
0x33	WPC1257 - Baltic Rim
0x34	WPC1258 - Vietnamese
0x35	KZ1048 - Kazakh on request
0xFF	Space page

- [Notes]
- PC866 and PC852 tables are valid only for TrueType fonts.
 - The tables are selectable only if the code pages are present on the machine. By selecting a code page not present on the machine, the code page remains the one currently in use.
 - Make sure to select the font type “International” with the command **0x1C 0x25** or with the “Font type” parameter during the setup procedure (refer to the user manual of the device).

[Default] n = 0x00

[Reference] **0x1C 0x25**

[Example] For printing Euro symbol (€), the command sequence is:
0x1B, 0x74, 0x13, 0xD5

0x1B 0x7B

<ESC {>

Turn upside-down printing mode on or off

Valid for
 TG1260HIII
 TG2460HIII, TG2460HIII EJC
 TG2480HIII
 TL60III
 TL80III

[Format] Hex 1B 7B n
 ASCII ESC { n

[Range] $0x00 \leq n \leq 0xFF$

[Description] Turns upside-down printing mode on or off, based on the value of n:
 - when the Least Significant Bit (LSB) of n is 0, the upside-down printing mode is off.
 - when the Least Significant Bit (LSB) of n is 1, the upside-down printing mode is on.

[Notes]

- Only the Least Significant Bit (LSB) of n is effective.
- This command is valid only if entered at the beginning of a line.
- In upside-down printing mode, the device rotates the line to be printed 180° and then prints it.

[Default] n = 0x00

[Reference]

[Example]

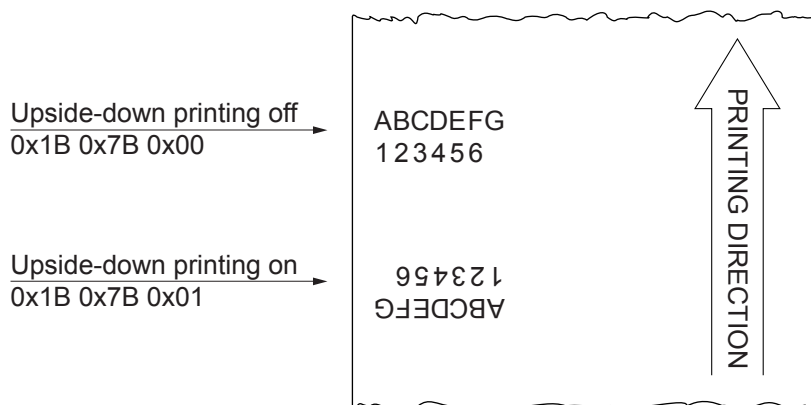

0x1B 0xC1

Select character pitch

Valid for
 TG1260HIII
 TG2460HIII, TG2460HIII EJC
 TG2480HIII
 TL60III
 TL80III

[Format] Hex 1B C1 n
 ASCII ESC 0xC1 n

[Range] 0x00 ≤ n ≤ 0x02
 0x30 ≤ n ≤ 0x32

[Description] This command selects the character pitch expressed in cpi (characters per inch) based on the values of n as follows:

n	PITCH	
0x00, 0x30	Font A = 11 cpi	Font B = 15 cpi
0x01, 0x31	Font A = 15 cpi	Font B = 20 cpi
0x02, 0x32	Font A = 20 cpi	Font B = 25 cpi

[Notes]

[Default] n = 0x00

[Reference] [0x1B 0x21](#)

[Example]

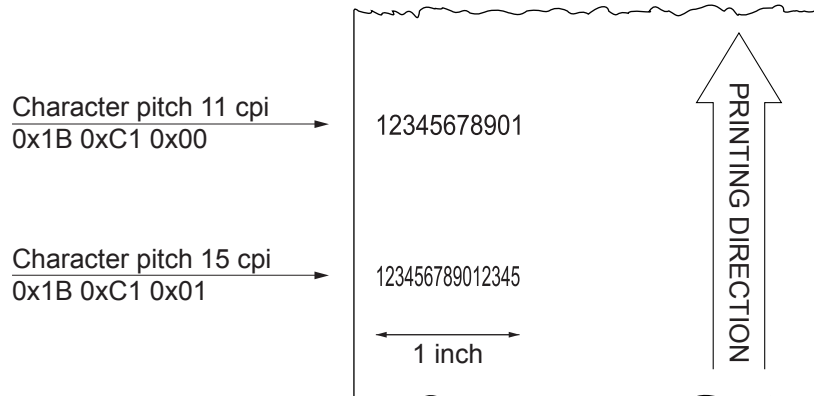



0x1C 0x25

<FS %>

Select the font type

Valid for TG1260HIII
 TG2460HIII, TG2460HIII EJC
 TG2480HIII
 TL60III
 TL80III

[Format] Hex 1C 25 n
 ASCII FS % n

[Range] $0x00 \leq n \leq 0x02$

[Description] Select the font type based on the value of n as follows:

n	FONT TYPE
0x00	International
0x01	Chinese GB18030
0x02	Korean CP949

[Notes]

- The selection made by this command is stored in the RAM memory. Turning off the device reverts to the default value, that can be set with the “Font type” parameter during the setup procedure (refer to the user manual of the device).
- After selecting the font type “International” it must be selected the desired character code table using the command [0x1B 0x74](#).

[Default] n = 0x00

[Reference] [0x1B 0x74](#), see the Chinese fonts management commands manual.

[Example]



0x1D 0x21

<GS !>

Select character size

Valid for	TG1260HIII TG2460HIII, TG2460HIII EJC TG2480HIII TL60III TL80III
-----------	--

[Format]	Hex 1D 21 n ASCII GS ! n
----------	---

[Range]	0x00 ≤ n ≤ 0x07 0x10 ≤ n ≤ 0x17 0x20 ≤ n ≤ 0x27 0x30 ≤ n ≤ 0x37 0x40 ≤ n ≤ 0x47 0x50 ≤ n ≤ 0x57 0x60 ≤ n ≤ 0x67 0x70 ≤ n ≤ 0x77
---------	--

[Description] Selects character height and width, as follows:

- Bits 0 to 3: to select character height (see table 2).
- Bits 4 to 7: to select character width (see table 1).

Table 1 Select character width

HEX	WIDTH
00	1 (normal)
10	2 (width = 2x)
20	3 (width = 3x)
30	4 (width = 4x)
40	5 (width = 5x)
50	6 (width = 6x)
60	7 (width = 7x)
70	8 (width = 8x)

Table 2 Select character height

HEX	HEIGHT
00	1 (normal)
01	2 (height = 2x)
02	3 (height = 3x)
03	4 (height = 4x)
04	5 (height = 5x)
05	6 (height = 6x)
06	7 (height = 7x)
07	8 (height = 8x)

[Notes]

- This command is effective for all characters (except HRI characters).
- If n falls outside the defined range, this command is ignored.
- Characters enlarged to different heights on the same line are aligned at the baseline or top line.
- **0x1B 0x21** can also be used to select character size. However, the setting of the last received command is the effective one.
- This command is effective on the x and y axes. In case of 90°/270° rotated characters, bit from 0 to 3 select character width and bit from 4 to 7 select character height.



[Default] n = 0x00

[Reference] 0x1B 0x21

[Example] For printing a character with 6x width and height the command sequence is:
0x1D 0x21 0x55

0x1D 0x42

<GS B>

Turn black and white reverse printing mode on or off

Valid for
 TG1260HIII
 TG2460HIII, TG2460HIII EJC
 TG2480HIII
 TL60III
 TL80III

[Format] Hex 1D 42 n
 ASCII GS B n

[Range] 0x00 ≤ n ≤ 0xFF

[Description] Turns black and white reverse printing mode on or off, based on the value of n:
 - when the Least Significant Bit (LSB) of n is 0, white/black reverse printing is turned off.
 - when the Least Significant Bit (LSB) of n is 1, white/black reverse printing is turned on.

- [Notes]
- Only the Least Significant Bit (LSB) of n is effective.
 - This command is available for both built-in and user-defined characters.
 - This command does not affect bit image, downloaded bit image, barcode, HRI characters and spacing skipped by 0x09, 0x1B 0x24 and 0x1B 0x5C.
 - This command does not affect white space between lines.
 - White/black reverse mode has a higher priority than underline mode. Even if underline mode is on, it will be disabled (but not cancelled) when black and white reverse mode is selected.

[Default] n = 0x00

[Reference]

[Example]

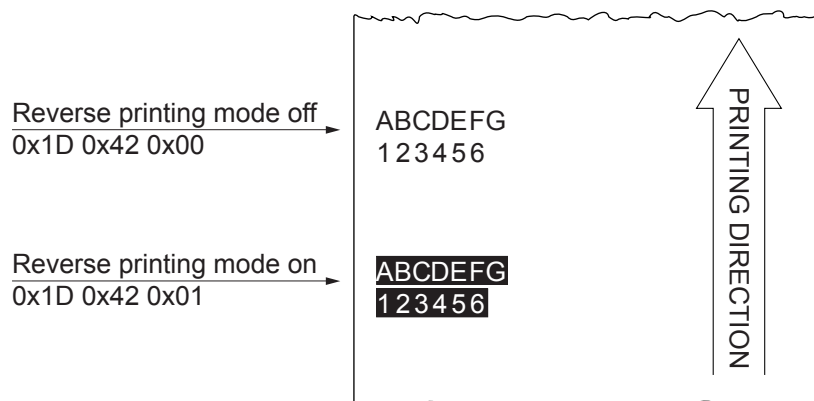

LINE SPACING COMMANDS

0x1B 0x30

<ESC 0>

Select 1/8-inch line spacing

Valid for TG1260HIII
 TG2460HIII, TG2460HIII EJC
 TG2480HIII
 TL60III
 TL80III

[Format] Hex 1B 30
 ASCII ESC 0

[Range]

[Description] Selects 1/8-inch line spacing.

[Notes]

[Default]

[Reference] [0x1B 0x32](#), [0x1B 0x33](#)

[Example]



0x1B 0x32

<ESC 2>

Select 1/6-inch line spacing

Valid for	TG1260HIII
	TG2460HIII, TG2460HIII EJC
	TG2480HIII
	TL60III
	TL80III

[Format]	Hex	1B	32
	ASCII	ESC	2

[Range]

[Description] Selects 1/6-inch line spacing.

[Notes]

[Default]

[Reference] [0x1B 0x30](#), [0x1B 0x33](#)

[Example]

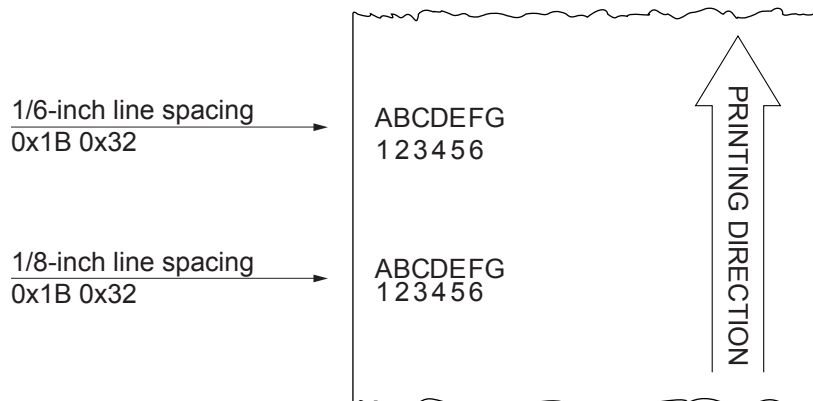



0x1B 0x33

<ESC 3>

Set line spacing

Valid for	TG1260HIII TG2460HIII, TG2460HIII EJC TG2480HIII TL60III TL80III
[Format]	Hex 1B 33 n ASCII ESC 3 n
[Range]	0x00 ≤ n ≤ 0xFF
[Description]	Sets line spacing to [n × (vertical or horizontal motion unit)].
[Notes]	<ul style="list-style-type: none">• The horizontal and vertical motion unit are specified by 0x1D 0x50. Changing the horizontal or vertical motion unit does not affect the current line spacing.• The 0x1D 0x50 command can change the horizontal (and vertical) motion unit. However, the value cannot be less than the minimum vertical movement amount.• In standard mode, the vertical motion unit is used.• The maximum spacing is 32.5 mm.
[Default]	n = 0x40 (1/6 inch)
[Reference]	0x1B 0x30 , 0x1B 0x32 , 0x1D 0x50
[Example]	

PRINT COMMANDS

0x0A

<LF>

Print and line feed

Valid for	TG1260HIII
	TG2460HIII, TG2460HIII EJC
	TG2480HIII
	TL60III
	TL80III

[Format]	Hex	0A
	ASCII	LF

[Range]

[Description] This command sets the print position to the beginning of the line printing the data in the buffer and feeding one line based on the line spacing set with the command [0x1B 0x30](#) or [0x1B 0x32](#).

[Notes] If the buffer is empty, the printing feeds of a value equal to the sum of the character height and line spacing.

[Default] 1/6-inch (32 dots)

[Reference] [0x1B 0x30](#), [0x1B 0x32](#), [0x1B 0x33](#), [0x0D](#)

[Example]

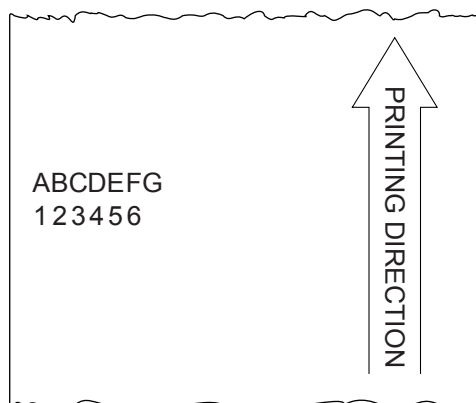

To print the ticket shown in figure the command sequence is:
 ABCDEFG 0x0A 123456 0x0A

0x0D

<CR>

Print and carriage return

Valid for	TG1260HIII TG2460HIII, TG2460HIII EJC TG2480HIII TL60III TL80III
-----------	--

[Format] Hex 0D
 ASCII CR

[Range]

[Description] This command handles the end of a line text.

[Notes] If “Autofeed” setup parameter is set to “CR enabled”, this command works in the same way as 0x0A, otherwise it is disregarded.

[Default] See “Autofeed” setup parameter (refer to the user manual of the device).

[Reference] 0x0A

[Example]

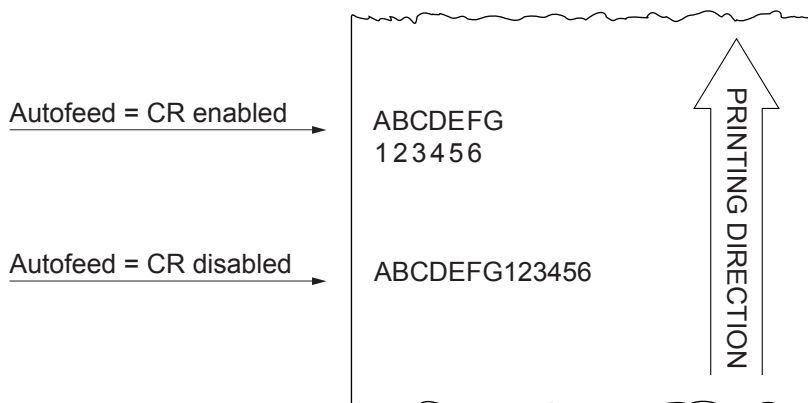

To print the ticket shown in figure the command sequence is:
ABCDEF 0x0D 123456 0x0D



0x1B 0x4A

<ESC J>

Print and paper feed

Valid for	TG1260HIII TG2460HIII, TG2460HIII EJC TG2480HIII TL60III TL80III
-----------	--

[Format]	Hex 1B 4A n ASCII ESC J n
[Range]	0x00 ≤ n ≤ 0xFF
[Description]	Prints the data saved in the print buffer and feeds the paper [n × vertical or horizontal motion unit].
[Notes]	<ul style="list-style-type: none">• After printing has been completed, this command sets the print starting position to the beginning of the line.• The paper feed amount set by this command does not affect the values set by 0x1B 0x32 or 0x1B 0x33.• The horizontal and vertical motion units are specified by 0x1D 0x50.• 0x1D 0x50 can change the vertical (and horizontal) motion unit. However, the value cannot be less than the minimum vertical movement amount.• In standard mode, the vertical motion unit is used.
[Default]	
[Reference]	0x1D 0x50
[Example]	



0x1B 0x64

<ESC d>

Print and feed paper n lines

Valid for	TG1260HIII TG2460HIII, TG2460HIII EJC TG2480HIII TL60III TL80III
-----------	--

[Format]	Hex 1B 64 n ASCII ESC d n
[Range]	0x00 ≤ n ≤ 0xFF
[Description]	Prints the data saved in the print buffer and feeds the paper n lines.
[Notes]	<ul style="list-style-type: none">• n rows paper feed is equivalent to (n × char height + line spacing set).• Sets the print starting position at the beginning of the line.• This command does not affect the line spacing set by 0x1B 0x32 or 0x1B 0x33.• The maximum paper feed amount is 254 lines. Even if a paper feed amount of more than 254 lines is set, the device feeds the paper only 254 lines.
[Default]	
[Reference]	0x1B 0x32 , 0x1B 0x33
[Example]	



0x1C 0x82

Print date

Valid for	TG1260HIII
	TG2460HIII, TG2460HIII EJC
	TG2480HIII
	TL60III
	TL80III

[Format]	Hex	1C	82
	ASCII	FS	0x82

[Range]

[Description] Prints date in the format specified by the command [0x1C 0x84](#) with the parameter n = 0x44.

- [Notes]
- The clock works only with the device switched on. If the device is turned off, the clock stops.
 - It is necessary to initialize date and time to every device init.

[Default] “dd/mm/yy”

[Reference] [0x1C 0x83](#), [0x1C 0x84](#)

[Example]



0x1C 0x83

Print time

Valid for	TG1260HIII TG2460HIII, TG2460HIII EJC TG2480HIII TL60III TL80III
-----------	--

[Format]	Hex	1C	83
	ASCII	FS	0x83

[Range]

[Description] Prints time in the format specified by the command [0x1C 0x84](#) with the parameter n = 0x54.

[Notes]

- The clock works only with the device switched on. If the device is turned off, the clock stops.
- It is necessary to initialize date and time to every device init.

[Default] “hh:mm:ss”

[Reference] [0x1C 0x82](#), [0x1C 0x84](#)

[Example]

0x1D 0x7C

<GS |>

Set printing density

Valid for TG1260HIII
 TG2460HIII, TG2460HIII EJC
 TG2480HIII
 TL60III
 TL80III

[Format] Hex 1D 7C n
 ASCII GS | n

[Range] $0x02 \leq n \leq 0x06$
 $0x32 \leq n \leq 0x36$

[Description] Sets printing density. n specifies printing density as follows:

n	PRINTING DENSITY
0x02, 0x32	- 25%
0x03, 0x33	- 12.5%
0x04, 0x34	0%
0x05, 0x35	+ 12.5%
0x06, 0x36	+ 25%

[Notes] Printing density reverts to the default value when the device is reset or turned off.

[Default] n = 0x04

[Reference]

[Example]

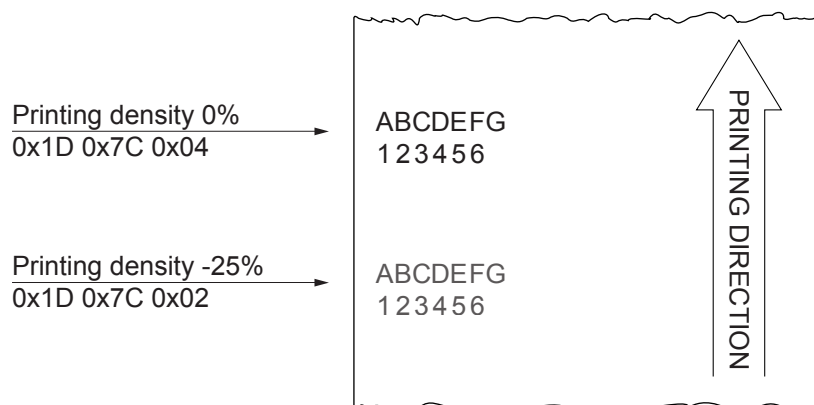



STATUS COMMANDS

0x10 0x04

<DLE EOT>

Real-time status transmission

Valid for	TG1260HIII TG2460HIII, TG2460HIII EJC TG2480HIII TL60III TL80III
-----------	--

[Format]	Hex 10 04 n ASCII DLE EOT n
----------	---

[Range]	0x01 ≤ n ≤ 0x04 n = 0x11, 0x14, 0x15
---------	---

[Description] Transmits the selected status when this command is received. The status to be transmitted is indicated in the following table:

n = 0x01	transmits device status
n = 0x02	transmits off-line status
n = 0x03	transmits error status
n = 0x04	transmits paper roll sensor status
n = 0x11	transmits print status
n = 0x14	transmits full status
n = 0x15	transmits device ID

Device status (n = 0x01)

BIT	OFF/ON	HEX	FUNCTION
0	Off	00	Not used. Fixed to off
1	On	02	Not used. Fixed to on
2	-	-	RESERVED
3	Off	00	On-line
	On	08	Off-line
4	On	10	Not used. Fixed to on
5	-	-	RESERVED
6	-	-	RESERVED
7	Off	00	LF key released
	On	80	LF key pressed



Off-line status (n = 0x02)

BIT	OFF/ON	HEX	FUNCTION
0	Off	00	Not used. Fixed to off
1	On	02	Not used. Fixed to on
2	Off	00	Cover closed
	On	04	Cover opened
3	Off	00	Paper isn't fed by FEED key
	On	08	Paper is fed by FEED key
4	On	10	Not used. Fixed to on
5	Off	00	Paper present
	On	20	Printing stop due to paper end
6	Off	00	No error
	On	40	Error
7	Off	00	Not used. Fixed to off

Error status (n = 0x03)

BIT	OFF/ON	HEX	FUNCTION
0	Off	00	Not used. Fixed to off
1	On	02	Not used. Fixed to on
2	-	-	RESERVED
3	Off	00	Autocutter ok
	On	08	Autocutter error
4	On	10	Not used. Fixed to on
5	Off	00	No unrecoverable error
	On	20	Unrecoverable error
6	Off	00	No auto-recoverable error
	On	40	Auto-recoverable error
7	Off	00	Not used. Fixed to off



Paper roll sensor status (n = 0x04)

BIT	OFF/ON	HEX	FUNCTION
0	Off	00	Not used. Fixed to off
1	On	02	Not used. Fixed to on
2, 3	Off	00	Paper present
	On	0C	Low paper
4	On	10	Not used. Fixed to on
5, 6	Off	00	Paper present
	On	60	Paper not present
7	Off	00	Not used. Fixed to off

Print status (n = 0x11)

BIT	OFF/ON	HEX	FUNCTION
0	Off	00	Not used. Fixed to off
1	On	02	Not used. Fixed to on
2	Off	00	Paper drag motor off
	On	04	Paper drag motor on
3	-	-	RESERVED
4	On	10	Not used. Fixed to on
5	Off	00	Paper present
	On	20	Printing stopped out for paper end
6	-	-	RESERVED
7	Off	00	Not used. Fixed to off

Full status (n = 0x14, 6 bytes)

1st byte = 0x10 (DLE)

2nd byte = 0x0F



3rd byte = Paper status

BIT	OFF/ON	HEX	FUNCTION
0	Off	00	Paper present
	On	01	Paper not present
1	-	-	RESERVED
2	Off	00	Paper present
	On	04	Low paper
3	-	-	RESERVED
4	-	-	RESERVED
5	Off	00	Ticket not present in output
	On	20	Ticket present in output
6	Off	00	Paper virtually present *
	On	40	Virtual paper end *
7	Off	00	Black mark is placed over the sensor
	On	80	Black mark is not placed over the sensor

(*) Paper virtually present is set when the paper length available, read by `0x1D 0xE1`, is 0.

4th byte = User status

BIT	OFF/ON	HEX	FUNCTION
0	Off	00	No error, printing head down
	On	01	Printing head up error
1	Off	00	Cover closed
	On	02	Cover opened
2	Off	00	No spooling
	On	04	Spooling
3	Off	00	Drag paper motor off
	On	08	Drag paper motor on
4	-	-	RESERVED
5	Off	00	LF key released
	On	20	LF key pressed
6	Off	00	FF key released
	On	40	FF key pressed
7	-	-	RESERVED



5th byte = Recoverable status error

BIT	OFF/ON	HEX	FUNCTION
0	Off	00	Head temperature ok
	On	01	Head temperature error
1	Off	00	No COM error
	On	02	RS232 COM error
2	-	-	RESERVED
3	Off	00	Power supply voltage ok
	On	08	Power supply voltage error
4	-	-	RESERVED
5	Off	00	Acknowledge command
	On	20	Not acknowledge command error
6	Off	00	Free paper path
	On	40	Paper jam
7	Off	00	Black mark search ok
	On	80	Error in black mark search

6th byte = Unrecoverable error status

BIT	OFF/ON	HEX	FUNCTION
0	Off	00	Autocutter ok
	On	01	Autocutter error
1	Off	00	Autocutter cover ok
	On	02	Autocutter cover open
2	Off	00	RAM ok
	On	04	RAM error
3	Off	00	EEPROM ok
	On	08	EEPROM error
4	-	-	RESERVED
5	-	-	RESERVED
6	-	-	RESERVED
7	-	-	RESERVED



Transmit device ID (n = 0x15)

1st byte = (refer to command [0x1D 0x49](#))

[Notes] This command is immediately executed even when the data buffer is full.

[Default]

[Reference]

[Example] Request for device status transmission:

0x10 0x04 0x01

Device response:

0x80 LF key pressed



0x1C 0xEA

Transmit the device serial number

Valid for	TG1260HIII TG2460HIII, TG2460HIII EJC TG2480HIII TL60III TL80III
-----------	--

[Format]	Hex 1C EA n ASCII FS 0xEA n
----------	---

[Range] n = 0x52, 0x72

[Description] Transmits the device serial number.

- [Notes]
- The serial number is a string of 16 alphanumeric characters.
 - If the printer serial number is not defined, the device returns a string of 16 characters with a value of 0x00.

[Default]

[Reference]

[Example] To read the device serial number the command sequence is:
0x1C 0xEA 0x52

The device returns a string of 16 alphanumeric characters just like the following:
'ABC0123456789012'



0x1D 0x72

<GS r>

Transmit status

Valid for TG1260HIII
TG2460HIII, TG2460HIII EJC
TG2480HIII
TL60III
TL80III

[Format] Hex 1D 72 n
ASCII GS r n

[Range] n = 0x01, 0x31

[Description] Transmits paper sensor status.

[Notes] This command is executed when the data is processed in the data buffer. Therefore, there may be a time lag between receiving the command and transmitting the status, depending on data buffer status.

[Default]

[Reference] [0x10 0x04](#)

[Example]



0x1D 0xE0

Enable or disable automatic FULL STATUS BACK

Valid for	TG1260HIII TG2460HIII, TG2460HIII EJC TG2480HIII TL60III TL80III
-----------	--

[Format]	Hex 1D E0 n ASCII GS 0xE0 n
----------	--

[Range] 0x00 ≤ n ≤ 0xFF

[Description] Enable or disable automatic full status back. n specifies the composition of full status as follows:

BIT	OFF/ON	HEX	FUNCTION
0	Off	00	Disable paper status
	On	01	Enable paper status
1	Off	00	Disable user status
	On	02	Enable user status
2	Off	00	Disable recoverable error status
	On	04	Enable recoverable error status
3	Off	00	Disable unrecoverable error status
	On	08	Enable unrecoverable error status
4	-	-	Undefined
5	-	-	Undefined
6	-	-	Undefined
7	-	-	Undefined

[Notes] Once enable at least one byte of the full status, for each change of at least one of the bits which compose the required status, the status sent in automatic from the device will be so composed as follows:

1st Byte = 0x10 (DLE=
2nd Byte = n

[Default]

[Reference] [0x10 0x04](#)

[Example]



0x1D 0xE1

Reading of length paper available before virtual paper-end

Valid for

- TG1260HIII
- TG2460HIII, TG2460HIII EJC
- TG2480HIII
- TL60III
- TL80III

[Format]

Hex	1D	E1
ASCII	GS	0xE1

[Range]

[Description]

Reading of length paper available before virtual paper-end (expressed in centimetres).
The command return a string pointing out how much paper is available.

[Notes]

- The length of residual paper reported is just as an indication because tolerances and other factors are not taken into consideration (paper thickness, roll core diameter, roll core thickness).
- To set virtual paper-end limit, measure the length of the paper from low paper to the end of the roll, using several of them.

[Default]

[Reference]

[Example]

If there are 5.1 m before paper end, the answer will be:
'510cm'



0x1D 0xE2

Reading number of cuts performed by the autocutter

Valid for	TG1260HIII
	TG2460HIII, TG2460HIII EJC
	TG2480HIII
	TL60III
	TL80III

[Format]	Hex	1D	E2
	ASCII	GS	0xE2

[Range]

[Description] Reading the number of cuts performed by the autocutter.

[Notes] The command returns a string indicating how many cuts are performed by the autocutter.

[Default]

[Reference]

[Example] If the autocutter has performed 785 cuts, the answer will be:
'785cuts'



0x1D 0xE3

Reading of length of printed paper

Valid for

- TG1260HIII
- TG2460HIII, TG2460HIII EJC
- TG2480HIII
- TL60III
- TL80III

[Format]

Hex	1D	E3
ASCII	GS	0xE3

[Range]

[Description] Reading of length expressed in centimetre of printed paper.

[Notes] The command returns a string indicating how much paper is printed.

[Default]

[Reference]

[Example] If the device has printed about 388.9 m, the answer will be:
'38890cm'



0x1D 0xE5

Reading number of power up

Valid for	TG1260HIII
	TG2460HIII, TG2460HIII EJC
	TG2480HIII
	TL60III
	TL80III

[Format]	Hex	1D	E5
	ASCII	GS	0xE5

[Range]

[Description] Reading number of power up of the device.

[Notes] The command returns a string indicating the number of device power ups.

[Default]

[Reference]

[Example] If the device is turned on 512 times, the answer will be:
'512on'



BIT-IMAGE COMMANDS

0x1B 0x2A

<ESC *>

Select bit image mode

Valid for	TG1260HIII TG2460HIII, TG2460HIII EJC TG2480HIII TL60III TL80III
-----------	--

[Format]	Hex 1B 2A m nL nH d1...dk ASCII ESC * m nL nH d1...dk
----------	--

[Range]	m = 0x00, 0x01, 0x20, 0x21 0x00 ≤ nL ≤ 0xFF 0x00 ≤ nH ≤ 0x03 0x00 ≤ d ≤ 0xFF
---------	---

[Description] Selects a bit image mode using m for the number of dots specified by nL and nH, as follows:

m	MODE	VERTICAL DIRECTION		HORIZONTAL DIRECTION	
		N. DOTS	DPI	DPI	N. DATA (k)
0x00	8 dots single density	8	67	100	nL + nH × 256
0x01	8 dots double density	8	67	200	nL + nH × 256
0x20	24 dots single density	24	200	100	(nL + nH × 256) × 3
0x21	24 dots double density	24	200	200	(nL + nH × 256) × 3

- [Notes]
- The nL and nH commands indicate the number of dots of the bit image in the horizontal direction. The number of dots is calculated using: nL + nH × 256.
 - If the bit image data input exceeds the number of dots to be printed on a line, the excess data is ignored.
 - d indicates the bit image data. Set a corresponding bit to 1 to print a dot, or to 0 to not print the dot.
 - If the value of m is outside the specified range, nL and data following it are processed as normal data.
 - If the width of the printing area set by 0x1D 0x4C and 0x1D 0x57 is less than the width required by the data set using 0x1B 0x2A, the excess data are ignored.
 - To print the bit image use 0x0A, 0x0D, 0x1B 0x4A or 0x1B 0x64.
 - After printing a bit image, the device returns to normal data processing mode.
 - This command is not affected by the bold, double-strike, underline (etc.) print modes, except for the upside-down mode.

- The relationship between the image data and the dots to be printed is as follows:

8-dot bit image

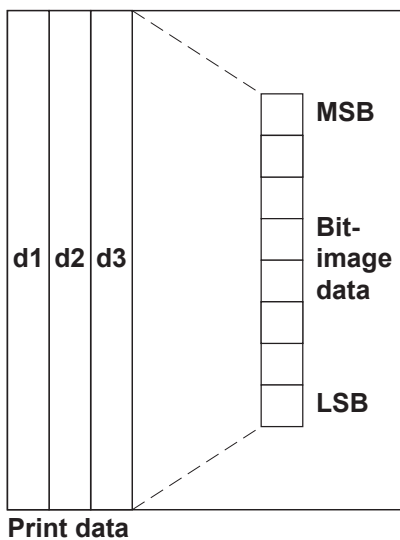

24-dot bit image

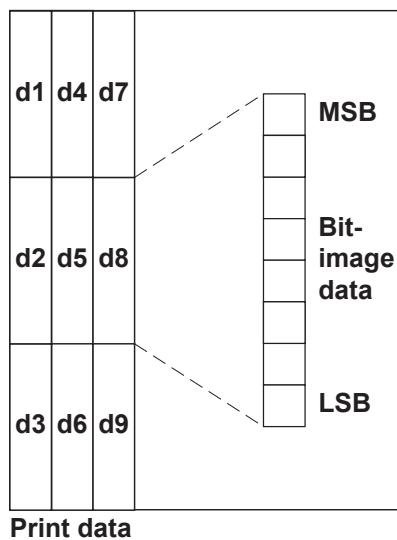

[Default]

[Reference]

[Example]

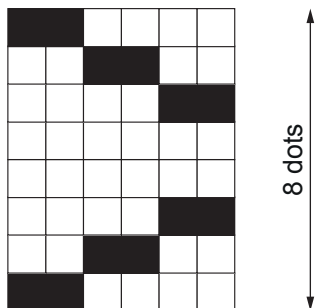

8 dots single density

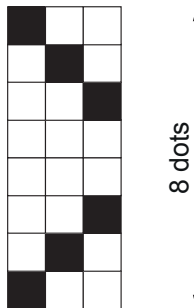

8 dots double density

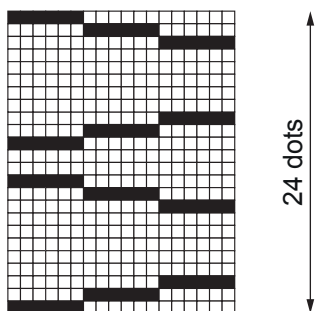

24 dots single density

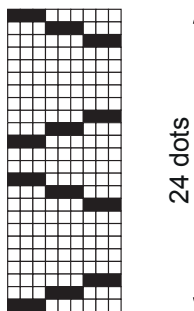

24 dots double density

0x1C 0x70

<FS p>

Print NV bit image

Valid for
 TG1260HIII
 TG2460HIII, TG2460HIII EJC
 TG2480HIII
 TL60III
 TL80III

[Format] Hex 1C 70 n m
 ASCII FS p n m

[Range] 0x01 ≤ n ≤ 0xFF
 0x00 ≤ m ≤ 0x03
 0x30 ≤ m ≤ 0x33

[Description] Prints a NV bit image n using the mode specified by m:

m	MODE
0x00, 0x30	Normal
0x01, 0x31	Double width
0x02, 0x32	Double height
0x03, 0x33	Quadruple

- n is the number of the NV bit image

[Notes]

- NV bit image means a bit image which is defined in a non-volatile memory by [0x1C 0x71](#) and printed by [0x1C 0x70](#).
- This command is not effective when the specified NV bit image has not been defined.
- In standard mode, this command is effective only when there is no data in the print buffer.
- This command is not affected by print modes (bold, underline, character size, white/black reverse printing, etc.), except upside-down printing mode.
- If the printing area width set by [0x1D 0x4C](#) and [0x1D 0x57](#) for the NV bit image is less than one vertical line, the following processing is executed only on the line in question. However, in NV bit image mode, one vertical line means 1 dot (one half dot for slip paper) in normal mode (m = 0x00, 0x30) and in double-height mode (m = 0x02, 0x32), and it means 2 dots (two half dots for slip paper) in double-width mode (m = 0x01, 0x31) and in quadruple mode (m = 0x03, 0x33).
- The printing area width is extended to the right in NV bit image mode up to one line vertically. In this case, printing does not exceed the printable area.
- If the printing area width cannot be extended by one line vertically, the left margin is reduced to accommodate one line vertically.
- If the downloaded bit image to be printed exceeds one line, the excess data is not printed.
- This command feeds dots (for the height n of the NV bit image) in normal and double-width modes, and (for the height n x 2 of the VN bit image) in double-height and quadruple modes, regardless of the line spacing specified by [0x1B 0x32](#) or [0x1B 0x33](#).
- After printing the bit image, this command sets the print position to the beginning of the line and processes the data that follows as normal data.



[Default]

[Reference] 0x1C 0x71

[Example]



0x1C 0x71

<FS q>

Define NV bit image

Valid for	TG1260HIII TG2460HIII, TG2460HIII EJC TG2480HIII TL60III TL80III				
[Format]	Hex	1C	71	n	[xL xH yL yH d1...dk] 1...[xL xH yL yH d1...dk] n
	ASCII	FS	q	n	[xL xH yL yH d1...dk] 1...[xL xH yL yH d1...dk] n
[Range]	$0x01 \leq n \leq 0xFF$ $0x00 \leq xL \leq 0xFF$ $0x00 \leq xH \leq 0x03$ (when $1 \leq (xL + xH \times 256) \leq 1023$) $0x00 \leq yL \leq 0x01$ (when $1 \leq (yL + yH \times 256) \leq 288$) $0x00 \leq d \leq 0xFF$ $k = (xL + xH \times 256) \times (yL + yH \times 256) \times 8$ Total defined data area = 3 MB				
[Description]	Define the NV bit image specified by n. <ul style="list-style-type: none"> n specifies the number of the defined NV bit image. xL, xH specifies $(xL + xH \times 256) \times 8$ dots in the horizontal direction for the NV bit image you are defining. yL, yH specifies $(yL + yH \times 256) \times 8$ dots in the vertical direction for the NV bit image you are defining. 				
[Notes]	<ul style="list-style-type: none"> Frequent write command execution may cause damage the NV memory. Therefore, it is recommended to write the least possible in the memory and no more than 10 times per day. This command cancels all NV bit images that have already been defined by this command. The device can not redefine only one of several data definitions previously defined. In this case, all data needs to be sent again. NV bit image means a bit image which is defined in a non-volatile memory by 0x1C 0x71 and printed by 0x1C 0x70. When the amount of data exceeds the capacity left in the range defined by xL, xH, yL, yH, the device processes xL, xH, yL, yH out of the defined range. In the first group of NV bit images, when any of the parameters xL, xH, yL, yH is out of the definition range, this command is disabled. In groups of NV bit images other than the first one, when the device processes xL, xH, yL, yH out of the defined range, it stops processing this command and starts writing into the non-volatile images. At this time, NV bit images that haven't been defined are disabled (undefined), but any NV bit images before that are enabled. The d indicates the definition data. In data (d) a 1 bit specifies a dot to be printed and a 0 bit specifies a dot not to be printed. This command defines n as the number of a NV bit image. Numbers rise in order from NV bit image 01H. Therefore, the first data group [xL xH yL yH d1...dk] is NV bit image 01H, and the last data group [xL xH yL yH d1...dk] is NV bit image n. The total agrees with the number of NV bit images specified by command 0x1C 0x70. A definition data of a NV bit image consists of [xL xH yL yH d1...dk]. Therefore, when only one NV bit image is defined, $n = 0x01$. 				

- The device processes a data group [xL xH yL yH d1...dk] once.
- The device uses $([\text{data: } (xL + xH \times 256) \times (yL + yH \times 256) \times 8] + [\text{header :4}])$ bytes of non-volatile memory.
- The definition area in this device is a maximum of 3 MB. This command can define several NV bit images, but cannot define a bit image data whose total capacity [bit image data + header] exceeds 3 MB.
- When this command is received during macro definition, the device ends macro definition, and begins executing this command.
- Once a NV bit image is defined, it is not erased by executing **0x1B 0x40**, reset, and power off.
- This command executes only definition of a NV bit image and does not execute printing. Printing of the NV bit image is executed by the **0x1C 0x70** command.

[Default]

[Reference] **0x1C 0x70**

[Example] To make a image or logo of width = 512 dots and height = 768 dots the command sequence to send is:
0x1C 0x71 0x01 0x40 0x00 0x60 0x00 followed by 49152 bytes which define the image as the following drawing:

When xL = 64, xH = 0,
 yL = 96, yH = 0

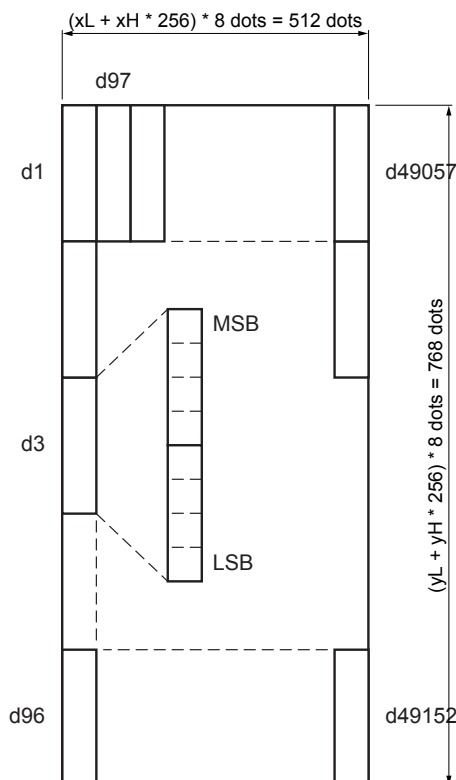



0x1D 0x2A

<GS *>

Logo storage

Valid for

TG1260HIII
 TG2460HIII, TG2460HIII EJC
 TG2480HIII
 TL60III
 TL80III

[Format]

Hex	1D	2A	m	d1...dk
ASCII	GS	*	m	d1...dk

[Range]

m = 0x00, 0x01
 0x00 ≤ d ≤ 0xFF

[Description]

Stores a logo in the flash bank specified by m as follows:

m	FUNCTION
0x00	Save logo in the flash bank 1
0x01	Save logo in the flash bank 2

[Notes]

- The stored logo is a “.bmp” image in Windows bitmap format; a monochrome image (1 bit/pixel) must be used.
- The maximum size allowed for the “.bmp” image is 32 kB.
- d indicates the byte of the “.bmp” image.
- If the value of m is outside the specified range, the data following it are processed as normal data.

[Default]

[Reference]

[Example]

0x1D 0x70

<GS p>

Print logo

Valid for TG1260HIII
 TG2460HIII, TG2460HIII EJC
 TG2480HIII
 TL60III
 TL80III

[Format] Hex 1D 70 m n
 ASCII GS p m n

[Range] $0x00 \leq m \leq 0x03$ (Logo number)
 n = 0x00, 0x01, 0x02, 0x03

[Description] The bit image specified by m (if stored in flash memory) is printed in the mode indicated by n as described in the following table:

n	PRINT MODE
0x00	Normal
0x01	Double width
0x02	Double height
0x03	Double width and double height

[Notes]

[Default]

[Reference]

[Example] n = 0x00

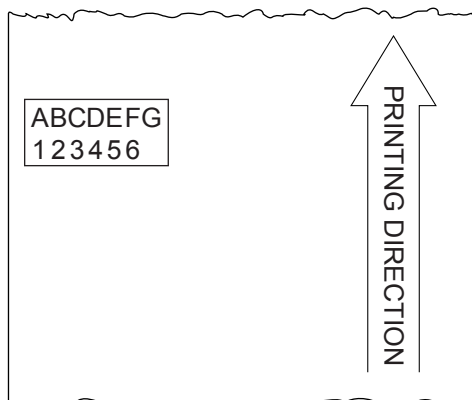



n = 0x01: Double width

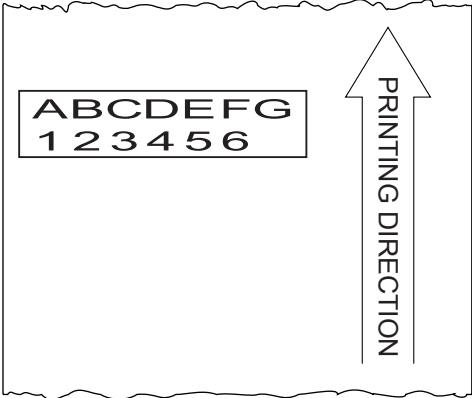

n = 0x02: Double height

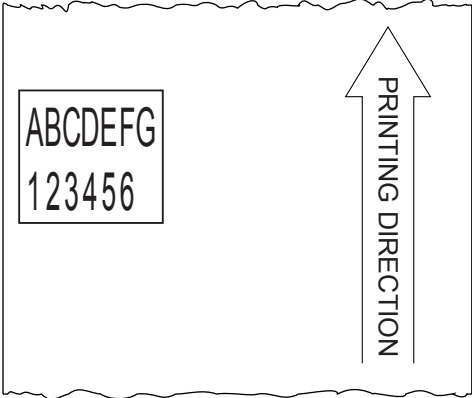

n = 0x03: Double width and double height

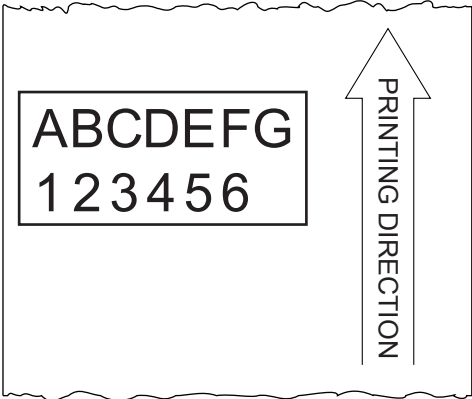



PRINT POSITION COMMANDS

0x08

<BS>

Back space

Valid for	TG1260HIII
	TG2460HIII, TG2460HIII EJC
	TG2480HIII
	TL60III
	TL80III

[Format]	Hex	08
	ASCII	BS

[Range]

[Description] Moves print position to previous character.

[Notes] This command can be used to put two characters at the same position.

[Default]

[Reference]

[Example]

0x09

<HT>

Horizontal tab

Valid for	TG1260HIII TG2460HIII, TG2460HIII EJC TG2480HIII TL60III TL80III
-----------	--

[Format]	Hex 09 ASCII HT
----------	--

[Range]

[Description] Moves the print position to the next horizontal tab position.

- [Notes]
- Horizontal tab position are set using [0x1B 0x44](#).
 - Ignored unless the next horizontal tab position has been set.
 - If the command is received when the printing position is at the right margin, the device executes print buffer full printing and horizontal tab processing from the beginning of the next line.

[Default] Defaul tab positions are set at intervals of 8 characters (9, 17, 25, ...) when the right-side character spacing is 0.

[Reference] [0x1B 0x44](#)

[Example]

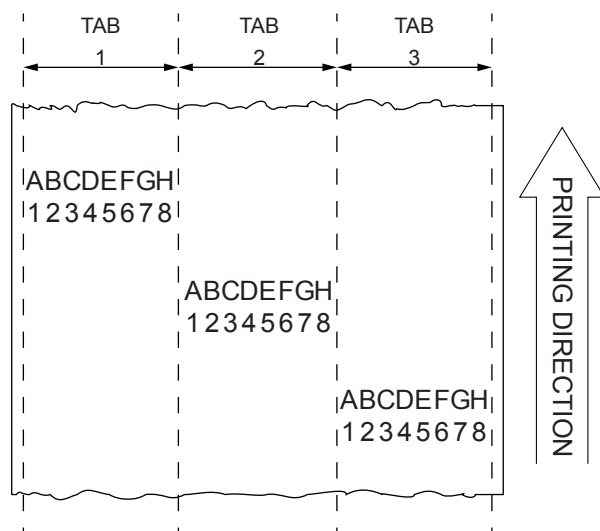



0x1B 0x24

<ESC \$>

Set absolute print position

Valid for	TG1260HIII TG2460HIII, TG2460HIII EJC TG2480HIII TL60III TL80III
-----------	--

[Format]	Hex 1B 24 nL nH ASCII ESC \$ nL nH
----------	---

[Range]	0x00 ≤ nL ≤ 0xFF 0x00 ≤ nH ≤ 0xFF
---------	--------------------------------------

[Description]	Sets the distance from the beginning of the line to the position at which subsequent characters are to be printed. The distance from the beginning of the line to the print position is [(nL + nH × 256) × (vertical or horizontal motion unit)].
---------------	--

[Notes]	<ul style="list-style-type: none"> • Settings outside the specified printable area are ignored. • The horizontal and vertical motion unit are specified by 0x1D 0x50. • 0x1D 0x50 can change the horizontal (and vertical) motion unit. However, the value cannot be less than the minimum horizontal movement amount. • In standard mode, the horizontal motion unit (x) is used. • If the setting is outside the printing area width, it sets the absolute print position, but the left or right margin is set at default value.
---------	---

[Default]

[Reference]	0x1B 0x5C , 0x1D 0x50
-------------	---

[Example]



0x1B 0x28 0x76

<ESC (v>

Set relative vertical print position

Valid for	TG1260HIII TG2460HIII, TG2460HIII EJC TG2480HIII TL60III TL80III					
[Format]	Hex	1B	28	76	nL	nH
	ASCII	ESC	(v	nL	nH
[Range]	0x00 ≤ nL ≤ 0xFF 0x00 ≤ nH ≤ 0xFF					
[Description]	Sets the print vertical position based on the current position by using the horizontal or vertical motion unit. This command sets the distance from the current position to [(nL + nH × 256) × horizontal or vertical motion unit].					
[Notes]	<ul style="list-style-type: none"> • When the starting position is specified by N motion unit to the bottom: nL + nH × 256 = N. • When the starting position is specified by N motion unit to the top (negative direction), use the complement of 65536: nL + nH × 256 = 65536 - N. • The horizontal and vertical motion unit are specified by 0x1D 0x50. • The 0x1D 0x50 command can change the horizontal (and vertical) motion unit. However, the value cannot be less than the minimum horizontal movement amount. • In standard mode, the vertical motion unit is used. 					
[Default]						
[Reference]	0x1D 0x50					
[Example]						



0x1B 0x44

<ESC D>

Set horizontal tab positions

Valid for	TG1260HIII TG2460HIII, TG2460HIII EJC TG2480HIII TL60III TL80III
-----------	--

[Format]	Hex 1B 44 n1...nk 00 ASCII ESC D n1...nk NUL
----------	--

[Range]	0x01 ≤ n ≤ 0xFF 0x00 ≤ k ≤ 0x20
---------	------------------------------------

[Description]	Sets horizontal tab positions <ul style="list-style-type: none"> • n specifies the column number for setting a horizontal tab position calculated from the beginning of the line. • k indicates the total number of horizontal tab positions to be set.
---------------	---

[Notes]	<ul style="list-style-type: none"> • The horizontal tab position is stored as a value of [character width × n] measured from the beginning of the line. The character width includes the right-side character spacing and double-width characters are set with twice the width of normal characters. • This command cancels previous tab settings. • Up to 32 tab positions (k = 0x20) can be set. Data exceeding 32 tab positions is processed as normal data. • Send [n] k in ascending order and place a 0 NUL code at the end. When [n] k is less than or equal to the preceding value [n] k-1, the setting is complete and the data which follows is processed as normal data. • 0x1B 0x44 0x00 cancels all horizontal tab positions. • The previously specified horizontal tab position does not change, even if the character width is modified.
---------	---

[Default]	Default tab positions are set at intervals of 8 characters (columns 9, 17, 25, ...) when the right-side character spacing is 0.
-----------	---

[Reference]	0x09
-------------	------



[Example]

To set a tabulation to column 4 send the command:
0x1B 0x44 0x03 0x00

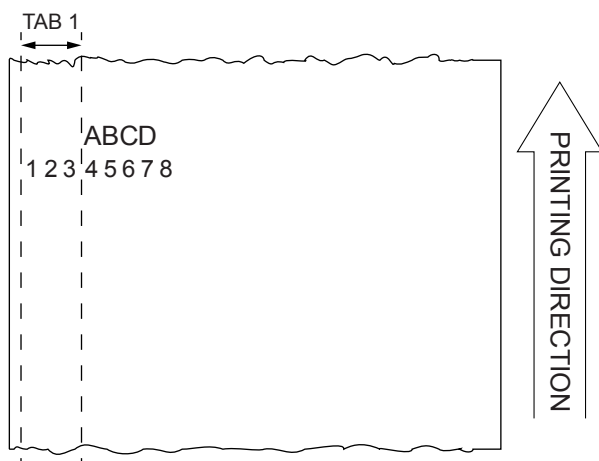

To print the string 'ABCD' to the tabulation previously set, the command sequence is:
0x09 'ABCD'

where:

0x09 move the print position to the set horizontal tab (4th column).
'ABCD' is the string to be printed.



0x1B 0x5C

<ESC \>

Set relative print position

Valid for	TG1260HIII TG2460HIII, TG2460HIII EJC TG2480HIII TL60III TL80III				
[Format]	Hex	1B	5C	nL	nH
	ASCII	ESC	\	nL	nH
[Range]	0x00 ≤ nL ≤ 0xFF 0x00 ≤ nH ≤ 0xFF				
[Description]	Sets the print starting position based on the current position by using the horizontal or vertical motion unit. Sets the distance from the current position to [(nL+ nH × 256) × horizontal or vertical motion unit].				
[Notes]	<ul style="list-style-type: none"> • When the starting position is specified by N motion units to the right: nL + nH × 256 = N. • When the starting position is specified by n motion units to the left (negative direction), use the complement of 65536: nL + nH × 256 = 65536 – N. • If setting exceeds the printing area width, the left or right margin is set to the default value. • The horizontal and vertical motion unit are specified by 0x1D 0x50. • 0x1D 0x50 can change the horizontal (and vertical) motion units. However, the value cannot be less than the minimum horizontal movement amount. • In standard mode, the horizontal motion unit is used. • It's possible to print further on the right margin set for every font. In this case the printing continues up to the maximum border of the device mechanism and then begins a new row. 				
[Default]					
[Reference]	0x1B 0x24 , 0x1D 0x50				
[Example]					



0x1B 0x61

<ESC a>

Select justification

Valid for
 TG1260HIII
 TG2460HIII, TG2460HIII EJC
 TG2480HIII
 TL60III
 TL80III

[Format] Hex 1B 61 n
 ASCII ESC a n

[Range] 0x00 ≤ n ≤ 0x02
 0x30 ≤ n ≤ 0x32

[Description] This command selects the type of justification based on the value of n as follows:

n	JUSTIFICATION
0x00, 0x30	Left justification
0x01, 0x31	Centered
0x02, 0x32	Right justification

[Notes]

- Lines are justified within the specified printing area.
- Spaces set by 0x09, 0x1B 0x24 and 0x1B 0x5C will be justified according to the previously-entered mode.

[Default] n = 0x00

[Reference]

[Example]

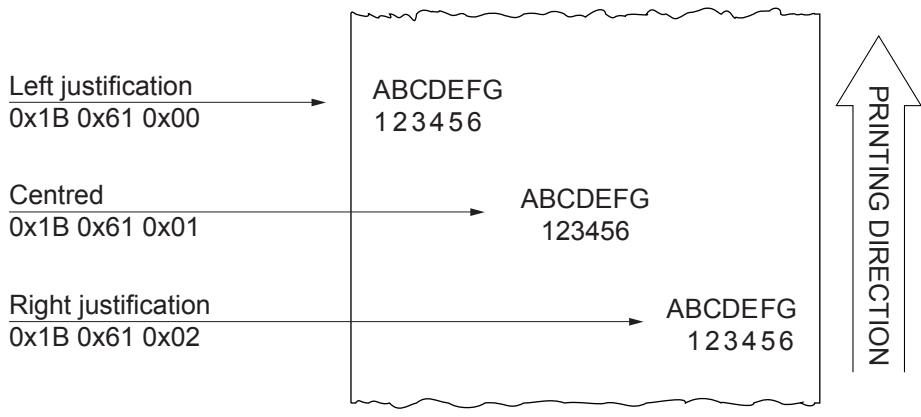

0x1D 0x4C

<GS L>

Set left margin

Valid for	TG1260HIII TG2460HIII, TG2460HIII EJC TG2480HIII TL60III TL80III
-----------	--

[Format]	Hex 1D 4C nL nH ASCII GS L nL nH
----------	--

[Range] 0x00 ≤ nL, nH ≤ 0xFF

[Description] Sets the left margin to [(nL + nH × 256) × horizontal motion unit].

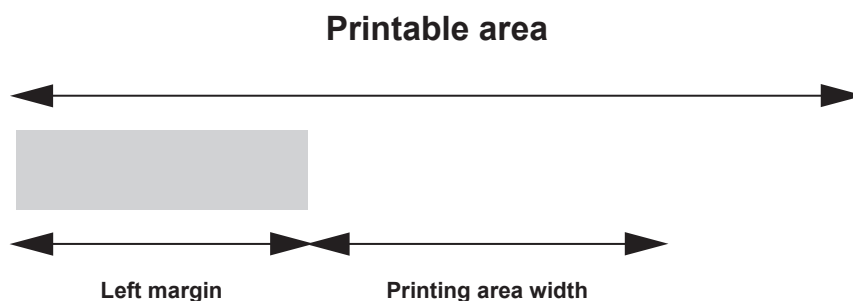

- [Notes]
- If the setting exceeds the printable area, the maximum value of the printable area is used.
 - If the left margin + printing area width is greater than the printable area, the printing area width is set at maximum value.
 - The horizontal and vertical motion unit are specified by [0x1D 0x50](#). Changing the horizontal or vertical motion unit does not affect the current left margin.
 - The [0x1D 0x50](#) command can change the horizontal (and vertical) motion unit.
 - However, the value cannot be less than the minimum horizontal movement amount and it must be in even units of the minimum horizontal movement amount.

[Default]

[Reference] [0x1D 0x50](#), [0x1D 0x57](#)

[Example]

0x1D 0x57

<GS W>

Set printing area width

Valid for	TG1260HIII TG2460HIII, TG2460HIII EJC TG2480HIII TL60III TL80III
-----------	--

[Format]	Hex 1D 57 nL nH ASCII GS W nL nH
----------	--

[Range]	$0x00 \leq nL, nH \leq 0xFF$ $0 \leq (nL + nH \times 256) \leq 640$
---------	--

[Description]	Sets the printing area width to the area specified by nL and nH. The left margin is set to $[(nL + nH \times 256) \times (\text{horizontal motion unit})]$ inches.
---------------	---

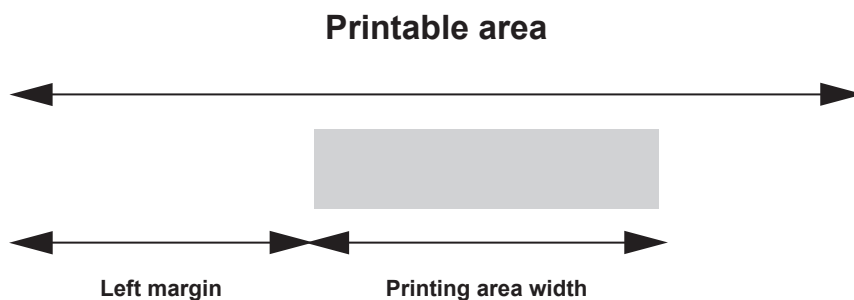

[Notes]	<ul style="list-style-type: none"> • This command is only enabled if set at the beginning of the line. • If the right margin is greater than the printable area, the printing area width is set at maximum value. • If the printing area width = 0, it is set at the maximum value. • The horizontal and vertical motion units are specified by 0x1D 0x50. Changing the horizontal or vertical motion unit does not affect the current left margin. • The 0x1D 0x50 command can change the horizontal (and vertical) motion unit. However, the value cannot be less than the minimum horizontal movement amount and it must be in even units of the minimum horizontal movement amount.
---------	--

[Default]

[Reference] [0x1D 0x4C](#), [0x1D 0x50](#)

[Example]



COMMANDS FOR MECHANISM CONTROL

0x1B 0x69

<ESC i>

Total cut

Valid for	TG1260HIII
	TG2460HIII, TG2460HIII EJC
	TG2480HIII
	TL60III
	TL80III

[Format]	Hex	1B	69
	ASCII	ESC	i

[Range]

[Description] This command enables autocutter operation and executes a total cut.

[Notes] The device waits to complete all paper movement commands before it executes a total cut.

[Default]

[Reference]

[Example]



0x1B 0x6D

<ESC m>

Partial cut

Valid for TL60III

[Format] Hex 1B 6D
 ASCII ESC m

[Range]

[Description] This command enables autocutter operation and executes a partial cut.

[Notes] The device waits to complete all paper movement commands before it executes a partial cut.

[Default]

[Reference]

[Example]



0x1C 0xC0 0x34

Total cut and automatic paper moving back

Valid for	TG1260HIII
	TG2460HIII, TG2460HIII EJC
	TG2480HIII
	TL60III
	TL80III

[Format]	Hex	1C	C0	34
	ASCII	FS	0xC0	4

[Range]

[Description] This command enables autocutter operation and executes a total cut and automatic paper moving back; if there is no autocutter, a disabling flag is set any subsequent cutting commands will be ignored.

[Notes] The device waits until all the paper movement commands have been completed before executing total cut.
After cutting, the ticket is set back to the printing line.

[Default]

[Reference]

[Example]



ALIGNMENT COMMANDS

0x1D 0xE7

Set black mark distance

Valid for	TG1260HIII TG2460HIII, TG2460HIII EJC TG2480HIII TL60III TL80III
[Format]	Hex 1D E7 nL nH ASCII GS 0xE7 nL nH
[Range]	0x00 ≤ nH ≤ 0xFF 0x00 ≤ nL ≤ 0xFF
[Description]	Sets black mark distance in tenth of millimeter of the alignment point from the edge of the black mark. This value is expressed as [(nH × 256) + nL] where: - if nH ≤ 0x7F, the value will be positive. - if nH > 0x7F, the value will be negative.
[Notes]	<ul style="list-style-type: none">• The maximum value is 99.9 mm.• The minimum value is -19.9 mm.• The distance is saved in nonvolatile memory: it is therefore recommended not to send this command for each printed ticket, because the number of rewrites is limited. In many devices, however, is checked the diversity of the data before performing the rescue to avoid reaching the limit of rewrites.• The distance defined by this command is the same that can be set with the value of the “Black Mark Distance” during the setup of the device (see user manual for further explanation).
[Default]	nH = 0x00 nL = 0x00
[Reference]	



[Example]

To set a distance of the alignment point from the black mark equal to 8 mm = 80 tenths of a millimeter, send the command:

```
0x1D 0xE7 0x00 0x50
```

where:

0x00 the most significant bit (MSB = 0) defines the sign +

0x00 0x50 the absolute value defines the distance = 80 tenths of a millimeter

To set a distance of the alignment point from the black mark equal to - 8 mm, send the command:

```
0x1D 0xE7 0x80 0x50
```

where:

0x80 the most significant bit (MSB = 1) defines the sign -

0x80 0x50 the absolute value defines the distance = 80 tenths of a millimeter

The following images show tickets with alignment point positioned at 8 mm and -8 mm from the black mark.

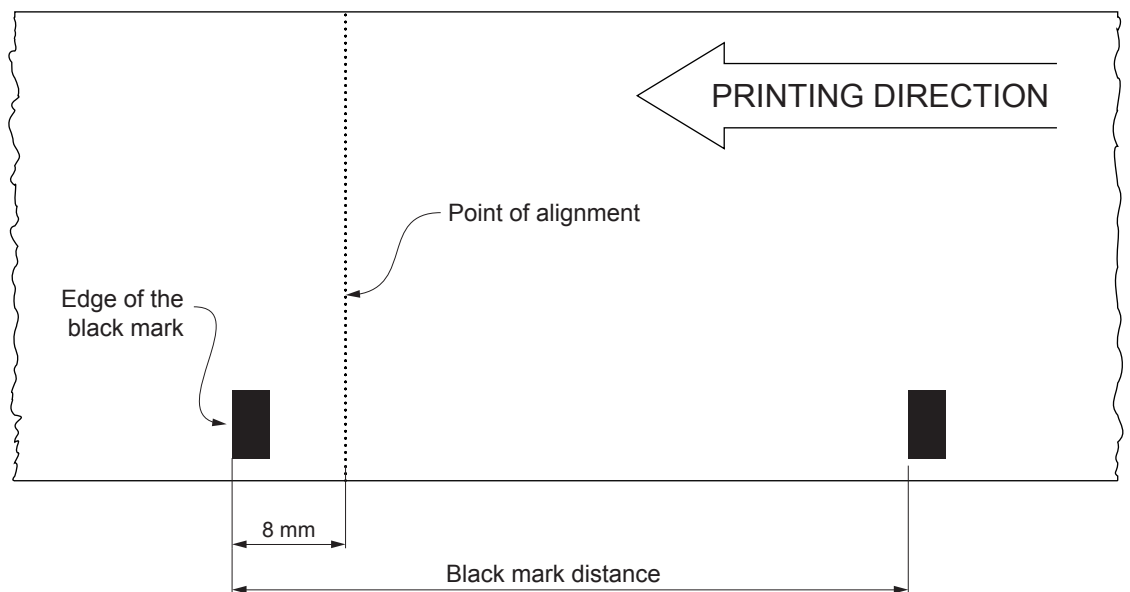
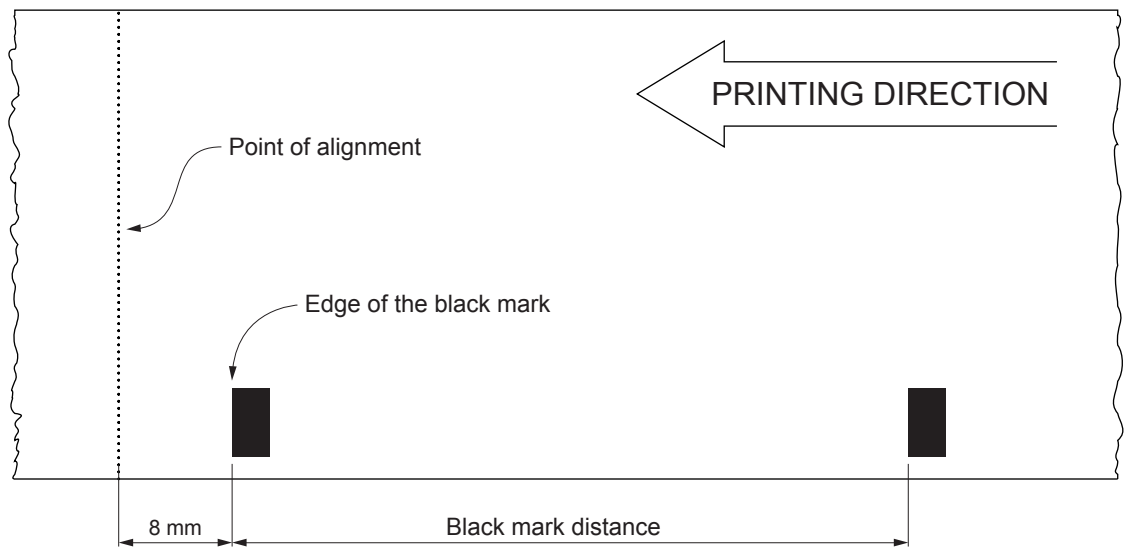



0x1D 0xF6

Align the ticket with the printhead

Valid for	TG1260HIII TG2460HIII, TG2460HIII EJC TG2480HIII TL60III TL80III
-----------	--

[Format]	Hex	1D	F6
	ASCII	GS	0xF6

[Range]

[Description] This command align the edge of black mark to the alignment point (see [ALIGNMENT](#) section for further explanation).

- [Notes]
- Use [0x1D 0xE7](#) command to set the distance between the edge of black mark and the alignment point.
 - To work properly, the “Black Mark Position” parameter must be enabled during the setup procedure (refer to the user manual of each device).
 - Use this alignment command even to print more tickets without cutting.

[Default]

[Reference] [0x1D 0xE7](#), [0x1D 0xF8](#)

[Example]



0x1D 0xF8

Align the ticket with the autocutter

Valid for	TG1260HIII TG2460HIII, TG2460HIII EJC TG2480HIII TL60III TL80III
-----------	--

[Format]	Hex	1D	F8
	ASCII	GS	0xF8

[Range]

[Description] This command align the edge of the black mark to the alignment point (see [ALIGNMENT](#) section for further explanation).

[Notes]

- Use [0x1D 0xE7](#) command to set distance between the edge of the ticket and the alignment point.
- To work properly, the “Black Mark Position” parameter must be enabled during the setup procedure (refer to the user manual of each device).
- Use this alignment command even to print more tickets without cutting.

[Default]

[Reference] [0x1D 0xE7](#), [0x1D 0xF6](#)

[Example]



EJECTOR COMMANDS

0x1C 0x50

<FS P>

Ejector management

Valid for TG2460HIII EJC

[Format] Hex 1C 50 a b
 ASCII FS P a b

[Range] a = 0x00, 0x01
 0x00 ≤ b ≤ 0xFF

[Description] This command cuts the paper and present/retract the ticket according to a value as described in the following table:

a	FUNCTION
0x00	Eject printed ticket
0x01	Present printed ticket

If a = 0x01, b indicates the timeout (in seconds) for the ticket ejection (0x01 = 1 second).

[Notes]

[Default] a = 0x00

[Reference]

[Example]

a = 0x00

The device starts the ticket printing.

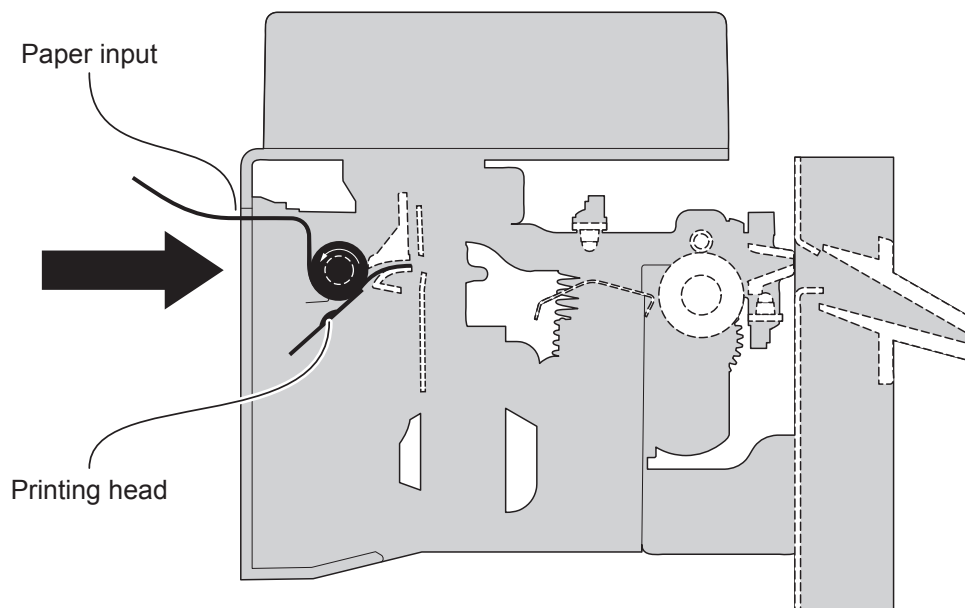

The ticket advances ahead to engage the ejector sensor and is caught between the ejector rollers. The printed portion of ticket is collected in the space between autocutter and ejector while the device continues printing.

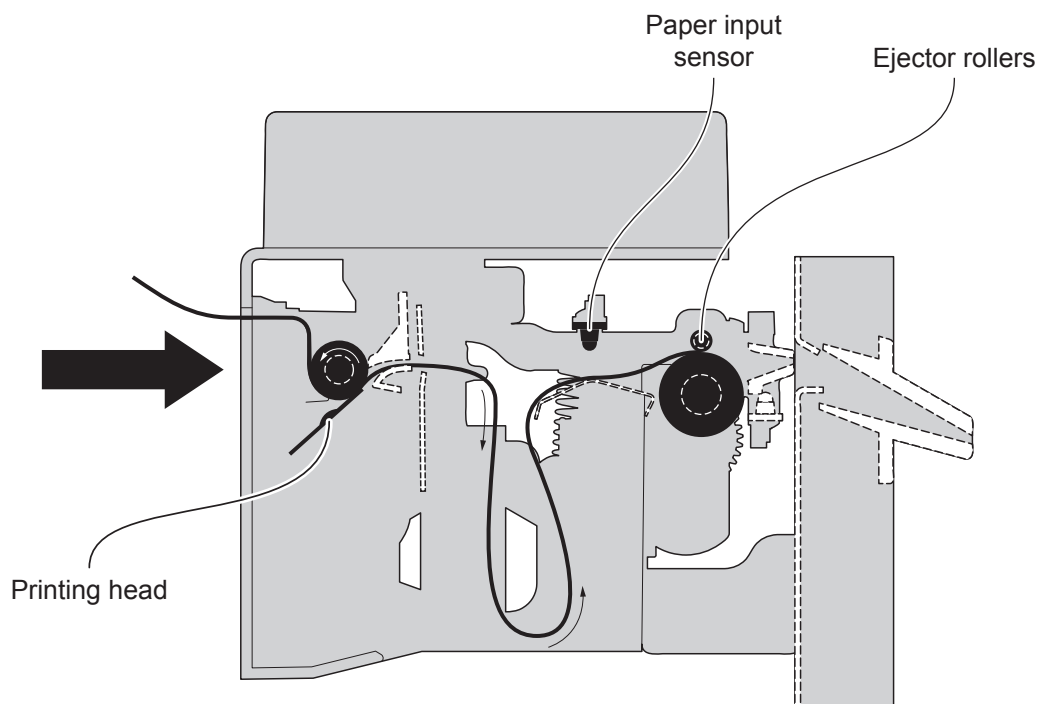

When printing ends, the device cuts the ticket printed.

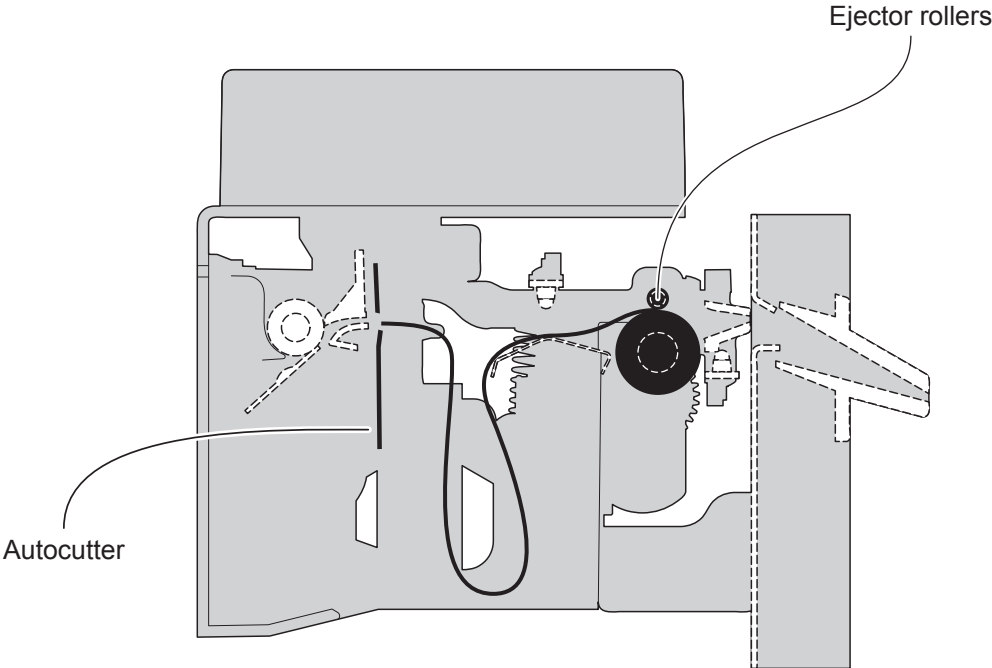

The device directly ejects the ticket.

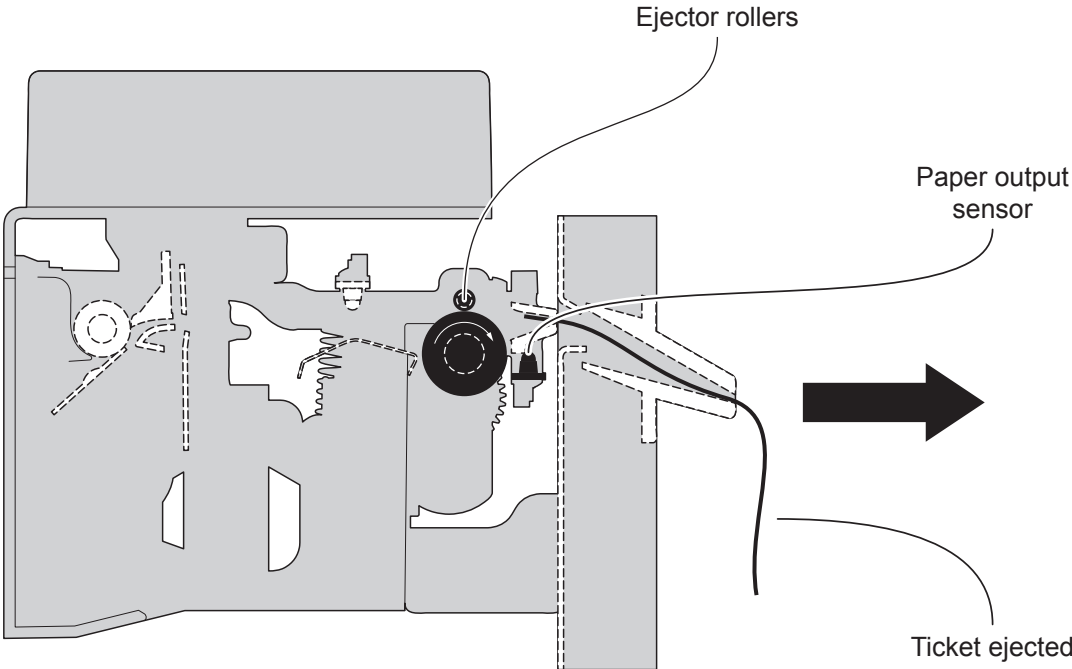

a = 0x01

The device starts the ticket printing.

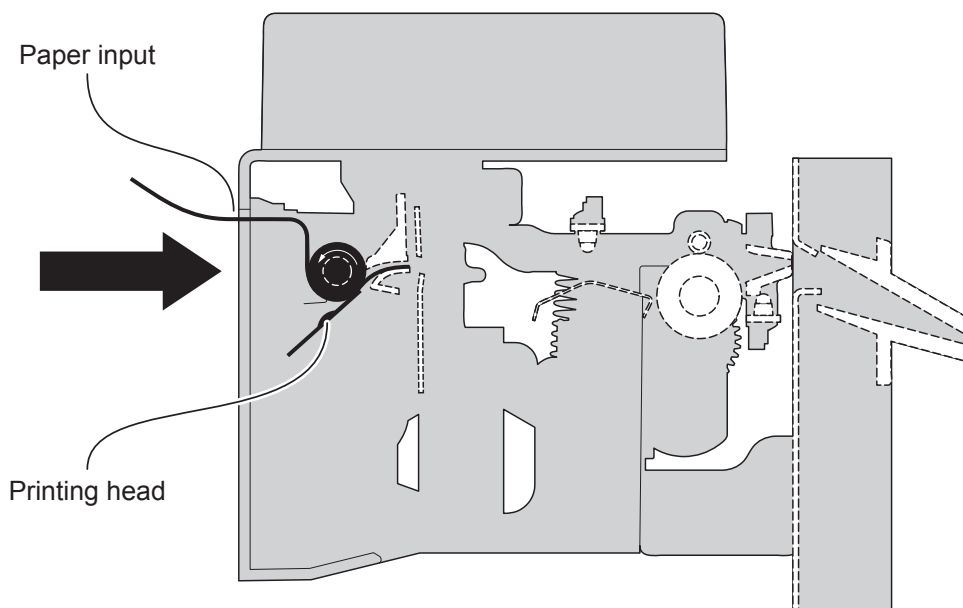

The ticket advances ahead to engage the ejector sensor and is caught between the ejector rollers. The printed portion of ticket is collected in the space between autocutter and ejector while the device continues printing.

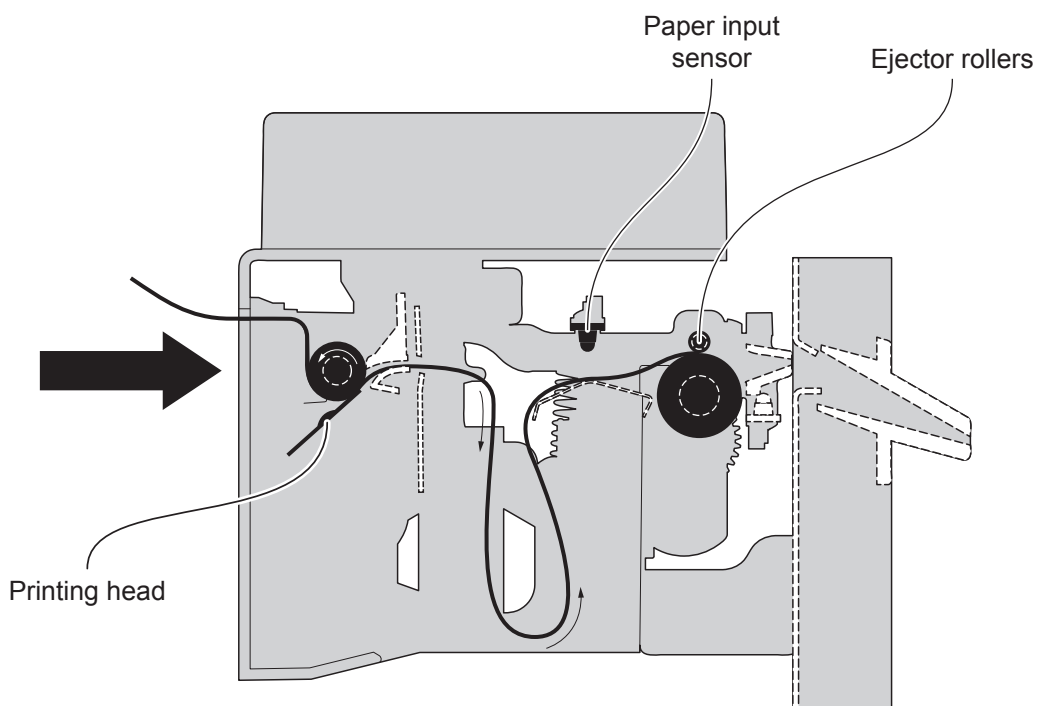



When printing ends, the device cuts the ticket printed.

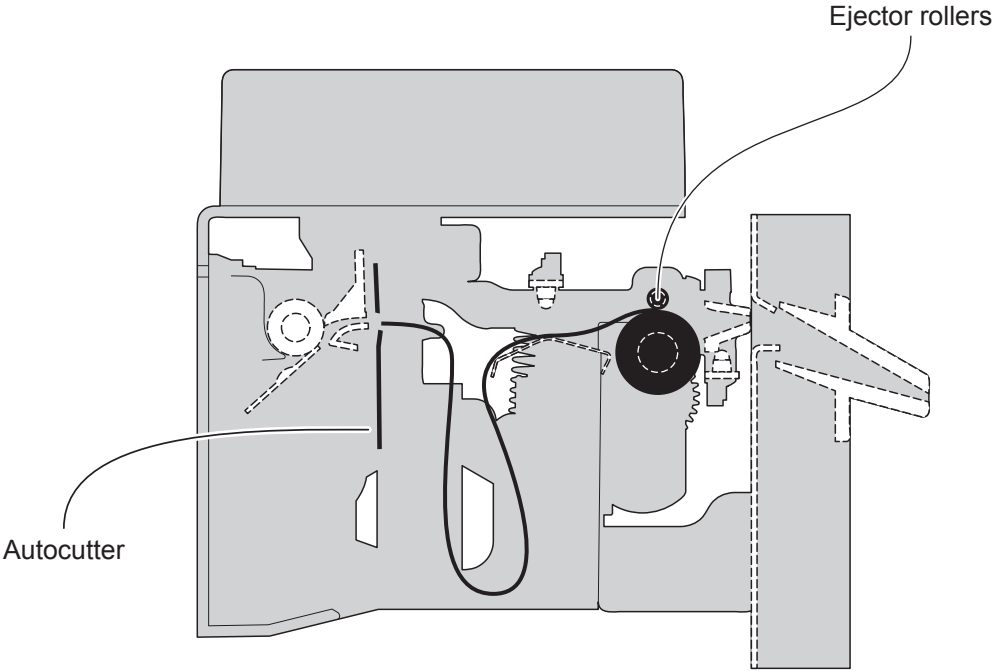

The device presents a portion of the ticket printed on the paper mouth.

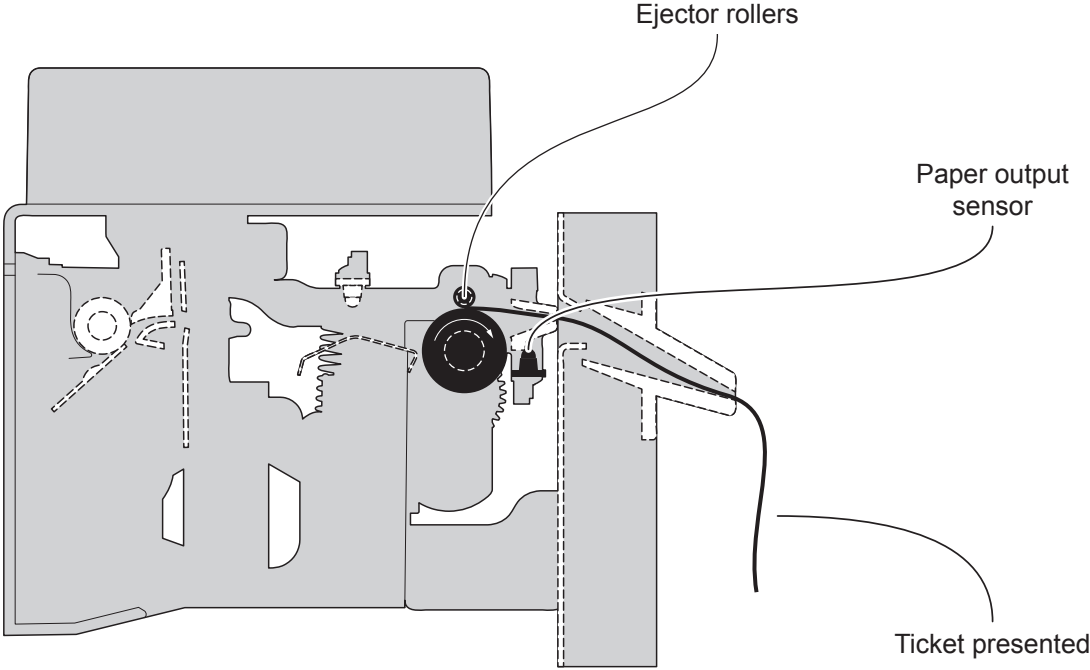



The ticket is waiting on the paper mouth for a preset period of time.

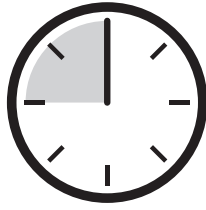

The device directly ejects the ticket.

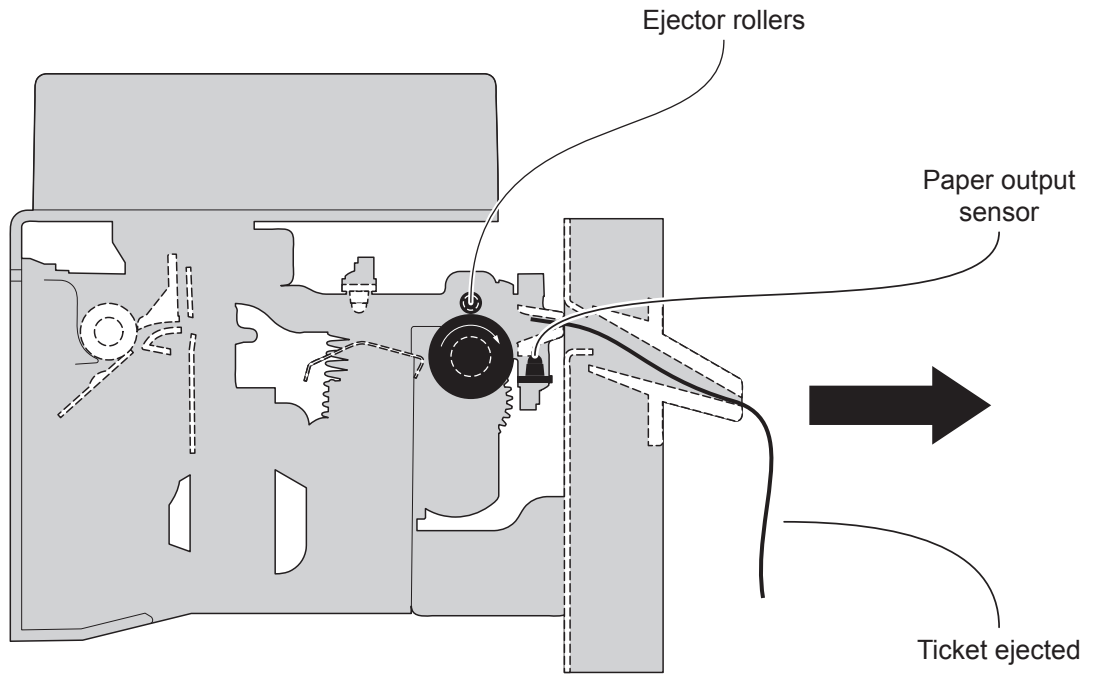



ANTI-JAMMING COMMANDS

0x1C 0xC1

Enable or disable automatic anti-jamming movement

Valid for	TG1260HIII
	TG2460HIII
	TG2480HIII

[Format]	Hex	1C	C1	n
	ASCII	FS	0xC1	n

[Range]	n = 0x00, 0x01
	n = 0x30, 0x31

[Description] The ticket withdrawal before the end of printing, may damage the printing mechanism or the paper ripping resulting in probably jam.

The anti-jamming system is composed of an oscillating plane placed under the inspection door and of a fork sensor that detects the oscillating plane movement.

This command enables or disables the automatic anti-jamming movement that must be performed when the inspection door is lifted.

The command works as described in the following table according to the n value:

n	FUNCTION
0x00, 0x30	Disable the anti-jamming movement at the lift of the inspection door
0x01, 0x31	Enable the anti-jamming movement at the lift of the inspection door

[Notes]

[Default]	n = 0x00
-----------	----------

[Reference]

[Example]



0x1D 0xDC

Perform the anti-jamming movement

Valid for	TG1260HIII
	TG2460HIII
	TG2480HIII

[Format]	Hex	1D	DC
	ASCII	GS	0xDC

[Range]

[Description] This command performs the anti-jamming movement regardless of the settings of the command [0x1C 0xC1](#) and the position of the inspection door.

[Notes]

[Default]

[Reference] [0x1C 0xC1](#)

[Example]



MISCELLANEOUS COMMANDS

0x1B 0x3D

<ESC =>

Select peripheral device

Valid for

- TG1260HIII
- TG2460HIII, TG2460HIII EJC
- TG2480HIII
- TL60III
- TL80III

[Format]

Hex	1B	3D	n
ASCII	ESC	=	n

[Range] 0x01 ≤ n ≤ 0x03

[Description] Select the device to which the host computer sends data, using n as follows:

n	FUNCTION
0x01, 0x03	Device enabled
0x02	Device disabled

[Notes] When the device is disabled, it ignores all transmitted data until the device is enabled through this command.

[Default] n = 0x01

[Reference]

[Example]



0x1B 0x40

<ESC @>

Initialize device

Valid for	TG1260HIII
	TG2460HIII, TG2460HIII EJC
	TG2480HIII
	TL60III
	TL80III

[Format]	Hex	1B	40
	ASCII	ESC	@

[Range]

[Description] Clears the data in the print buffer and resets the device mode to that in effect when power was turned on.

[Notes]

- The data in the receiver buffer is not cleared.
- The macro definitions are not cleared.

[Default]

[Reference]

[Example]



0x1B 0x4B

<ESC K>

Power on or off LED bar

Valid for TG1260HIII
TG2460HIII, TG2460HIII EJC
TG2480HIII

[Format] Hex 1B 4B n
ASCII ESC K n

[Range] $0x00 \leq n \leq 0x02$

[Description] Power on or off the LED bar based on the value of n as follows:

n	FUNCTION
0x00	Power off LED bar
0x01	Power on LED bar
0x02	Returns to automatic mode

[Notes]

[Default]

[Reference]

[Example]



0x1B 0x63 0x35

<ESC c 5>

Enable or disable keys panel

Valid for	TG1260HIII TG2460HIII, TG2460HIII EJC TG2480HIII TL60III TL80III
-----------	--

[Format]	Hex	1B	63	35	n
	ASCII	ESC	c	5	n

[Range] $0x00 \leq n \leq 0xFF$

[Description] Enables or disables the keys panel, based on the value of n
- when the Least Significant Bit (LSB) of n is 0, the keys panel is enabled.
- when the Least Significant Bit (LSB) of n is 1, the keys panel is disabled.

[Notes]

- Only the Least Significant Bit (LSB) of n is effective.
- When the keys panel is disabled, the keys may only be used after the device has been reset.

[Default] n = 0x00

[Reference]

[Example]



0x1B 0x78

<ESC x>

Select print mode

Valid for TG1260HIII
 TG2460HIII, TG2460HIII EJC
 TG2480HIII
 TL60III
 TL80III

[Format] Hex 1B 78 n
 ASCII ESC x n

[Range] n = 0x00, 0x01

[Description] This command selects a print mode based on the quality/speed ratio specified by n as follows:

n	FUNCTION
0x00	Normal mode
0x01	High quality / low speed

[Notes]

[Default] n = 0x00

[Reference]

[Example]



0x1C 0x3C

<FS >

Change emulation

Valid for TG1260HIII
TG2460HIII, TG2460HIII EJC
TG2480HIII
TL60III
TL80III

[Format] Hex 1C 3C
ASCII FS <

[Range]

[Description] Change device emulation.

[Notes]

[Default]

[Reference]

[Example]



0x1C 0x80

Read date/time of the real time clock

Valid for TG1260HIII
TG2460HIII, TG2460HIII EJC
TG2480HIII
TL60III
TL80III

[Format] Hex 1C 80 m
ASCII FS 0x80 m

[Range] $0x00 \leq m \leq 0x03$

[Description] Read date/time of the real time clock in the format specified by m values as follows:

m	FORMAT
0x00	DD/MM/YY hh:mm:ss
0x01	DDMMYYhhmmss
0x02	YYMMDDhhmmss
0x03	YYMMDDkkmmssd

where:

DD represents the day of the date
MM represents the month of the date
YY represents the year of the date
hh represents the hour of the time
mm represents the minutes of the time
ss represents the seconds of the time
d represents the day of the week

[Notes] Before send the date/time, if the m parameter is valid the device transmits the ACK (0x06) followed by the number of bytes to sent, otherwise return NACK (0x15).

[Default]

[Reference]

[Example] To read date/time in the “DDYYMMhhmmss” format, send the command sequence:
0x1C 0x80 0x01

If the current date/time are “15 September 2006 at 10:56:20 (AM)”, the device answers as follows:

in Hex: 0x06 0x0C 0x31 0x35 0x30 0x39 0x30 0x36 0x31 0x30 0x35 0x36 0x32 0x30

in ASCII: ACKFF150906105620



0x1C 0x81

Set date/time of the real time clock

Valid for	TG1260HIII TG2460HIII, TG2460HIII EJC TG2480HIII TL60III TL80III
-----------	--

[Format]	Hex	1C	81	m	n	d0...dn
	ASCII	FS	0x81	m	n	d0...dn

[Range]	0x00 ≤ m ≤ 0x03 0x00 ≤ d0, dn ≤ 0xFF
---------	---

[Description] Set date/time of the real time clock in the format specified by m values as follows:

m	FORMAT
0x00	DD/MM/YY hh:mm:ss
0x01	DDMMYYhhmmss
0x02	YYMMDDhhmmss
0x03	YYMMDDkkmmssd

where:

DD	represents the day of the date
MM	represents the month of the date
YY	represents the year of the date
hh	represents the hour of the time
mm	represents the minutes of the time
ss	represents the seconds of the time
d	represents the day of the week

- n specifies the number of characters to send.
- d0...dn are the ASCII characters relative to the date and time to set.

[Notes]

- If the transmission has been received correctly and the command is valid, the device returns the ACK (0x06), otherwise returns NACK (0x15).
- The day of the week is calculated automatically from the device and then it's possible that the returned value is different from the one transmitted.

[Default]

[Reference]

[Example] To set the date and time to "29 September 2006 at 13:51:00 (PM)" in the "YYMMDDhhmmss" format, send the command sequence:
0x1C 0x81 0x02 0x0C 0x30 0x36 0x30 0x39 0x32 0x39 0x31 0x33 0x35 0x31 0x30 0x30

0x1C 0x84

Set user-defined date/time formats

Valid for	TG1260HIII TG2460HIII, TG2460HIII EJC TG2480HIII TL60III TL80III
-----------	--

[Format]	Hex 1C 84 n d1...dk 0x00 ASCII FS 0x84 n d1...dk NUL
----------	---

[Range]	n = 0x44, 0x54 0x00 ≤ d0, dK ≤ 0xFF
---------	--

[Description]	<p>Sets the format string for date and time used to printing.</p> <ul style="list-style-type: none"> • n specifies which user-defined string format is set: <ul style="list-style-type: none"> - 0x44 for date - 0x54 for time • d0..dk are the ASCII characters relative to user-defined date/time formats. • The maximum length of the user-defined date/time format string is 64 chars. • The following table shows characters used to create user-defined date/time formats:
---------------	---

CHARACTER	DESCRIPTION
I	Select Italian language
E	Select English language (default language)
c	Select default data/time
d	Displays the day as a number without a leading zero (1-31)
dd	Displays the day as a number with a leading zero (01-31)
ddd	Displays the day as an abbreviation (for example, Sun)
dddd	Displays the day as a full name (for example, Sunday)
dddddd	Displays the date as a complete date in the short format where date values are formatted with day, month and year (the short date format is dd/mm/yy)
dddddd	Displays the date as a complete date in the extended format where date values are formatted with day, month and year (the extended date format is dd mmmm, yyyy)
m	Displays the month as a number without a leading zero (1-12). If the character m is immediately after the character h or hh ,displays the minutes instead of month (see also the n character formatting)
mm	Displays the month as a number with leading zeros (01-12). If the character m is immediately after the character h or hh , displays the minutes instead of month (see also the nn character formatting)
mmm	Displays the month as an abbreviation (for example, Jan)
mmmm	Displays the month as a full month name (for example, January)



yy	Displays the year in two-digit numeric format with a leading zero
yyyy	Displays the year in four digit numeric format
CHARACTER	DESCRIPTION
h	Displays the hour as a number without leading zeros (0-23)
hh	Displays the hour as a number with leading zeros (00-23)
n	Displays the minutes as a number without leading zeros (0-59)
nn	Displays the minutes as a number with leading zeros (00-59)
s	Displays the seconds as a number without leading zeros (0-59)
ss	Displays the seconds as a number with leading zeros (00-59)
tttt	Displays the time in the extended format where time values are formatted with hour, minutes and seconds (the extended time format is h:mm:ss).
AM/PM	Using the 12-hour clock and displays the AM prefix in uppercase next to the hours that preceding midday and the PM prefix in uppercase next to the hours between midday and midnight.
am/pm	Using the 12-hour clock and displays the am prefix in lowercase next to the hours that preceding midday and the pm prefix in lowercase next to the hours between midday and midnight.
A/P	Using the 12-hour clock and displays the A prefix in uppercase next to the hours that preceding midday and the a prefix in uppercase next to the hours between midday and midnight.
a/p	Using the 12-hour clock and displays the a prefix in lowercase next to the hours that preceding midday and the a prefix in lowercase next to the hours between midday and midnight.

[Notes] The device returns ACK (0x06) if the transmission is OK otherwise NACK (0x15).

[Default]

[Reference]

[Example] To print the current time with the string format 'yy/mm/dd hh:mm:ss' follow these steps:

1. Send the following command to define the user-defined time string format:
0x1C 0x84 0x54 0x79 0x79 0x2F 0x6D 0x6D 0x2F 0x64 0x64 0x20 0x68 0x68 0x3A 0x6E 0x6E 0x3A
0x73 0x73 0x00

2. Send the following command to print the time:
0x1C 0x83 0x0A

The character 0x0A feeds one line based on the current line spacing.
If the date and time is 22 October 2006 at 17:35:27 (PM) the output string printed will be:
06/10/22 17:35:27



0x1C 0xB0

Minimum ticket length reading

Valid for

- TG1260HIII
- TG2460HIII, TG2460HIII EJC
- TG2480HIII
- TL60III
- TL80III

[Format]

Hex	1C	B0
ASCII	FS	0xB0

[Range]

[Description]

Send this command to read the minimum ticket length in millimeters.
The device replies with 2 byte that identify the length as follows:
nH = tens
nL = units

[Note]

[Default]

[Reference] [0x1D 0xE8](#)

[Example]

If the two bytes of reply are:
nH = 03
nL = 08
The ticket length is 56 mm.



0x1C 0xEF

Set device in low power mode

Valid for

- TG1260HIII
- TG2460HIII, TG2460HIII EJC
- TG2480HIII
- TL60III
- TL80III

[Format]

Hex	1C	EF	0xAE	0x01
ASCII	FS	0xEF	0XAE	SOH

[Range]

[Description] This command sets the device in low power mode.

[Note]

[Default]

[Reference]

[Example]



0x1D 0x49

<GS />

Transmit device ID

Valid for

TG1260HIII
 TG2460HIII, TG2460HIII EJC
 TG2480HIII
 TL60III
 TL80III

[Format]

Hex	1D	49	n
ASCII	GS	I	n

[Range]

0x01 ≤ n ≤ 0x03
 0x31 ≤ n ≤ 0x33
 n = 0xFF

[Description] Transmits the device ID specified by n follows:

n	DEVICE ID	SPECIFICATION
0x01, 0x31	Device model ID (1 byte)	0x30 (TG1260HIII) 0xA7 (TG2460HIII, TG2460HIII EJC) 0xA8 (TG2480HIII) 0xAD (TL60III) 0xAC (TL80III)
0x02, 0x32	Type ID	See table below
0x03, 0x33	ROM version ID (4 bytes)	Depends on ROM version (4 character)
0xFF	Device model ID (2 bytes)	(see value for n = 0x01)

n = 0x02, 0x32 Type ID

BIT	OFF/ON	HEX	FUNCTION
0	Off	00	2 bytes characters codes not supported
1	Off	00	Autocutter not supplied
	On	02	Autocutter supplied
2	Off	00	Thermal paper w/o label
	On	04	Thermal paper label
3	-	-	Undefined
4	Off	00	Not used. Fixed to off
5	-	-	Undefined
6	-	-	Undefined
7	Off	00	Not used. Fixed to off



[Notes] This command is executed when the data is processed in the data buffer. Therefore, there could be a time lag between command reception and data transmission, depending on data buffer status.

[Default]

[Reference]

[Example]



0x1D 0x50

<GS P>

Set horizontal and vertical motion units

Valid for	TG1260HIII TG2460HIII, TG2460HIII EJC TG2480HIII TL60III TL80III
-----------	--

[Format]	Hex 1D 50 x y ASCII GS P x y
----------	--

[Range] 0x00 ≤ x, y ≤ 0xFF

[Description] Sets the horizontal and vertical motion units to 1/x inch and 1/y inch respectively.
When x is set to 0, the default setting value is used.
When y is set to 0, the default setting value is used.

[Notes]

- The horizontal direction is perpendicular to the paper feed direction.
- In standard mode, the following commands use x or y, regardless of character rotation (upside-down or 90° clockwise rotation):

Commands using x: [0x1B 0x20](#), [0x1B 0x24](#), [0x1B 0x5C](#), [0x1D 0x4C](#), [0x1D 0x57](#).
Commands using y: [0x1B 0x33](#), [0x1B 0x4A](#).

- This command does not affect the previously specified values.
- The calculated result from combining this command with others is truncated to the minimum value of the mechanical pitch or an exact multiple of that value.

[Default] x = 0xCC, y = 0xCC

[Reference] [0x1B 0x20](#), [0x1B 0x24](#), [0x1B 0x5C](#), [0x1B 0x33](#), [0x1B 0x4A](#), [0x1D 0x4C](#), [0x1D 0x57](#)

[Example]



0x1D 0xE8

Set minimum ticket length

Valid for	TG1260HIII TG2460HIII, TG2460HIII EJC TG2480HIII TL60III TL80III
-----------	--

[Format]	Hex 1D E8 n ASCII GS 0xE8 n
[Range]	$0x00 \leq n \leq 0xFF$
[Description]	This command sets the minimum ticket length to the n value.
[Notes]	
[Default]	TG1260HIII, TG2460HIII 45 mm TG2460HIII EJC 94 mm TG2480HIII 87 mm TL60III, TL80III 40 mm
[Reference]	
[Example]	To set the minimum ticket length at 56 mm, the command sequence is: 0x1D 0xE8 0x00 0x38



0x1D 0xF0

Set print mode

Valid for

TG1260HIII
TG2460HIII, TG2460HIII EJC
TG2480HIII
TL60III
TL80III

[Format]

Hex	1D	F0	n
ASCII	GS	0xF0	n

[Range]

$0x00 \leq n \leq 0x02$

[Description]

Sets print mode based on the value of n as follows:

n	PRINT MODE
0x00	High quality
0x01	Normal
0x02	High speed

[Notes]

Print mode reverts to the default value when the device is reset or turned off.

[Default]

n = 0x02

[Reference]

[Example]



CUSTOM/POS EMULATION

1	COMMANDS LISTED IN ALPHANUMERIC ORDER.....	144
2	COMMANDS LISTED BY FUNCTION	148



1 COMMANDS LISTED IN ALPHANUMERIC ORDER

0x08	<BS>	236
0x09	<HT>	237
0x0A	<LF>	206
0x0D	<CR>	207
0x10 0x04	<DLE EOT>	213
0x18	<CAN>	182
0x1B 0x20	<ESC SP>	183
0x1B 0x21	<ESC !>	184
0x1B 0x24	<ESC \$>	238
0x1B 0x25	<ESC %>	186
0x1B 0x26	<ESC &>	187
0x1B 0x28 0x76	<ESC (v>	239
0x1B 0x2A	<ESC *>	225
0x1B 0x2D	<ESC ->	188
0x1B 0x30	<ESC 0>	203
0x1B 0x32	<ESC 2>	204
0x1B 0x33	<ESC 3>	205
0x1B 0x34	<ESC 4>	189
0x1B 0x3D	<ESC =>	262
0x1B 0x3F	<ESC ?>	190
0x1B 0x40	<ESC @>	263
0x1B 0x44	<ESC D>	240
0x1B 0x45	<ESC E>	191
0x1B 0x47	<ESC G>	192
0x1B 0x4A	<ESC J>	208
0x1B 0x4D	<ESC M>	193



0x1B 0x52	<ESC R>	194
0x1B 0x56	<ESC V>	195
0x1B 0x5C	<ESC \>	242
0x1B 0x61	<ESC a>	243
0x1B 0x63 0x35	<ESC c 5>	264
0x1B 0x64	<ESC d>	209
0x1B 0x69	<ESC i>	248
0x1B 0x6D	<ESC m>	249
0x1B 0x74	<ESC t>	196
0x1B 0x7B	<ESC {>	198
0x1B 0xC1		199
0x1C 0x25	<FS %>	200
0x1C 0x3C	<FS <>	265
0x1C 0x50	<FS P>	256
0x1C 0x70	<FS p>	227
0x1C 0x71	<FS q>	229
0x1C 0x80		266
0x1C 0x81		267
0x1C 0x82		210
0x1C 0x83		211
0x1C 0x84		268
0x1C 0xC0 0x34		250
0x1C 0xEA		219
0x1C 0xEF		270
0x1D 0x21	<GS !>	201
0x1D 0x28 0x6B	<GS (k>	154
0x1D 0x28 0x6B [Fn 165]	<GS (k>	156
0x1D 0x28 0x6B [Fn 166]	<GS (k>	157



0x1D 0x28 0x6B [Fn 167]	<GS (k>	161
0x1D 0x28 0x6B [Fn 169]	<GS (k>	162
0x1D 0x28 0x6B [Fn 180]	<GS (k>	163
0x1D 0x28 0x6B [Fn 181]	<GS (k>	164
0x1D 0x28 0x6B [Fn 182]	<GS (k>	165
0x1D 0x28 0x6B [Fn Q65]	<GS (k>	167
0x1D 0x28 0x6B [Fn Q66]	<GS (k>	168
0x1D 0x28 0x6B [Fn Q67]	<GS (k>	169
0x1D 0x28 0x6B [Fn Q68]	<GS (k>	170
0x1D 0x28 0x6B [Fn Q80]	<GS (k>	171
0x1D 0x28 0x6B [Fn Q81]	<GS (k>	172
0x1D 0x2A	<GS *>	231
0x1D 0x2F	<GS />	233
0x1D 0x3A	<GS :>	246
0x1D 0x42	<GS B>	202
0x1D 0x48	<GS H>	173
0x1D 0x49	<GS I>	271
0x1D 0x4C	<GS L>	244
0x1D 0x50	<GS P>	273
0x1D 0x56	<GS V>	251
0x1D 0x57	<GS W>	245
0x1D 0x5E	<GS ^>	247
0x1D 0x66	<GS f>	175
0x1D 0x68	<GS h>	176
0x1D 0x6B	<GS k>	177
0x1D 0x76 0x30	<GS v 0>	234
0x1D 0x77	<GS w>	180
0x1D 0x7C	<GS >	212



0x1D 0xE0	220
0x1D 0xE1	221
0x1D 0xE2	222
0x1D 0xE3	223
0x1D 0xE5	224
0x1D 0xE6	274
0x1D 0xE7	252
0x1D 0xE9	275
0x1D 0xF0	276
0x1D 0xF6	254
0x1D 0xF8	255



2 COMMANDS LISTED BY FUNCTION

COMMANDS FOR BARCODE PRINTING

0x1D 0x28 0x6B <GS (k>	154
Print two-dimensional barcode	
0x1D 0x28 0x6B [Fn 165] <GS (k>	156
Specify encoding scheme of QRcode barcode	
0x1D 0x28 0x6B [Fn 166] <GS (k>	157
Specify QRcode barcode version	
0x1D 0x28 0x6B [Fn 167] <GS (k>	161
Specify dot size of the module of the QRcode barcode	
0x1D 0x28 0x6B [Fn 169] <GS (k>	162
Specify the error correction level of the QRcode barcode	
0x1D 0x28 0x6B [Fn 180] <GS (k>	163
Store the data in the barcode save area for printing in QRcode format	
0x1D 0x28 0x6B [Fn 181] <GS (k>	164
Prints the data stored in the barcode save area in QRcode format	
0x1D 0x28 0x6B [Fn 182] <GS (k>	165
Transmit the QRcode barcode size in the barcode save area	
0x1D 0x28 0x6B [Fn Q65] <GS (k>	167
Specify the encoding scheme of DATAMATRIX barcode	
0x1D 0x28 0x6B [Fn Q66] <GS (k>	168
Set rotation of DATAMATRIX barcode	
0x1D 0x28 0x6B [Fn Q67] <GS (k>	169
Set dot size of the module of DATAMATRIX barcode	
0x1D 0x28 0x6B [Fn Q68] <GS (k>	170
Set size of DATAMATRIX barcode	
0x1D 0x28 0x6B [Fn Q80] <GS (k>	171
Store the DATAMATRIX barcode data in the barcode save area	
0x1D 0x28 0x6B [Fn Q81] <GS (k>	172
Encodes and prints the data stored in the barcode save area in DATAMATRIX format	
0x1D 0x48 <GS H>	173
Select printing position of HRI characters in 1D barcodes	
0x1D 0x66 <GS f>	175
Select font for HRI characters	
0x1D 0x68 <GS h>	176
Set 1D barcode height	



0x1D 0x6B	<GS k>	177
Print 1D barcode		
0x1D 0x77	<GS w>	180
Set 1D barcode width		

CHARACTER COMMANDS

0x18	<CAN>	182
Cancel current line transmitted		
0x1B 0x20	<ESC SP>	183
Set right-side character spacing		
0x1B 0x21	<ESC !>	184
Select print modes		
0x1B 0x25	<ESC %>	186
Enable or disable user-defined characters		
0x1B 0x26	<ESC &>	187
Defines user-defined characters		
0x1B 0x2D	<ESC ->	188
Turn underline mode on or off		
0x1B 0x34	<ESC 4>	189
Turn italic mode on or off		
0x1B 0x3F	<ESC ?>	190
Cancel user-defined characters		
0x1B 0x45	<ESC E>	191
Turn bold mode on or off		
0x1B 0x47	<ESC G>	192
Turn double-strike mode on or off		
0x1B 0x4D	<ESC M>	193
Select character font		
0x1B 0x52	<ESC R>	194
Select an international character set		
0x1B 0x56	<ESC V>	195
Set 90° rotated print mode		
0x1B 0x74	<ESC t>	196
Select character code table		
0x1B 0x7B	<ESC {>	198
Turn upside-down printing mode on or off		
0x1B 0xC1		199
Select character pitch		



0x1C 0x25	<FS %>	200
Select the font type		
0x1D 0x21	<GS !>	201
Select character size		
0x1D 0x42	<GS B>	202
Turn black and white reverse printing mode on or off		

LINE SPACING COMMANDS

0x1B 0x30	<ESC 0>	203
Select 1/8-inch line spacing		
0x1B 0x32	<ESC 2>	204
Select 1/6-inch line spacing		
0x1B 0x33	<ESC 3>	205
Set line spacing		

PRINT COMMANDS

0x0A	<LF>	206
Print and line feed		
0x0D	<CR>	207
Print and carriage return		
0x1B 0x4A	<ESC J>	208
Print and paper feed		
0x1B 0x64	<ESC d>	209
Print and feed paper n lines		
0x1C 0x82		210
Print date		
0x1C 0x83		211
Print time		
0x1D 0x7C	<GS >	212
Set printing density		

STATUS COMMANDS

0x10 0x04	<DLE EOT>	213
Real-time status transmission		
0x1C 0xEA		219
Transmit the device serial number		



0x1D 0xE0	220
Enable or disable automatic FULL STATUS BACK		
0x1D 0xE1	221
Reading of length paper available before virtual paper-end		
0x1D 0xE2	222
Reading number of cuts performed by the autocutter		
0x1D 0xE3	223
Reading of length of printed paper		
0x1D 0xE5	224
Reading number of power up		

BIT-IMAGE COMMANDS

0x1B 0x2A <ESC *>	225
Select bit image mode		
0x1C 0x70 <FS p>	227
Print NV bit image		
0x1C 0x71 <FS q>	229
Define NV bit image		
0x1D 0x2A <GS *>	231
Define received bit image		
0x1D 0x2F <GS />	233
Print received bit image		
0x1D 0x76 0x30 <GS v 0>	234
Print raster bit image		

PRINT POSITION COMMANDS

0x08 <BS>	236
Back space		
0x09 <HT>	237
Horizontal tab		
0x1B 0x24 <ESC \$>	238
Set absolute print position		
0x1B 0x28 0x76 <ESC (v>	239
Set relative vertical print position		
0x1B 0x44 <ESC D>	240
Set horizontal tab positions		
0x1B 0x5C <ESC \>	242
Set relative print position		



0x1B 0x61 <ESC a>	243
Select justification		
0x1D 0x4C <GS L>	244
Set left margin		
0x1D 0x57 <GS W>	245
Set printing area width		

MACRO FUNCTIONS CONTROL

0x1D 0x3A <GS :>	246
Start or end of macro definition		
0x1D 0x5E <GS ^>	247
Execute macro		

COMMANDS FOR MECHANISM CONTROL

0x1B 0x69 <ESC i>	248
Total cut		
0x1B 0x6D <ESC m>	249
Partial cut		
0x1C 0xC0 0x34	250
Total cut and automatic paper moving back		
0x1D 0x56 <GS V>	251
Select cut mode		

ALIGNMENT COMMANDS

0x1D 0xE7	252
Set black mark distance		
0x1D 0xF6	254
Align the ticket with the printhead		
0x1D 0xF8	255
Align the ticket with the autocutter		

EJECTOR COMMANDS

0x1C 0x50 <FS P>	256
Ejector management		



MISCELLANEOUS COMMANDS

0x1B 0x3D	<ESC =>	262
Select peripheral device		
0x1B 0x40	<ESC @>	263
Initialize device		
0x1B 0x63 0x35	<ESC c 5>	264
Enable or disable keys panel		
0x1C 0x3C	<FS <>	265
Change emulation		
0x1C 0x80		266
Read date/time of the real time clock		
0x1C 0x81		267
Set date/time of the real time clock		
0x1C 0x84		268
Set user-defined date/time formats		
0x1C 0xEF		270
Set device in low power mode		
0x1D 0x49	<GS I>	271
Transmit device ID		
0x1D 0x50	<GS P>	273
Set horizontal and vertical motion units		
0x1D 0xE6		274
Virtual paper end limit		
0x1D 0xE9		275
Set minimum ticket length		
0x1D 0xF0		276
Set print mode		



COMMANDS FOR BARCODE PRINTING

0x1D 0x28 0x6B

<GS (k>

Print two-dimensional barcode

Valid for

TG1260HIII
 TG2460HIII, TG2460HIII EJC
 TG2480HIII
 TL60III
 TL80III

[Format]

Hex	1D	28	6B	pL	pH	cn	fn
ASCII	GS	(k	pL	pH	cn	fn

[Range]

cn = 0x31, 0x51
 0x41 ≤ fn ≤ 0x45,
 0x50 ≤ fn ≤ 0x52

[Description]

Processes the data concerning two-dimensional barcode.

- Barcode type is specified by cn
- Function is specified by fn

cn	fn	FUNCTION	
0x31	0x41	Function 165	QRcode: Specify encoding scheme
0x31	0x42	Function 166	QRcode: Specify the selected version
0x31	0x43	Function 167	QRcode: Specify size of barcode
0x31	0x45	Function 169	QRcode: Specify the error correction level
0x31	0x50	Function 180	QRcode: Store the received data in the barcode save area
0x31	0x51	Function 181	QRcode: Print the barcode data
0x31	0x52	Function 182	QRcode: Transmit the barcode size in the barcode save area
0x51	0x41	Function Q65	DATAMATRIX: Set encoding scheme
0x51	0x42	Function Q66	DATAMATRIX: Set rotate
0x51	0x43	Function Q67	DATAMATRIX: Set dot size of the module
0x51	0x44	Function Q68	DATAMATRIX: Set size of barcode
0x51	0x50	Function Q80	DATAMATRIX: Store the received data in the barcode save area
0x51	0x51	Function Q81	DATAMATRIX: Print the barcode data in the barcode save area



[Notes]

[Default]

[Reference]

[Example]

0x1D 0x28 0x6B [Fn 165]

<GS (k>

Specify encoding scheme of QRcode barcode

Valid for
 TG1260HIII
 TG2460HIII, TG2460HIII EJC
 TG2480HIII
 TL60III
 TL80III

[Format] Hex 1D 28 6B pL pH 31 41 n1 n2
 ASCII GS (k pL pH 1 A n1 n2

[Range] (pL+pH × 256) = 4 (pL = 0x04, pH = 0x00)
 0x32 ≤ n1 ≤ 0x33
 n2 = 0x00

[Description] Specifies encoding type of QRcode barcode, based on the value of n1 as follows:

n1	ENCODING SCHEME
0x32	QRcode model 2
0x33	MicroQR

[Notes]

- QRcode: Encode all extended ASCII characters data up to a maximum length of 7089 numeric digits, 4296 alphabetic characters or 2953 bytes of data.
- pL and pH specify the number of successive bytes to be sent.
- MicroQR (a miniature version of the QRcode barcode for short message): Encode all numbers from 0 to 9 up to a maximum length of 35 characters.

[Default] n1 =0x32, n2 = 0x00

[Reference] [0x1D 0x28 0x6B](#)

[Example]

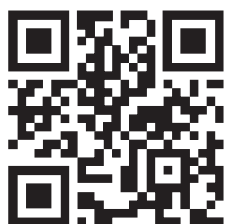

QRcode Model 2



MicroQR



0x1D 0x28 0x6B [Fn 166]

<GS (k >

Specify QRcode barcode version

Valid for	TG1260HIII TG2460HIII, TG2460HIII EJC TG2480HIII TL60III TL80III
-----------	--

[Format]	Hex 1D 28 6B pL pH 31 42 n ASCII GS (k pL pH 1 B n
----------	---

[Range]	(pL + pH × 256) = 3 (pL = 0x03, pH = 0x00) 0x00 ≤ n ≤ 0x28
---------	--

[Description]	Defines QRcode version to be printed.
---------------	---------------------------------------

- [Notes]
- If selected version has not enough capacity to store the saved amount of data, next smallest version capable of that capacity will be printed.
 - For QRcode version capacity according to ECC (Error Correction Capability) and data type refer to following table.
 - With n = 0x00 the selection of the version occurs automatically according to the one that allows the printing of the requested data.

n	VERSION	MODULES	ECC LEVEL	NUMERIC	ALPHANUMERIC	BINARY
0x00	AUTO	-	-	-	-	-
0x01	1	21 x 21	L	40	24	16
			M	33	19	13
			Q	26	15	10
			H	16	9	6
0x02	2	25 x 25	L	76	46	31
			M	62	37	25
			Q	47	28	19
			H	33	19	13
0x03	3	29 x 29	L	126	76	52
			M	100	60	41
			Q	76	46	31
			H	57	34	23
0x04	4	33 x 33	L	186	113	77
			M	148	89	61
			Q	110	66	45
			H	81	49	33
0x05	5	37 x 37	L	254	153	105
			M	201	121	83
			Q	143	86	59
			H	105	63	43



n	VERSION	MODULES	ECC LEVEL	NUMERIC	ALPHANUMERIC	BINARY
0x06	6	41 x 41	L	321	194	133
			M	254	153	105
			Q	177	107	73
			H	138	83	57
0x07	7	45 x 45	L	369	223	153
			M	292	177	121
			Q	206	124	85
			H	153	92	63
0x08	8	49 x 49	L	460	278	191
			M	364	220	151
			Q	258	156	107
			H	201	121	83
0x09	9	53 x 53	L	551	334	229
			M	431	261	179
			Q	311	188	129
			H	234	142	97
0x0A	10	57 x 57	L	651	394	270
			M	512	310	212
			Q	363	220	150
			H	287	173	118
0x0B	11	61 x 61	L	771	467	320
			M	603	365	250
			Q	426	258	176
			H	330	199	136
0x0C	12	65 x 65	L	882	534	366
			M	690	418	286
			Q	488	295	202
			H	373	226	154
0x0D	13	69 x 69	L	1021	618	424
			M	795	482	330
			Q	579	351	240
			H	426	258	176
0x0E	14	73 x 73	L	1100	666	457
			M	870	527	361
			Q	620	375	257
			H	467	282	193
0x0F	15	77 x 77	L	1249	757	519
			M	990	599	411
			Q	702	425	291
			H	529	320	219
0x10	16	81 x 81	L	1407	853	585
			M	1081	655	449
			Q	774	469	321
			H	601	364	249
0x11	17	85 x 85	L	1547	937	643
			M	1211	733	503
			Q	875	530	363
			H	673	407	279
0x12	18	89 x 89	L	1724	1045	717
			M	1345	815	559
			Q	947	573	393
			H	745	451	309



n	VERSION	MODULES	ECC LEVEL	NUMERIC	ALPHANUMERIC	BINARY
0x13	19	93 x 93	L	1902	1152	791
			M	1499	908	623
			Q	1062	643	441
			H	812	492	337
0x14	20	97 x 97	L	2060	1248	857
			M	1599	969	665
			Q	1158	701	481
			H	918	556	381
0x15	21	101 x 101	L	2231	1351	928
			M	1707	1034	710
			Q	1223	741	508
			H	968	586	402
0x16	22	105 x 105	L	2408	1459	1002
			M	1871	1133	778
			Q	1357	822	564
			H	1055	639	438
0x17	23	109 x 109	L	2619	1587	1090
			M	2058	1247	856
			Q	1467	889	610
			H	1107	671	460
0x18	24	113 x 113	L	2811	1703	1170
			M	2187	1325	90
			Q	1587	92	60
			H	1227	73	50
0x19	25	117 x 117	L	3056	1852	1272
			M	2394	1450	96
			Q	1717	1040	74
			H	1285	78	54
0x1A	26	121 x 121	L	3282	198	1366
			M	2543	1541	1058
			Q	1803	1093	70
			H	1424	83	52
0x1B	27	125 x 125	L	3516	2131	1464
			M	2700	1636	1124
			Q	1932	1171	84
			H	1500	89	64
0x1C	28	129 x 129	L	3668	2222	1527
			M	2856	1731	118
			Q	2084	1262	87
			H	1580	97	67
0x1D	29	133 x 133	L	3908	2368	1627
			M	3034	1838	1263
			Q	2180	1321	97
			H	1676	1015	67
0x1E	30	137 x 137	L	4157	251	1731
			M	3288	1993	136
			Q	2357	1428	91
			H	1781	107	71
0x1F	31	141 x 141	L	4416	2676	183
			M	3485	2112	1451
			Q	2472	1498	102
			H	1896	114	69



n	VERSION	MODULES	ECC LEVEL	NUMERIC	ALPHANUMERIC	BINARY
0x20	32	145 x 145	L	4685	283	1951
			M	3692	2237	1537
			Q	266	1617	1111
			H	2021	1225	81
0x21	33	149 x 149	L	4964	3008	2067
			M	3908	2368	1627
			Q	2804	16	1167
			H	2156	1306	87
0x22	34	153 x 153	L	5252	3182	2187
			M	4133	2505	1721
			Q	2948	1786	1227
			H	2300	1393	97
0x23	35	157 x 157	L	5528	3350	2302
			M	4342	2631	1808
			Q	3080	1866	1282
			H	2360	1430	92
0x24	36	161 x 161	L	5835	3536	2430
			M	4587	277	1910
			Q	3243	1965	1350
			H	2523	152	1050
0x25	37	165 x 165	L	6152	3728	2562
			M	4774	2893	1988
			Q	3416	2070	1422
			H	2624	1590	1092
0x26	38	169 x 169	L	6478	3926	2698
			M	5038	3053	2098
			Q	3598	2180	1498
			H	2734	1657	1138
0x27	39	173 x 173	L	6742	4086	2808
			M	5312	321	2212
			Q	3790	2297	1578
			H	2926	1773	1218
0x28	40	177 x 177	L	7088	4295	2952
			M	5595	3390	2330
			Q	3992	241	1662
			H	3056	1851	1272

[Default] n = 0x00

[Reference] [0x1D 0x28 0x6B](#)

[Example] To select QRcode version 8 the command sequence is:
0x1D 0x28 0x6B 0x03 0x00 0x31 0x42 0x08

0x1D 0x28 0x6B [Fn 167]

<GS (k>

Specify dot size of the module of the QRcode barcode

Valid for	TG1260HIII TG2460HIII, TG2460HIII EJC TG2480HIII TL60III TL80III
-----------	--

[Format]	Hex	1D	28	6B	pL	pH	31	43	n
	ASCII	GS	(k	pL	pH	1	C	n

[Range] (pL + pH × 256) = 3 (pL = 0x03, pH = 0x00)
0x02 ≤ n ≤ 0x18

[Description] Specifies numbers of dots for each pixel of QRcode barcode.

[Notes] pL and pH specify the number of successive bytes to be sent.

[Default] n = 0x06

[Reference] [0x1D 0x28 0x6B](#)

[Example]

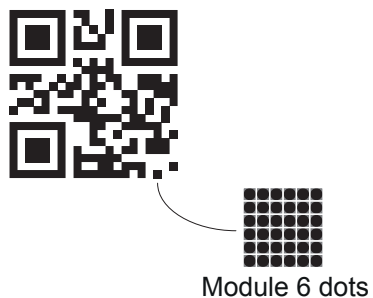



0x1D 0x28 0x6B [Fn 180]

<GS (k>

Store the data in the barcode save area for printing in QRcode format

Valid for	TG1260HIII TG2460HIII, TG2460HIII EJC TG2480HIII TL60III TL80III									
[Format]	Hex	1D	28	6B	pL	pH	31	50	31	d1...dk
	ASCII	GS	(k	pL	pH	1	P	1	d1...dk
[Range]	$0x00 \leq d \leq 0xFF$ $k = (pL + pH \times 256) - 3$ <ul style="list-style-type: none"> QRcode barcode only with binary characters (8 bit): $4 \leq (pL + pH \times 256) \leq 2957$ (0x00 ≤ pL ≤ 0xFF, 0x00 ≤ pH ≤ 0x0B) QRcode barcode only with alphanumeric characters: $4 \leq (pL + pH \times 256) \leq 4300$ (0x00 ≤ pL ≤ 0xFF, 0x00 ≤ pH ≤ 0x10) QRcode barcode only with numeric characters: $4 \leq (pL + pH \times 256) \leq 7093$ (0x00 ≤ pL ≤ 0xFF, 0x00 ≤ pH ≤ 0x1B) 									
[Description]	Store the data (d1...dk) in the barcode save area for printing in QRcode format.									
[Notes]	<ul style="list-style-type: none"> Data stored in the barcode save area by this function are processed by Function 181 and then reserved. pL and pH specify the number of successive bytes to be sent. k bytes of d1...dk are processed as barcode data. Specify only the data code word of the barcode with this function. 									
[Default]										
[Reference]	0x1D 0x28 0x6B									
[Example]										



0x1D 0x28 0x6B [Fn 181]

<GS (k>

Prints the data stored in the barcode save area in QRcode format

Valid for

- TG1260HIII
- TG2460HIII, TG2460HIII EJC
- TG2480HIII
- TL60III
- TL80III

[Format]

Hex	1D	28	6B	pL	pH	31	51	31
ASCII	GS	(k	pL	pH	1	Q	1

[Range] (pL + pH × 256) = 3 (pL = 0x03, pH = 0x00)

[Description] Prints the data stored in the barcode save area in QRcode format.

[Notes] pL and pH specify the number of successive bytes to be sent.

[Default]

[Reference] [0x1D 0x28 0x6B](#)

[Example]



0x1D 0x28 0x6B [Fn 182]

<GS (k>

Transmit the QRcode barcode size in the barcode save area

Valid for	TG1260HIII TG2460HIII, TG2460HIII EJC TG2480HIII TL60III TL80III
-----------	--

[Format]	Hex 1D 28 6B pL pH 31 52 30 ASCII GS (k pL pH 1 R 0
----------	--

[Range] (pL+pH × 256) = 3 (pL = 0x03, pH = 0x00)

[Description] Transmits the QRcode barcode size in the barcode save area.

- [Notes]
- To store the data in the device barcode save area use the [Function 180](#).
 - In standard mode, use this function when device is at the beginning of a line or when there is no data in the print buffer.
 - pL and pH specify the number of successive bytes to be sent.
 - The size information for each data is as follows:

SEND DATA	HEX	DATA
Header	37	1 byte
Identifier	36	1 byte
Horizontal size ⁽¹⁾	30-39	1 - 5 byte
Separator	1F	1 byte
Vertical size ⁽¹⁾	30-39	1 - 5 byte
Separator	1F	1 byte
Fixed value	31	1 byte
Separator	1F	1 byte
Other information ⁽²⁾	30 or 31	1 byte
NUL	00	1 byte

(1) "Horizontal size" and "vertical size" indicate the number of dots of the symbol.
The values of the vertical size and horizontal size are converted to characters and sent starting from the high order end (ex: When horizontal size is 120 dots, horizontal size is 0x31 0x32 0x30, which is 3 bytes of data).

(2) "Other information" indicates whether printing of the data in the symbol storage area is possible or impossible. The "Other information" is the following:

HEX	CONDITION
30	Printing is possible
31	Printing is impossible



- Size information indicates size of symbol that is printed by [Function 181](#).
- The quiet zone is not included in the size information.
- If “other information” is “Printing is impossible“(0x31), use one of the solutions shown below:

CAUSE	SOLUTION
There are data in the print buffer in the standard mode	Clear the data in the print buffer by executing 0x0A , 0x0D , 0x1B 0x4A print commands.
Symbol is bigger than the current print area.	Expand the print area by 0x1D 0x57 , 0x1B 0x24 . Reduce the module size by using Function 167 . Lower the error correction level by using Function 169 .
The data in the symbol storage area is too large.	Send correct data by using Function 180 . Lower the error correction level by using Function 169 .
There is no data in the symbol storage area.	Send data to the symbol storage area by using Function 180 .

[Default]

[Reference]

[0x1D](#) [0x28](#) [0x6B](#)

[Example]

A possible device response can be:

[0x37](#) [0x36](#) [0x31](#) [0x32](#) [0x36](#) [0x1F](#) [0x31](#) [0x32](#) [0x36](#) [0x1F](#) [0x31](#) [0x1F](#) [0x30](#) [0x00](#)

where:

0x37	header
0x36	identifier
0x31 0x32 0x36	horizontal size 126 dots (0x31 = 1, 0x32 = 2, 0x36 = 6)
0x1F	separator
0x31 0x32 0x36	vertical size 126 dots (0x31 = 1, 0x32 = 2, 0x36 = 6)
0x1F	separator
0x31	fixed value
0x1F	separator
0x30	printing possible
0x00	NUL (end of text character)



0x1D 0x28 0x6B [Fn Q65]

<GS (k>

Specify the encoding scheme of DATAMATRIX barcode

Valid for	TG1260HIII TG2460HIII, TG2460HIII EJC TG2480HIII TL60III TL80III
-----------	--

[Format]	Hex	1D	28	6B	pL	pH	51	41	n
	ASCII	GS	(k	pL	pH	Q	A	n

[Range]	(pL + pH × 256) = 3	(pL = 0x03, pH = 0x00)
	0x00 ≤ n ≤ 0x06	

[Description] Set the encoding scheme for the DATAMATRIX barcode based on the value of n as follows:

n	ENCODING
0x00	ASCII
0x01	C40
0x02	Text
0x03	X12
0x04	Edifact
0x05	Base256
0x06	AutoBest

[Notes] pL and pH specify the number of successive bytes to be sent.

[Default]

[Reference] [0x1D 0x28 0x6B](#)

[Example] To set encoding = ASCII, the command sequence is:
0x1D 0x28 0x6B 0x03 0x00 0x51 0x41 0x00



0x1D 0x28 0x6B [Fn Q66]

<GS (k>

Set rotation of DATAMATRIX barcode

Valid for TG1260HIII
 TG2460HIII, TG2460HIII EJC
 TG2480HIII
 TL60III
 TL80III

[Format] Hex 1D 28 6B pL pH 51 42 n
 ASCII GS (k pL pH Q B n

[Range] (pL + pH × 256) = 3 (pL = 0x03, pH = 0x00)
 n = 0x00, 0x01

[Description] Set the rotation for the DATAMATRIX barcode based on the value of n as follows:

n	ROTATION
0x00	No rotation
0x01	Rotation

[Notes] pL and pH specify the number of successive bytes to be sent.

[Default]

[Reference] [0x1D 0x28 0x6B](#)

[Example]



0x1D 0x28 0x6B [Fn Q67]

<GS (k>

Set dot size of the module of DATAMATRIX barcode

Valid for	TG1260HIII TG2460HIII, TG2460HIII EJC TG2480HIII TL60III TL80III								
-----------	--	--	--	--	--	--	--	--	--

[Format]	Hex	1D	28	6B	pL	pH	51	43	n
	ASCII	GS	(k	pL	pH	Q	C	n

[Range] (pL + pH × 256) = 3 (pL = 0x03, pH = 0x00)
0x02 ≤ n ≤ 0x18

[Description] Set dot size of the module of the DATAMATRIX barcode:
n = dot dimension

[Notes] pL and pH specify the number of successive bytes to be sent.

[Default] n = 0x06

[Reference] [0x1D 0x28 0x6B](#)

[Example] To set dot size = 6 the command sequence is:
0x1D 0x28 0x6B 0x03 0x00 0x51 0x43 0x06



0x1D 0x28 0x6B [Fn Q68]

<GS (k >

Set size of DATAMATRIX barcode

Valid for TG1260HIII
TG2460HIII, TG2460HIII EJC
TG2480HIII
TL60III
TL80III

[Format] Hex 1D 28 6B pL pH 51 44 n
ASCII GS (k pL pH Q D n

[Range] (pL + pH × 256) = 3 (pL = 0x03, pH = 0x00)
0x00 ≤ n ≤ 0x1D

[Description] Set the size of DATAMATRIX barcode based on the value of n as follows:

n	BARCODE SIZE	n	BARCODE SIZE
0x00	AUTO	0x0F	52 x 52
0x01	10 x 10	0x10	64 x 64
0x02	12 x 12	0x11	72 x 72
0x03	14 x 14	0x12	80 x 80
0x04	16 x 16	0x13	88 x 88
0x05	18 x 18	0x14	96 x 96
0x06	20 x 20	0x15	104 x 104
0x07	22 x 22	0x16	120 x 120
0x08	24 x 24	0x17	132 x 132
0x09	26 x 26	0x18	144 x 144
0x0A	32 x 32	0x19	8 x 18
0x0B	36 x 36	0x1A	8 x 32
0x0C	40 x 40	0x1B	12 x 26
0x0D	44 x 44	0x1C	12 x 36
0x0E	48 x 48	0x1D	16 x 36

[Notes] pL and pH specify the number of successive bytes to be sent.

[Default] n = 0x00

[Reference] [0x1D 0x28 0x6B](#)

[Example]



0x1D 0x28 0x6B [Fn Q80]

<GS (k)>

Store the DATAMATRIX barcode data in the barcode save area

Valid for	TG1260HIII TG2460HIII, TG2460HIII EJC TG2480HIII TL60III TL80III									
[Format]	Hex	1D	28	6B	pL	pH	51	50	33	d1...dk
	ASCII	GS	(k	pL	pH	Q	P	3	d1...dk
[Range]	<p>$0x00 \leq d \leq 0xFF$ $k = (pL + pH \times 256) - 3$</p> <ul style="list-style-type: none"> DATAMATRIX barcode only with ASCII characters (8 bit) : $4 \leq (pL + pH \times 256) \leq 1560$ ($0x00 \leq pL \leq 0xFF$, $0x00 \leq pH \leq 0x06$) DATAMATRIX barcode only with alphanumeric characters: $4 \leq (pL + pH \times 256) \leq 2339$ ($0x00 \leq pL \leq 0xFF$, $0x00 \leq pH \leq 0x09$) DATAMATRIX barcode only with numeric characters: $4 \leq (pL + pH \times 256) \leq 3120$ ($0x00 \leq pL \leq 0xFF$, $0x00 \leq pH \leq 0x0C$) 									
[Description]	Store the DATAMATRIX barcode data (d1...dk) in the barcode save area.									
[Notes]	<ul style="list-style-type: none"> Data stored in the barcode save area by this function are processed by Function Q81 and then reserved. pL and pH specify the number of successive bytes to be sent. k bytes of d1...dk are processed as barcode data. Specify only the data code word of the barcode with this function. Be sure not to include the control data in the data d1...dk because they are added automatically by the device. 									
[Default]										
[Reference]	0x1D 0x28 0x6B									
[Example]										



0x1D 0x28 0x6B [Fn Q81]

<GS (k>

Encodes and prints the data stored in the barcode save area in DATAMATRIX format

Valid for	TG1260HIII TG2460HIII, TG2460HIII EJC TG2480HIII TL60III TL80III								
[Format]	Hex	1D	28	6B	pL	pH	51	51	33
	ASCII	GS	(k	pL	pH	Q	Q	3
[Range]	(pL + pH × 256) = 3 (pL = 0x03, pH = 0x00)								
[Description]	Encodes and prints the data stored in the barcode save area in DATAMATRIX format.								
[Notes]	<ul style="list-style-type: none"> • In standard mode, use this function when device is at the beginning of a line or there is no data in the print buffer. • pL and pH specify the number of successive bytes to be sent. • A barcode that size exceeds the printing area cannot be printed. • If there is any error described below in the data of the barcode save area, it cannot be printed. <ul style="list-style-type: none"> - There is no data (Function Q80 is not processed). - If [(number of columns × number of rows) < number of code word] when auto processing is specified for number of columns and number of rows. - Number of code word exceeds 928 in the data area. • When auto processing (Function Q65) is specified, the number of columns is calculated by the current printing area, module width (Function Q67) and the code word in the data area. Maximum number of the columns is 30. 								
[Default]									
[Reference]	0x1D 0x28 0x6B								
[Example]	To print the DATAMATRIX barcode data the command sequence is: 0x1D 0x28 0x6B 0x03 0x00 0x51 0x51 0x33								



0x1D 0x48

<GS H>

Select printing position of HRI characters in 1D barcodes

Valid for	TG1260HIII TG2460HIII, TG2460HIII EJC TG2480HIII TL60III TL80III
-----------	--

[Format]	Hex 1D 48 n
	ASCII GS H n

[Range]	0x00 ≤ n ≤ 0x03 0x30 ≤ n ≤ 0x33
---------	------------------------------------

[Description] Selects the print position of HRI (Human Readable Interpretation) characters when printing a 1D barcode, based on the value of n as follows:

n	FUNCTION
0x00, 0x30	Not printed
0x01, 0x31	Above the barcode
0x02, 0x32	Below the barcode
0x03, 0x33	Both above and below the barcode

[Notes] HRI characters are printed using the font specified by [0x1D 0x66](#).

[Default] n = 0x00

[Reference] [0x1D 0x66](#), [0x1D 0x6B](#)



[Example]

Not printed

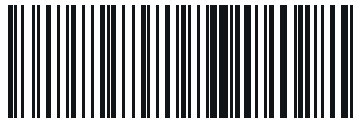

Above the barcode

ABCDEFGH123456

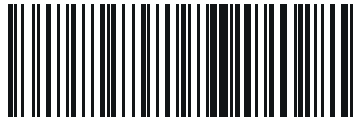

Below the barcode

ABCDEFGH123456

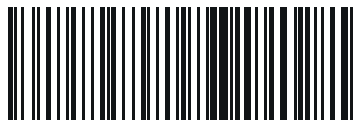

Both above and below the barcode

ABCDEFGH123456

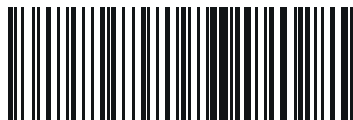

ABCDEFGH123456



0x1D 0x66

<GS f>

Select font for HRI characters

Valid for TG1260HIII
TG2460HIII, TG2460HIII EJC
TG2480HIII
TL60III
TL80III

[Format] Hex 1D 66 n
ASCII GS f n

[Range] n = 0x00, 0x01, 0x30, 0x31

[Description] Selects a font for the HRI (Human Readable Interpretation) characters used when printing a 1D barcode, based on the value of n as follows:

n	FONT
0x00, 0x30	Font A
0x01, 0x31	Font B

[Notes] HRI characters are printed at the position specified by [0x1D 0x48](#).

[Default] n = 0x00

[Reference] [0x1D 0x48](#), [0x1D 0x6B](#)

[Example]

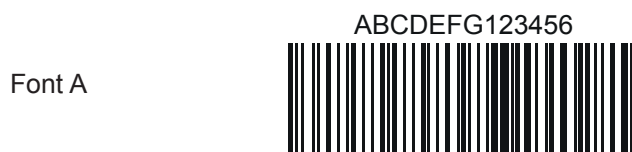



0x1D 0x68

<GS h>

Set 1D barcode height

Valid for

- TG1260HIII
- TG2460HIII, TG2460HIII EJC
- TG2480HIII
- TL60III
- TL80III

[Format]

Hex	1D	68	n
ASCII	GS	h	n

[Range] $0x01 \leq n \leq 0xFF$

[Description] Sets the height of the 1D barcode.
n specifies the number of vertical dots.

[Notes]

[Default] n = 0xA2 (20.25 mm)

[Reference] [0x1D 0x6B](#)

[Example] To print a barcode with height of 15 mm, the command sequence is:
0x1D 0x68 0x78

Where:

15 mm = 15 × 8 dots = 120 dots which converted in hexadecimal value = 0x78



0x1D 0x6B

<GS k>

Print 1D barcode

Valid for	TG1260HIII TG2460HIII, TG2460HIII EJC TG2480HIII TL60III TL80III					
-----------	--	--	--	--	--	--

[Format 1]	Hex	1D	6B	m	[d1..dk]	00
	ASCII	GS	k	m	[d1..dk]	NUL

[Format 2]	Hex	1D	6B	m	n	[d1..dn]
	ASCII	GS	k	m	n	[d1..dn]

[Range]	Format 1	0x00 ≤ m ≤ 0x08,	m = 0x14
	Format 2	0x41 ≤ m ≤ 0x49,	m = 0x5A

[Description] Selects a 1D barcode system and prints the 1D barcode based on the value of m as follows:

Format 1

m	BARCODE SYSTEM	NUMBER OF CHARACTERS	REMARKS
0x00	UPC-A	0x0B ≤ k ≤ 0x0C	0x30 ≤ d ≤ 0x39
0x01	UPC-E	0x0B ≤ k ≤ 0x0C	0x30 ≤ d ≤ 0x39
0x02	EAN13 (JAN)	0x0C ≤ k ≤ 0x0D	0x30 ≤ d ≤ 0x39
0x03	EAN8 (JAN)	0x07 ≤ k ≤ 0x08	0x30 ≤ d ≤ 0x39
0x04	CODE39	0x01 ≤ k	0x30 ≤ d ≤ 0x39, 0x41 ≤ d ≤ 0x5A, 0x20, 0x24, 0x25, 0x2B, 0x2D, 0x2E, 0x2F
0x05	ITF	0x01 ≤ k (even number)	0x30 ≤ d ≤ 0x39
0x06	CODABAR	0x01 ≤ k	0x30 ≤ d ≤ 0x39, 0x41 ≤ d1 ≤ 0x44, 0x24, 0x2B, 0x2D, 0x2E, 0x2F, 0x3A
0x07	CODE93	0x01 ≤ k ≤ 0xFF	0x01 ≤ d ≤ 0x7F
0x08	CODE128	0x02 ≤ k ≤ 0xFF	0x01 ≤ d ≤ 0x7F
0x14	CODE32	0x08 ≤ k ≤ 0x09	0x30 ≤ d ≤ 0x39



Format 2

m	BARCODE SYSTEM	NUMBER OF CHARACTERS	REMARKS
0x41	UPC-A	0x0B ≤ n ≤ 0x0C	0x30 ≤ d ≤ 0x39
0x42	UPC-E	0x0B ≤ n ≤ 0x0C	0x30 ≤ d ≤ 0x39
0x43	EAN13 (JAN)	0x0C ≤ n ≤ 0x0D	0x30 ≤ d ≤ 0x39
0x44	EAN8 (JAN)	0x07 ≤ n ≤ 0x08	0x30 ≤ d ≤ 0x39
0x45	CODE39	0x01 ≤ n ≤ 0xFF	0x30 ≤ d ≤ 0x39, 0x41 ≤ d ≤ 0x5A, 0x20, 0x24, 0x25, 0x2B, 0x2D, 0x2E, 0x2F
0x46	ITF	0x01 ≤ n ≤ 0xFF	0x30 ≤ d ≤ 0x39
0x47	CODABAR	0x01 ≤ n ≤ 0xFF	0x30 ≤ d ≤ 0x39, 0x41 ≤ d1 ≤ 0x44, 0x24, 0x2B, 0x2D, 0x2E, 0x2F, 0x3A
0x48	CODE93	0x01 ≤ n ≤ 0xFF	0x01 ≤ d ≤ 0x7F
0x49	CODE128	0x02 ≤ n ≤ 0xFF	0x01 ≤ d ≤ 0x7F
0x5A	CODE32	0x08 ≤ n ≤ 0x09	0x30 ≤ d ≤ 0x39

[Notes]

- If d is outside of the specified range, the device prints the following message: "BARCODE GENERATOR IS NOT OK!" and processes the data which follows as normal data.
- If the horizontal size exceeds the printing area, the device only feeds the paper.
- This command feeds as much paper as is required to print the barcode, regardless of the line spacing specified by [0x1B 0x32](#) or [0x1B 0x33](#).
- After printing the barcode, this command sets the print position to the beginning of the line.
- This command is not affected by print modes (bold, double-strike, underline or character size), except for upside-down and justification mode.

Format 1

- This command ends with a NUL code.
- When the barcode system used is UPC-A or UPC-E, the device prints the barcode data after receiving 11 (without check digit) or 12 (with check digit) bytes barcode data.
- When the barcode system used is EAN13, the device prints the barcode data after receiving 12 (without check digit) or 13 (with check digit) bytes barcode data.
- When the barcode system used is EAN8, the device prints the barcode data after receiving 7 (without check digit) or 8 (with check digit) bytes barcode data.
- The number of data for ITF barcode must be even numbers. When an odd number of data is input, the device ignores the last received data.

Format 2

If n is outside of the specified range, the device stops command processing and processes the following data as normal data.

When CODE93 is used:

- The device prints an HRI character (o) as a start character at the beginning of the HRI character string.



- The device prints an HRI character (o) as a stop character at the end of the HRI character string.
- The device prints an HRI character (n) as a control character (0x00 to 0x1F and 0x7F).

When CODE128 is used, please note the following regarding data transmission:

- The top part of the barcode data string must be a code set selection character (CODE A, CODE B or CODE C) which selects the first code set.
- Special characters are defined by combining two characters “{” and one character. ASCII character “{” is defined by transmitting “{{” twice, consecutively.

SPECIFIC CHARACTER	DATA TRANSMISSION	
	ASCII	HEX
SHIFT	{S	7B, 53
CODE A	{A	7B, 41
CODE B	{B	7B, 42
CODE C	{C	7B, 43
FNC1	{1	7B, 31
FNC2	{2	7B, 32
FNC3	{3	7B, 33
FNC4	{4	7B, 34
{“	{{	7B, 7B

When UPC-E is used, introducing the barcode characters, the device prints:

TRANSMITTED DATA											PRINTED DATA					
d1	d2	d3	d4	d5	d6	d7	d8	d9	d10	d11	d2	d3	d9	d10	d11	
0	0-9	0-9	0	0	0	0	0	0-9	0-9	0-9	d2	d3	d9	d10	d11	0
0	0-9	0-9	1	0	0	0	0	0-9	0-9	0-9	d2	d3	d9	d10	d11	1
0	0-9	0-9	2	0	0	0	0	0-9	0-9	0-9	d2	d3	d9	d10	d11	2
0	0-9	0-9	3-9	0	0	0	0	0	0-9	0-9	d2	d3	d4	d10	d11	3
0	0-9	0-9	0-9	1-9	0	0	0	0	0	0-9	d2	d3	d4	d5	d11	4
0	0-9	0-9	0-9	0-9	1-9	0	0	0	0	5-9	d2	d3	d4	d5	d6	d11

[Default]

[Reference]

0x1D 0x48, 0x1D 0x68, 0x1D 0x77

[Example]

Format 1: Example for printing a CODE39 barcode:
0x1D 0x6B 0x04 0x54 0x45 0x53 0x54 0x00

Format 2: Example for printing a CODE39 barcode:
0x1D 0x6B 0x45 0x04 0x54 0x45 0x53 0x54



0x1D 0x77

<GS w>

Set 1D barcode width

Valid for TG1260HIII
 TG2460HIII, TG2460HIII EJC
 TG2480HIII
 TL60III
 TL80III

[Format] Hex 1D 77 n
 ASCII GS w n

[Range] $0x01 \leq n \leq 0x06$

[Description] Sets the horizontal size of the 1D barcode. n specifies the barcode width as follows:

n	MODULE WIDTH (mm)
0x01	0.125
0x02	0.25
0x03	0.375
0x04	0.5
0x05	0.625
0x06	0.75

	n	WIDE BAR / NARROW BAR RATIO
If n < 0x80	0x01, 0x02, 0x03, 0x04, 0x05, 0x06	3:1
	0x81	3:1
If n > 0x80	0x82	2.5:1
	0x83	2.33:1
	0x84	2.25:1
	0x85	3:1
	0x86	3:1

[Notes] This command is enabled only when inserted at the beginning of a line.



[Default] n = 0x03

[Reference] 0x1D 0x6B

[Example]

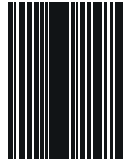

n = 0x01

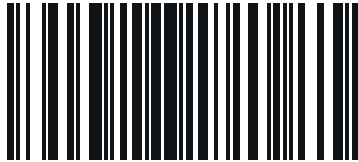

n = 0x03



CHARACTER COMMANDS

0x18

<CAN>

Cancel current line transmitted

Valid for	TG1260HIII
	TG2460HIII, TG2460HIII EJC
	TG2480HIII
	TL60III
	TL80III

[Format]	Hex	18
	ASCII	CAN

[Range]

[Description] Deletes current line transmitted.

- [Notes]
- Sets the print position to the beginning of the line.
 - This command does not clear the receive buffer.

[Default]

[Reference]

[Example]

0x1B 0x20

<ESC SP>

Set right-side character spacing

Valid for	TG1260HIII TG2460HIII, TG2460HIII EJC TG2480HIII TL60III TL80III
-----------	--

[Format]	Hex 1B 20 n
	ASCII ESC SP n

[Range] 0x00 ≤ n ≤ 0xFF

[Description] Sets the character spacing for the right side of the character to [n × horizontal or vertical motion units].

- [Notes]
- The right character spacing for double-width mode is twice the normal value. When the characters are enlarged, the right side character spacing is m (2 or 4) times the normal value.
 - The horizontal and vertical motion units are specified by **0x1D 0x50**. Changing the horizontal or vertical motion units does not affect the current right side spacing.
 - The **0x1D 0x50** command can change the horizontal (and vertical) motion unit. However, the value cannot be less than the minimum horizontal movement amount.
 - The maximum right side spacing is 32 mm.
 - In standard mode, the horizontal motion unit is used.

[Default] n = 0x00

[Reference] **0x1D 0x50**

[Example]

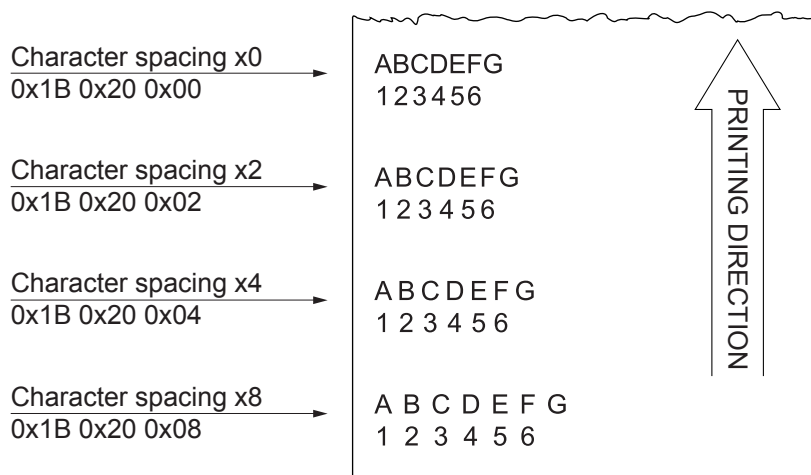



0x1B 0x21

<ESC !>

Select print modes

Valid for

TG1260HIII
 TG2460HIII, TG2460HIII EJC
 TG2480HIII
 TL60III
 TL80III

[Format]

Hex	1B	21	n
ASCII	ESC	!	n

[Range] 0x00 ≤ n ≤ 0xFF

[Description] Selects print modes based on the value of n as follows:

BIT	OFF/ON	n	FUNCTION	11/15 dpi	15/20 dpi	20/25 dpi
0	Off	0x00	Character font A selected	18 x 24	14 x 24	10 x 24
	On	0x01	Character font B selected	14 x 24	10 x 24	8 x 24
1	-	-	Undefined			
2	-	-	Undefined			
3	Off	0x00	Bold mode not selected			
	On	0x08	Blod mode selected			
4	Off	0x00	Double-height mode not selected			
	On	0x10	Double-height mode selected			
5	Off	0x00	Double-width mode not selected			
	On	0x20	Double-width mode selected			
6	Off	0x00	Italic mode not selected			
	On	0x40	Italic mode selected			
7	Off	0x00	Underlined mode not selected			
	On	0x80	Underlined mode selected			

- [Notes]
- The device can underline all characters, but cannot underline the spaces set by [0x09](#), [0x1B 0x24](#), [0x1B 0x5C](#) and 90°/270° rotated characters.
 - This command resets the left and right margin at default value (see [0x1D 0x4C](#), [0x1D 0x57](#)).
 - [0x1B 0x45](#) can also be used to turn the bold mode on or off. However, the last-received setting command is the effective one.
 - [0x1B 0x2D](#) can also be used to turn the underlining mode on or off. However, the last-received setting command is the effective one.
 - [0x1D 0x21](#) can also be used to select character height or width. However, the last-received setting command is the effective one.
 - [0x1B 0x34](#) can also be used to turn the italic mode on or off. However, the last-received setting command is the effective one.



• Commands that change the height and width of characters are effective on the x and y axes. In case of 90°/270° rotated characters, command 0x1B 0x21 0x10 selects double-width mode and command 0x1B 0x21 0x20 selects double-height mode.

[Default] n = 0x00

[Reference] 0x1B 0x2D, 0x1B 0x45, 0x1D 0x21, 0x1B 0x34

[Example]

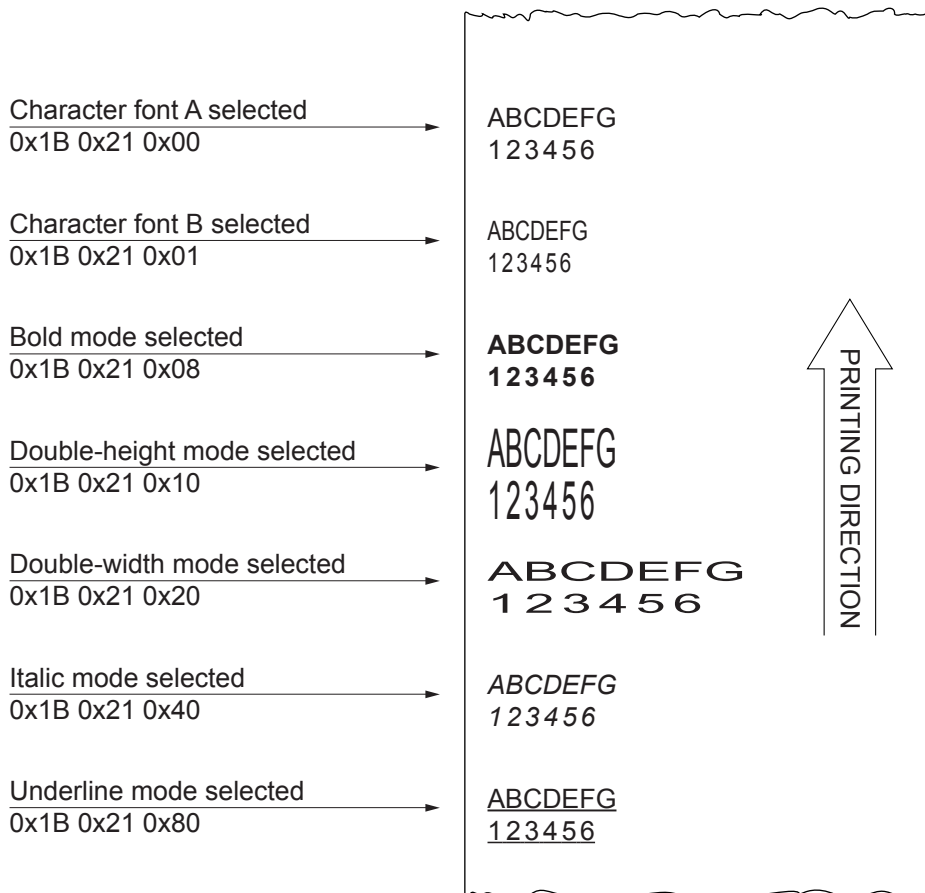



0x1B 0x25

<ESC %>

Enable or disable user-defined characters

Valid for TG1260HIII
TG2460HIII, TG2460HIII EJC
TG2480HIII
TL60III
TL80III

[Format] Hex 1B 25 n
ASCII ESC % n

[Range] $0x00 \leq n \leq 0xFF$

[Description] Enables or disables the user-defined character set.
When the Least Significant Bit (LSB) of n is 0, the user-defined character set is disabled.
When the Least Significant Bit (LSB) of n is 1, the user-defined character set is enabled.

[Notes]

- Only the Least Significant Bit (LSB) of n is applicable.
- When the user-defined character set is disabled, the internal character set is automatically selected.

[Default] n = 0x00

[Reference] [0x1B 0x26](#), [0x1B 0x3F](#)

[Example]



0x1B 0x26

<ESC &>

Defines user-defined characters

Valid for	TG1260HIII TG2460HIII, TG2460HIII EJC TG2480HIII TL60III TL80III						
[Format]	Hex	1B	26	y	c1	cn	x1[d0...dk] ... xn[d0...dk]
	ASCII	ESC	&	y	c1	cn	x1[d0...dk] ... xn[d0...dk]
[Range]	y = 0x03 0x20 ≤ c1 ≤ cn ≤ 0x7E 0x00 ≤ x ≤ 0x12 (font 18 x 24) 0x00 ≤ x ≤ 0x0E (font 14 x 24) 0x00 ≤ x ≤ 0x0A (font 10 x 24) 0x00 ≤ x ≤ 0x08 (font 8 x 24) 0x00 ≤ d0...dk ≤ 0xFF k = cn – c1 + 1						
[Description]	Defines user programmable characters. y specifies the number of bytes in the vertical direction. c1 specifies the start character code and cn specifies the final character code of the characters map area. x specifies the width of the character to be replaced. d0...dk specifies the new character definition.						
[Notes]	<ul style="list-style-type: none"> • It is possible to define multiple characters for consecutive character codes. If only one character is desired, use c1 = cn. • if cn < c1, the command is not executed. • d is the dot data for the characters. The dot pattern is in the horizontal direction starting from the left. Any remaining dots on the right remain blank. • The data to define a user-defined character is (x × y) bytes. • To print a dot, set the corresponding bit to 1; to not have it print, set to 0. • This command can define different user-defined character patterns for each font. To select the font, use 0x1B 0x21. • The user programmable character definitions are cleared when commands 0x1B 0x40, 0x1D 0x2A or 0x1B 0x3F are executed or the device is reset or turned off. • x1 [d0 ... dk] will be repeated for each character to be replaced. 						
[Default]	Internal character set						
[Reference]	0x1B 0x25 , 0x1B 0x3F						
[Example]	To replace only the “A” character of the 11 cpi font table (font 18x24), the command sequence is: 0x1B 0x26 0x03 0x41 0x41 0x10 [48 bytes of the new character definition]. To replace “A” and “B” characters of the 11 cpi font table (font 18x24), the command sequence is: 0x1B 0x26 0x03 0x41 0x42 0x10 [48 bytes of the new character definition] 0x10 [48 bytes of the new character definition].						

0x1B 0x2D

<ESC ->

Turn underline mode on or off

Valid for
 TG1260HIII
 TG2460HIII, TG2460HIII EJC
 TG2480HIII
 TL60III
 TL80III

[Format] Hex 1B 2D n
 ASCII ESC - n

[Range] 0x00 ≤ n ≤ 0x02
 0x30 ≤ n ≤ 0x32

[Description] Turns underline mode on or off based on the value of n as follows:

n	FUNCTION
0x00, 0x30	Turns off underline mode
0x01, 0x31	Turns on underline mode (1 dot thick)
0x02, 0x32	Turns on underline mode (2 dot thick)

- [Notes]
- The device can underline all characters, but cannot underline the space and right-side character spacing set by command [0x09](#).
 - The device cannot underline 90°/270° rotated characters and white/black inverted characters.
 - When underline mode is turned off by setting the value of n to 0x00 or 0x30, the data which follows is not underlined.
 - Underline mode can also be turned on or off by using [0x1B 0x21](#). However, the last-received setting command is the effective one.

[Default] n = 0x00

[Reference] [0x1B 0x21](#)

[Example]



0x1B 0x34

<ESC 4>

Turn italic mode on or off

Valid for
 TG1260HIII
 TG2460HIII, TG2460HIII EJC
 TG2480HIII
 TL60III
 TL80III

[Format] Hex 1B 34 n
 ASCII ESC 4 n

[Range] 0x00 ≤ n ≤ 0x01
 0x30 ≤ n ≤ 0x31

[Description] Turns italic mode on or off based on the value of n as follows:

n	FUNCTON
0x00, 0x30	Turns off italic mode
0x01, 0x31	Turns on italic mode

- [Notes]
- The device can print any character in italic mode.
 - When italic mode is turned off by setting the value of n to 0x00 or 0x30, the data which follows is printed in normal mode.
 - Italic mode can also be turned on or off using [0x1B 0x21](#). However, the last-received setting command is the effective one.

[Default] n = 0x00

[Reference] [0x1B 0x21](#)

[Example]

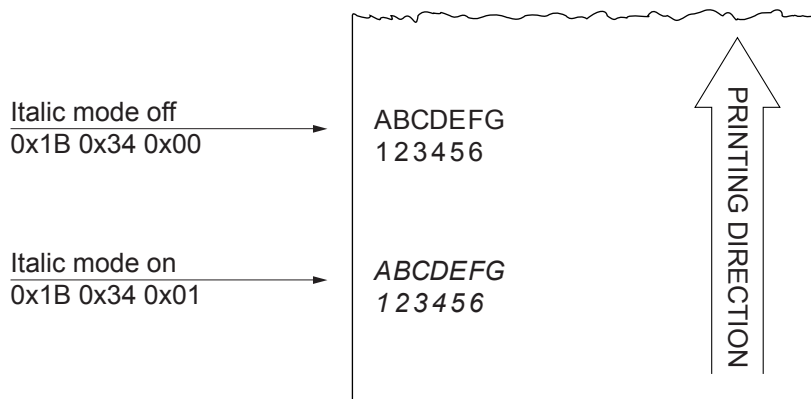



0x1B 0x3F

<ESC ?>

Cancel user-defined characters

Valid for
TG1260HIII
TG2460HIII, TG2460HIII EJC
TG2480HIII
TL60III
TL80III

[Format] Hex 1B 3F n
 ASCII ESC ? n

[Range] 0x20 ≤ n ≤ 0x7E

[Description] Cancels user-defined characters.

[Notes]

- This command cancels the pattern defined for the character code specified by n.
- This command deletes the pattern defined for the specified character code in the font selected by [0x1B 0x21](#).
- If the user-defined character has not been defined for the specified character code, the device ignores this command.

[Default]

[Reference] [0x1B 0x26](#), [0x1B 0x25](#)

[Example]

0x1B 0x45

<ESC E>

Turn bold mode on or off

Valid for
 TG1260HIII
 TG2460HIII, TG2460HIII EJC
 TG2480HIII
 TL60III
 TL80III

[Format] Hex 1B 45 n
 ASCII ESC E n

[Range] 0x00 ≤ n ≤ 0xFF

[Description] Turns bold mode on or off, based on the n value:
 - when the Least Significant Bit (LSB) of n is 0, the bold mode is off.
 - when the Least Significant Bit (LSB) of n is 1, the bold mode is on.

[Notes] • Only the Least Significant Bit (LSB) of n is effective.
 • [0x1B 0x21](#) also turns on and off the bold mode. However, the last received command is the effective one.

[Default] n = 0x00

[Reference] [0x1B 0x21](#)

[Example]

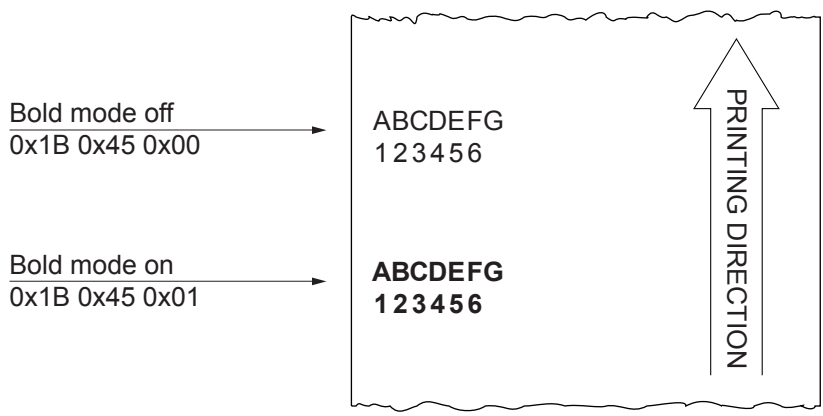

0x1B 0x47

<ESC G>

Turn double-strike mode on or off

Valid for
 TG1260HIII
 TG2460HIII, TG2460HIII EJC
 TG2480HIII
 TL60III
 TL80III

[Format] Hex 1B 47 n
 ASCII ESC G n

[Range] 0x00 ≤ n ≤ 0xFF

[Description] Turns double-strike mode on or off, based on the n value:
 - when the Least Significant Bit (LSB) of n is 0, the double-strike mode is off.
 - when the Least Significant Bit (LSB) of n is 1, the double-strike mode is on.

[Notes] • Only the Least Significant Bit (LSB) of n is effective.
 • Device output is the same in double-strike and bold mode.

[Default] n = 0x00

[Reference] [0x1B 0x21](#), [0x1B 0x45](#)

[Example]

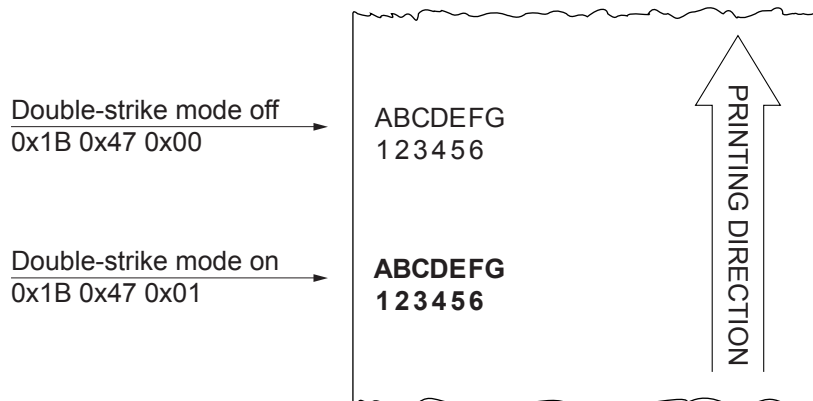



0x1B 0x4D

<ESC M>

Select character font

Valid for TG1260HIII
 TG2460HIII, TG2460HIII EJC
 TG2480HIII
 TL60III
 TL80III

[Format] Hex 1B 4D n
 ASCII ESC M n

[Range] n = 0x00, 0x01, 0x30, 0x31

[Description] Selects characters font depending of cpi value set (Char/Inch) as follows

CHAR/INCH	n	FUNCTION
A = 11 cpi	0x00, 0x30	Font 11 cpi (18x24)
B = 15 cpi	0x01, 0x31	Font 15 cpi (14x24)
A = 15 cpi	0x00, 0x30	Font 15 cpi (14x24)
B = 20 cpi	0x01, 0x31	Font 20 cpi (10x24)
A = 20 cpi	0x00, 0x30	Font 20 cpi (10x24)
B = 25 cpi	0x01, 0x31	Font 25 cpi (8x24)

[Notes]

[Default]

[Reference] 0x1B 0xC1

[Example]



0x1B 0x52

<ESC R>

Select an international character set

Valid for TG1260HIII
 TG2460HIII, TG2460HIII EJC
 TG2480HIII
 TL60III
 TL80III

[Format] Hex 1B 52 n
 ASCII ESC R n

[Range] 0x00 ≤ n ≤ 0x0A

[Description] Selects the international character set n according to the table below:

n	HEX	23	24	40	5B	5C	5D	5E	60	7B	7C	7D	7E
n	CHARACTER SET												
0x00	U.S.A.	#	\$	@	[\]	^	`	{		}	~
0x01	France	#	\$	à	°	ç	§	^	`	é	ù	è	“
0x02	Germany	#	\$	§	Ä	Ö	Ü	^	`	ä	ö	ü	ß
0x03	United Kingdom	£	\$	@	[\]	^	`	{		}	~
0x04	Denmark I	#	\$	@	Æ	Ø	Å	^	`	æ	ø	å	~
0x05	Sweden	#	¤	É	Ä	Ö	Å	Ü	é	ä	ö	å	ü
0x06	Italy	#	\$	@	°	\	é	^	ù	à	ò	è	ì
0x07	Spain I	Pt	\$	@	i	Ñ	¿	^	`	“	ñ	}	~
0x08	Japan	#	\$	@	[¥]	^	`	{		}	~
0x09	Norway	#	¤	É	Æ	Ø	Å	Ü	é	æ	ø	å	ü
0x0A	Denmark II	#	\$	É	Æ	Ø	Å	Ü	é	æ	ø	å	ü

[Notes]

[Default] n = 0x00

[Reference]

[Example]

0x1B 0x56

<ESC V>

Set 90° rotated print mode

Valid for
 TG1260HIII
 TG2460HIII, TG2460HIII EJC
 TG2480HIII
 TL60III
 TL80III

[Format] Hex 1B 56 n
 ASCII ESC V n

[Range] n = 0x00, 0x01, 0x30, 0x31

[Description] Turns 90° rotation mode on or off based on the value of n as follows:

n	FUNCTION
0x00, 0x30	Disable 90° rotation mode
0x01, 0x31	Enable 90° rotation mode

- [Notes]
- When underlined mode is turned on, the device does not underline 90° rotated characters. All the same it's possible select the underline mode.
 - Double-width and double-height commands in 90° rotation mode enlarge characters in the opposite directions from double-height and double-width commands in normal mode.

Default] n = 0x00

[Reference] [0x1B 0x21](#), [0x1B 0x2D](#)

[Example]

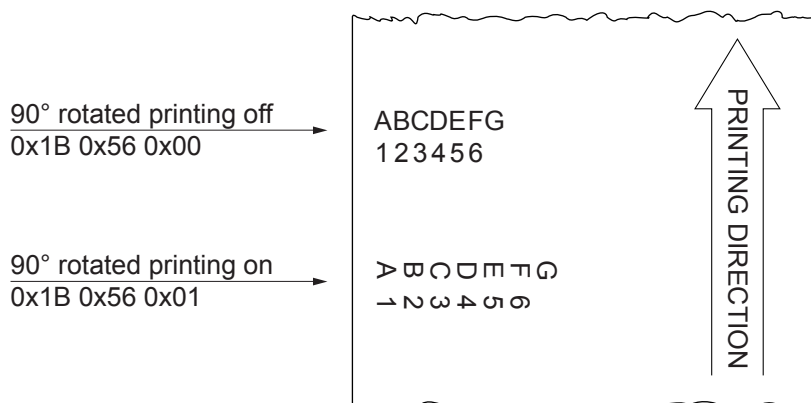



0x1B 0x74

<ESC t>

Select character code table

Valid for TG1260HIII
 TG2460HIII, TG2460HIII EJC
 TG2480HIII
 TL60III
 TL80III

[Format] Hex 1B 74 n
 ASCII ESC t n

[Range] $0x01 \leq n \leq 0x35, n = 0xFF$

[Description] Select a page n from the character code table as follows:

n	PAGE
0x00	PC437 - U.S.A., Standard Europe
0x01	Katakana
0x02	PC850 - Multilingual
0x03	PC860 - Portuguese
0x04	PC863 - Canadian/French
0x05	PC865 - Nordic
0x06	VISCII - Vietnamese Standard Code
0x0B	PC851 - Greek on request
0x0C	PC853 - Turkish on request
0x0D	PC857 - Turkish
0x0E	PC737 - Greek
0x0F	ISO8859-7 - Greek on request
0x10	WPC1252 - Scandinavian
0x11	PC866 - Cyrillic 2
0x12	PC852 - Latin 2
0x13	PC858 for Euro symbol in position 0xD5
0x14	KU42 - Thai
0x15	TIS11 - Thai on request
0x1A	TIS18 - Thai on request
0x1E	TCVN_3 - Vietnamese on request
0x1F	TCVN_3 - Vietnamese on request
0x20	PC720 - Arabic on request
0x21	WPC775 - Baltic Rim on request
0x22	PC855 - Cyrillic



n	PAGE
0x23	PC861 - Icelandic on request
0x24	PC862 - Hebrew
0x25	PC864 - Arabic
0x26	PC869 - Greek on request
0x27	ISO8859-2 - Latin 2 on request
0x28	ISO8859-15 - Latin 9 on request
0x29	PC1098 - Farsi
0x2A	PC1118 - Lithuanian on request
0x2B	PC1119 - Lithuanian on request
0x2C	PC1125 - Ukrainian
0x2D	WPC1250 - Latin 2
0x2E	WPC1251 - Cyrillic
0x2F	WPC1253 - Greek
0x30	WPC1254 - Turkish
0x31	WPC1255 - Hebrew
0x32	WPC1256 - Arabic
0x33	WPC1257 - Baltic Rim
0x34	WPC1258 - Vietnamese
0x35	KZ1048 - Kazakh on request
0xFF	Space page

- [Notes]
- PC866 and PC852 tables are valid only for TrueType fonts.
 - The tables are selectable only if the code pages are present on the machine. By selecting a code page not present on the machine, the code page remains the one currently in use.
 - Make sure to select the font type “International” with the command **0x1C 0x25** or with the “Font type” parameter during the setup procedure (refer to the user manual of the device).

[Default] n = 0x00

[Reference] **0x1C 0x25**

[Example] For printing Euro symbol (€), the command sequence is:
0x1B, 0x74, 0x13, 0xD5

0x1B 0x7B

<ESC {>

Turn upside-down printing mode on or off

Valid for
 TG1260HIII
 TG2460HIII, TG2460HIII EJC
 TG2480HIII
 TL60III
 TL80III

[Format] Hex 1B 7B n
 ASCII ESC { n

[Range] 0x00 ≤ n ≤ 0xFF

[Description] Turns upside-down printing mode on or off, based on the value of n:
 - when the Least Significant Bit (LSB) of n is 0, the upside-down printing mode is off.
 - when the Least Significant Bit (LSB) of n is 1, the upside-down printing mode is on.

[Notes] • Only the Least Significant Bit (LSB) of n is effective.
 • This command is valid only if entered at the beginning of a line.
 • In upside-down printing mode, the device rotates the line to be printed 180° and then prints it.

[Default] n = 0x00

[Reference]

[Example]

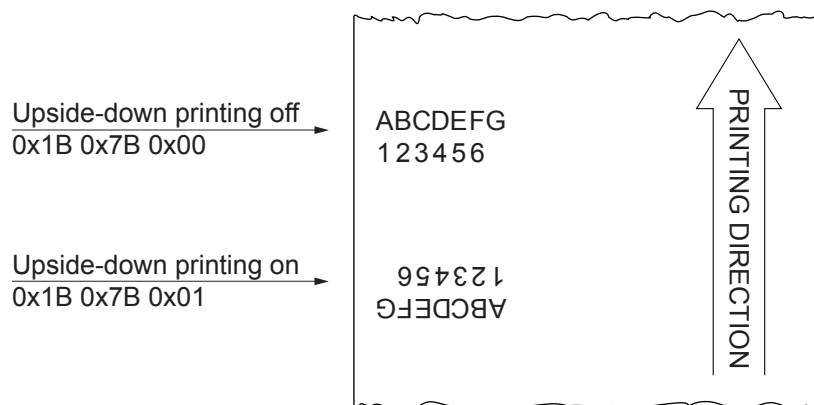

0x1B 0xC1

Select character pitch

Valid for	TG1260HIII TG2460HIII, TG2460HIII EJC TG2480HIII TL60III TL80III
-----------	--

[Format]	Hex 1B C1 n ASCII ESC 0xC1 n
----------	---

[Range]	0x00 ≤ n ≤ 0x02 0x30 ≤ n ≤ 0x32
---------	------------------------------------

[Description] This command selects the character pitch expressed in cpi (characters per inch) based on the values of n as follows:

n	PITCH	
0x00, 0x30	Font A = 11 cpi	Font B = 15 cpi
0x01, 0x31	Font A = 15 cpi	Font B = 20 cpi
0x02, 0x32	Font A = 20 cpi	Font B = 25 cpi

[Notes]

[Default] n = 0x00

[Reference] [0x1B 0x21](#)

[Example]

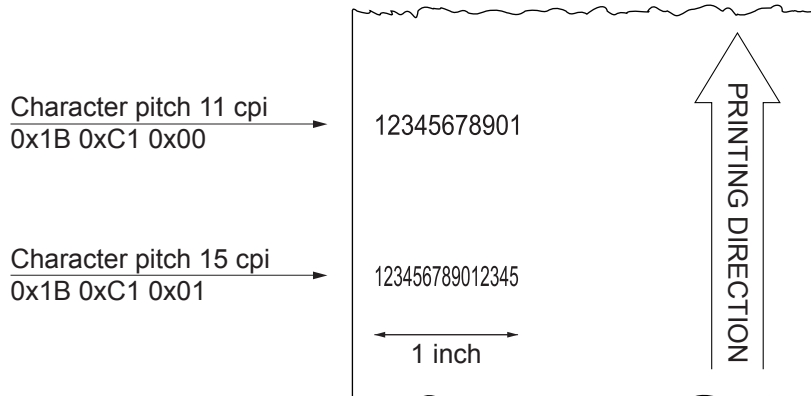



0x1C 0x25

<FS %>

Select the font type

Valid for TG1260HIII
 TG2460HIII, TG2460HIII EJC
 TG2480HIII
 TL60III
 TL80III

[Format] Hex 1C 25 n
 ASCII FS % n

[Range] n = 0x00, 0x01

[Description] Select the font type based on the value of n as follows:

n	FONT TYPE
0x00	International
0x01	Chinese GB18030
0x02	Korean CP949

[Notes]

- The selection made by this command is stored in the RAM memory. Turning off the device reverts to the default value, that can be set with the “Font type” parameter during the setup procedure (refer to the user manual of the device).
- After selecting the font type “International” it must be selected the desired character code table using the command [0x1B 0x74](#).

[Default] n = 0x00

[Reference] [0x1B 0x74](#), see the Chinese fonts management commands manual.

[Example]



0x1D 0x21

<GS !>

Select character size

Valid for	TG1260HIII TG2460HIII, TG2460HIII EJC TG2480HIII TL60III TL80III
-----------	--

[Format]	Hex 1D 21 n ASCII GS ! n
----------	--

[Range]	0x00 ≤ n ≤ 0x07 0x10 ≤ n ≤ 0x17 0x20 ≤ n ≤ 0x27 0x30 ≤ n ≤ 0x37 0x40 ≤ n ≤ 0x47 0x50 ≤ n ≤ 0x57 0x60 ≤ n ≤ 0x67 0x70 ≤ n ≤ 0x77
---------	--

[Description] Selects character height and width, as follows:

- Bits 0 to 3: to select character height (see table 2).
- Bits 4 to 7: to select character width (see table 1).

Table 1 Select character width		Table 2 Select character height	
HEX	WIDTH	HEX	HEIGHT
00	1 (normal)	00	1 (normal)
10	2 (width = 2x)	01	2 (height = 2x)
20	3 (width = 3x)	02	3 (height = 3x)
30	4 (width = 4x)	03	4 (height = 4x)
40	5 (width = 5x)	04	5 (height = 5x)
50	6 (width = 6x)	05	6 (height = 6x)
60	7 (width = 7x)	06	7 (height = 7x)
70	8 (width = 8x)	07	8 (height = 8x)

[Notes]

- This command is effective for all characters (except HRI characters).
- If n falls outside the defined range, this command is ignored.
- Characters enlarged to different heights on the same line are aligned at the baseline or top line.
- **0x1B 0x21** can also be used to select character size. However, the setting of the last received command is the effective one.
- This command is effective on the x and y axes. In case of 90°/270° rotated characters, bit from 0 to 3 select character width and bit from 4 to 7 select character height.

[Default] n = 0x00

[Reference] [0x1B 0x21](#)

[Example] For printing a character with 6x width and height the command sequence is:
0x1D 0x21 0x55

0x1D 0x42

<GS B>

Turn black and white reverse printing mode on or off

Valid for
 TG1260HIII
 TG2460HIII, TG2460HIII EJC
 TG2480HIII
 TL60III
 TL80III

[Format] Hex 1D 42 n
 ASCII GS B n

[Range] 0x00 ≤ n ≤ 0xFF

[Description] Turns black and white reverse printing mode on or off, based on the value of n:
 - when the Least Significant Bit (LSB) of n is 0, white/black reverse printing is turned off.
 - when the Least Significant Bit (LSB) of n is 1, white/black reverse printing is turned on.

[Notes]

- Only the Least Significant Bit (LSB) of n is effective.
- This command is available for both built-in and user-defined characters.
- This command does not affect bit image, downloaded bit image, barcode, HRI characters and spacing skipped by 0x09, 0x1B 0x24 and 0x1B 0x5C.
- This command does not affect white space between lines.
- White/black reverse mode has a higher priority than underline mode. Even if underline mode is on, it will be disabled (but not cancelled) when black and white reverse mode is selected.

[Default] n = 0x00

[Reference]

[Example]

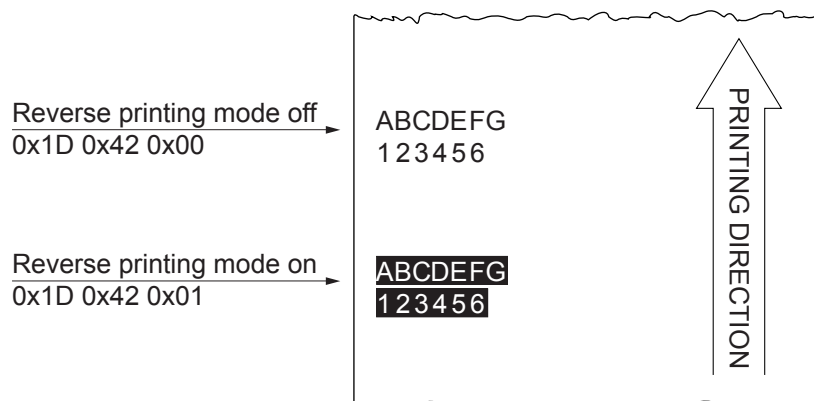

LINE SPACING COMMANDS

0x1B 0x30

<ESC 0>

Select 1/8-inch line spacing

Valid for TG1260HIII
 TG2460HIII, TG2460HIII EJC
 TG2480HIII
 TL60III
 TL80III

[Format] Hex 1B 30
 ASCII ESC 0

[Range]

[Description] Selects 1/8-inch line spacing.

[Notes]

[Default]

[Reference] [0x1B 0x32](#), [0x1B 0x33](#)

[Example]





0x1B 0x32

<ESC 2>

Select 1/6-inch line spacing

Valid for

- TG1260HIII
- TG2460HIII, TG2460HIII EJC
- TG2480HIII
- TL60III
- TL80III

[Format]

Hex	1B	32
ASCII	ESC	2

[Range]

[Description] Selects 1/6-inch line spacing.

[Notes]

[Default]

[Reference] [0x1B 0x30](#), [0x1B 0x33](#)

[Example]

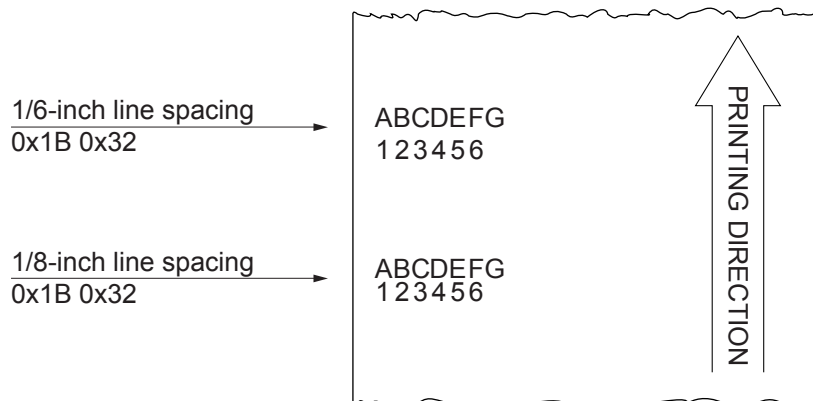



0x1B 0x33

<ESC 3>

Set line spacing

Valid for	TG1260HIII TG2460HIII, TG2460HIII EJC TG2480HIII TL60III TL80III
[Format]	Hex 1B 33 n ASCII ESC 3 n
[Range]	0x00 ≤ n ≤ 0xFF
[Description]	Sets line spacing to [n × (vertical or horizontal motion unit)].
[Notes]	<ul style="list-style-type: none">• The horizontal and vertical motion unit are specified by 0x1D 0x50. Changing the horizontal or vertical motion unit does not affect the current line spacing.• The 0x1D 0x50 command can change the horizontal (and vertical) motion unit. However, the value cannot be less than the minimum vertical movement amount.• In standard mode, the vertical motion unit is used.• The maximum spacing is 32.5 mm.
[Default]	n = 0x40 (1/6 inch)
[Reference]	0x1B 0x30 , 0x1B 0x32 , 0x1D 0x50
[Example]	

PRINT COMMANDS

0x0A

<LF>

Print and line feed

Valid for	TG1260HIII
	TG2460HIII, TG2460HIII EJC
	TG2480HIII
	TL60III
	TL80III

[Format]	Hex	0A
	ASCII	LF

[Range]

[Description] This command sets the print position to the beginning of the line printing the data in the buffer and feeding one line based on the line spacing set with the command [0x1B 0x30](#) or [0x1B 0x32](#).

[Notes] If the buffer is empty, the printing feeds of a value equal to the sum of the character height and line spacing.

[Default] 1/6-inch (32 dots)

[Reference] [0x1B 0x30](#), [0x1B 0x32](#), [0x1B 0x33](#), [0x0D](#)

[Example]

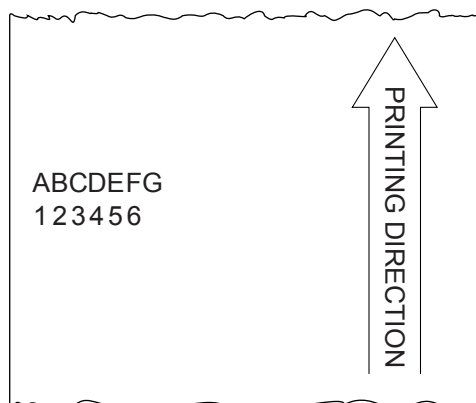

To print the ticket shown in figure the command sequence is:
 ABCDEFG 0x0A 123456 0x0A

0x0D

<CR>

Print and carriage return

Valid for	TG1260HIII TG2460HIII, TG2460HIII EJC TG2480HIII TL60III TL80III
-----------	--

[Format]	Hex 0D ASCII CR
----------	--

[Range]

[Description] This command handles the end of a line text.

[Notes] If “Autofeed” setup parameter is set to “CR enabled”, this command works in the same way as 0x0A, otherwise it is disregarded.

[Default] See “Autofeed” setup parameter (refer to the user manual of the device).

[Reference] [0x0A](#)

[Example]

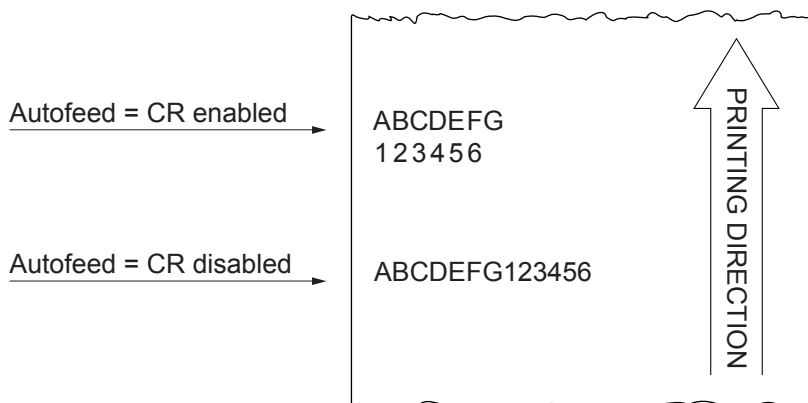

To print the ticket shown in figure the command sequence is:
ABCDEFGH 0x0D 123456 0x0D



0x1B 0x4A

<ESC J>

Print and paper feed

Valid for	TG1260HIII TG2460HIII, TG2460HIII EJC TG2480HIII TL60III TL80III
-----------	--

[Format]	Hex 1B 4A n ASCII ESC J n
[Range]	0x00 ≤ n ≤ 0xFF
[Description]	Prints the data saved in the print buffer and feeds the paper [n × vertical or horizontal motion unit].
[Notes]	<ul style="list-style-type: none">• After printing has been completed, this command sets the print starting position to the beginning of the line.• The paper feed amount set by this command does not affect the values set by 0x1B 0x30 or 0x1B 0x32.• The horizontal and vertical motion units are specified by 0x1D 0x50.• 0x1D 0x50 can change the vertical (and horizontal) motion unit. However, the value cannot be less than the minimum vertical movement amount.• In standard mode, the vertical motion unit is used.
[Default]	
[Reference]	0x1D 0x50
[Example]	



0x1B 0x64

<ESC d>

Print and feed paper n lines

Valid for	TG1260HIII TG2460HIII, TG2460HIII EJC TG2480HIII TL60III TL80III
-----------	--

[Format]	Hex 1B 64 n ASCII ESC d n
[Range]	0x00 ≤ n ≤ 0xFF
[Description]	Prints the data saved in the print buffer and feeds the paper n lines.
[Notes]	<ul style="list-style-type: none">• n rows paper feed is equivalent to (n × char height + line spacing set).• Sets the print starting position at the beginning of the line.• This command does not affect the line spacing set by 0x1B 0x32 or 0x1B 0x33.• The maximum paper feed amount is 254 lines. Even if a paper feed amount of more than 254 lines is set, the device feeds the paper only 254 lines.
[Default]	
[Reference]	0x1B 0x32 , 0x1B 0x33
[Example]	



0x1C 0x82

Print date

Valid for	TG1260HIII
	TG2460HIII, TG2460HIII EJC
	TG2480HIII
	TL60III
	TL80III

[Format]	Hex	1C	82
	ASCII	FS	0x82

[Range]

[Description] Prints date in the format specified by the command [0x1C 0x84](#) with the parameter n = 0x44.

[Notes]

- The clock works only with the device switched on. If the device is turned off, the clock stops.
- It is necessary to initialize date and time to every device init.

[Default] "dd/mm/yy"

[Reference] [0x1C 0x83](#), [0x1C 0x84](#)

[Example]



0x1C 0x83

Print time

Valid for	TG1260HIII TG2460HIII, TG2460HIII EJC TG2480HIII TL60III TL80III
-----------	--

[Format]	Hex 1C 83 ASCII FS 0x83
[Range]	
[Description]	Prints time in the format specified by the command 0x1C 0x84 with the parameter n = 0x54.
[Notes]	<ul style="list-style-type: none">• The clock works only with the device switched on. If the device is turned off, the clock stops.• It is necessary to initialize date and time to every device init.
[Default]	“hh:mm:ss”
[Reference]	0x1C 0x82 , 0x1C 0x84
[Example]	



0x1D 0x7C

<GS |>

Set printing density

Valid for TG1260HIII
 TG2460HIII, TG2460HIII EJC
 TG2480HIII
 TL60III
 TL80III

[Format] Hex 1D 7C n
 ASCII GS | n

[Range] $0x02 \leq n \leq 0x06$
 $0x32 \leq n \leq 0x36$

[Description] Sets printing density. n specifies printing density as follows:

n	PRINTING DENSITY
0x02, 0x32	- 25%
0x03, 0x33	- 12.5%
0x04, 0x34	0%
0x05, 0x35	+ 12.5%
0x06, 0x36	+ 25%

[Notes] Printing density reverts to the default value when the device is reset or turned off.

[Default] n = 0x04

[Reference]

[Example]

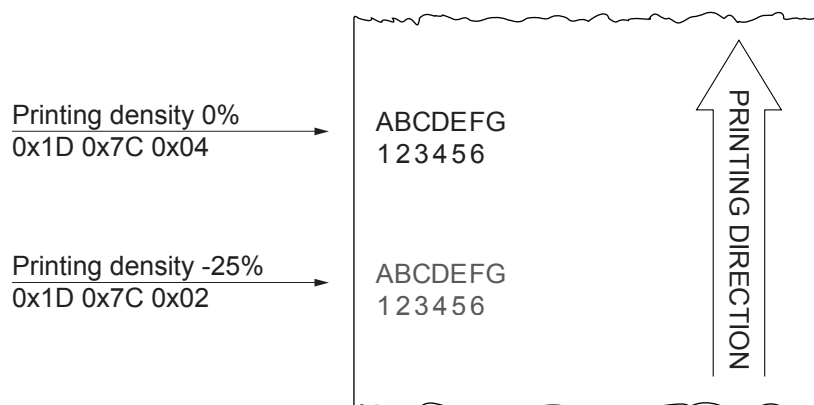



STATUS COMMANDS

0x10 0x04

<DLE EOT>

Real-time status transmission

Valid for	TG1260HIII TG2460HIII, TG2460HIII EJC TG2480HIII TL60III TL80III
-----------	--

[Format]	Hex 10 04 n ASCII DLE EOT n
----------	---

[Range]	0x01 ≤ n ≤ 0x04 n = 0x11, 0x14, 0x15
---------	---

[Description] Transmits the selected status when this command is received. The status to be transmitted is indicated in the following table:

n = 0x01	transmits device status
n = 0x02	transmits off-line status
n = 0x03	transmits error status
n = 0x04	transmits paper roll sensor status
n = 0x11	transmits print status
n = 0x14	transmits full status
n = 0x15	transmits device ID

Device status (n = 0x01)

BIT	OFF/ON	HEX	FUNCTION
0	Off	00	Not used. Fixed to off
1	On	02	Not used. Fixed to on
2	-	-	RESERVED
3	Off	00	On-line
	On	08	Off-line
4	On	10	Not used. Fixed to on
5	-	-	RESERVED
6	-	-	RESERVED
7	Off	00	LF key released
	On	80	LF key pressed



Off-line status (n = 0x02)

BIT	OFF/ON	HEX	FUNCTION
0	Off	00	Not used. Fixed to off
1	On	02	Not used. Fixed to on
2	Off	00	Cover closed
	On	04	Cover opened
3	Off	00	Paper isn't fed by FEED key
	On	08	Paper is fed by FEED key
4	On	10	Not used. Fixed to on
5	Off	00	Paper present
	On	20	Printing stop due to paper end
6	Off	00	No error
	On	40	Error
7	Off	00	Not used. Fixed to off

Error status (n = 0x03)

BIT	OFF/ON	HEX	FUNCTION
0	Off	00	Not used. Fixed to off
1	On	02	Not used. Fixed to on
2	-	-	RESERVED
3	Off	00	Autocutter ok
	On	08	Autocutter error
4	On	10	Not used. Fixed to on
5	Off	00	No unrecoverable error
	On	20	Unrecoverable error
6	Off	00	No auto-recoverable error
	On	40	Auto-recoverable error
7	Off	00	Not used. Fixed to off



Paper roll sensor status (n = 0x04)

BIT	OFF/ON	HEX	FUNCTION
0	Off	00	Not used. Fixed to off
1	On	02	Not used. Fixed to on
2, 3	Off	00	Paper present
	On	0C	Low paper
4	On	10	Not used. Fixed to on
5, 6	Off	00	Paper present
	On	60	Paper not present
7	Off	00	Not used. Fixed to off

Print status (n = 0x11)

BIT	OFF/ON	HEX	FUNCTION
0	Off	00	Not used. Fixed to off
1	On	02	Not used. Fixed to on
2	Off	00	Paper drag motor off
	On	04	Paper drag motor on
3	-	-	RESERVED
4	On	10	Not used. Fixed to on
5	Off	00	Paper present
	On	20	Printing stopped out for paper end
6	-	-	RESERVED
7	Off	00	Not used. Fixed to off

Full status (n = 0x14, 6 bytes)

1st byte = 0x10 (DLE)

2nd byte = 0x0F



3rd byte = Paper status

BIT	OFF/ON	HEX	FUNCTION
0	Off	00	Paper present
	On	01	Paper not present
1	-	-	RESERVED
2	Off	00	Paper present
	On	04	Low paper
3	-	-	RESERVED
4	-	-	RESERVED
5	Off	00	Ticket not present in output
	On	20	Ticket present in output
6	Off	00	Paper virtually present *
	On	40	Virtual paper end *
7	Off	00	Black mark is placed over the sensor
	On	80	Black mark is not placed over the sensor

(*) Paper virtually present is set when the paper length available, read by `0x1D 0xE1`, is 0.

4th byte = User status

BIT	OFF/ON	HEX	FUNCTION
0	Off	00	No error, printing head down
	On	01	Printing head up error
1	Off	00	Cover closed
	On	02	Cover opened
2	Off	00	No spooling
	On	04	Spooling
3	Off	00	Drag paper motor off
	On	08	Drag paper motor on
4	-	-	RESERVED
5	Off	00	LF key released
	On	20	LF key pressed
6	Off	00	FF key released
	On	40	FF key pressed
7	-	-	RESERVED



5th byte = Recoverable status error

BIT	OFF/ON	HEX	FUNCTION
0	Off	00	Head temperature ok
	On	01	Head temperature error
1	Off	00	No COM error
	On	02	RS232 COM error
2	-	-	RESERVED
3	Off	00	Power supply voltage ok
	On	08	Power supply voltage error
4	-	-	RESERVED
5	Off	00	Acknowledge command
	On	20	Not acknowledge command error
6	Off	00	Free paper path
	On	40	Paper jam
7	Off	00	Black mark search ok
	On	80	Error in black mark search

6th byte = Unrecoverable error status

BIT	OFF/ON	HEX	FUNCTION
0	Off	00	Autocutter ok
	On	01	Autocutter error
1	Off	00	Autocutter cover ok
	On	02	Autocutter cover open
2	Off	00	RAM ok
	On	04	RAM error
3	Off	00	EEPROM ok
	On	08	EEPROM error
4	-	-	RESERVED
5	-	-	RESERVED
6	-	-	RESERVED
7	-	-	RESERVED



Transmit device ID (n = 0x15)

1st byte = (refer to command [0x1D 0x49](#))

[Notes] This command is immediately executed even when the data buffer is full.

[Default]

[Reference]

[Example] Request for device status transmission:

0x10 0x04 0x01

Device response:

0x80 LF key pressed



0x1C 0xEA

Transmit the device serial number

Valid for	TG1260HIII TG2460HIII, TG2460HIII EJC TG2480HIII TL60III TL80III
-----------	--

[Format]	Hex 1C EA n ASCII FS 0xEA n
----------	---

[Range] n = 0x52, 0x72

[Description] Transmits the device serial number.

- [Notes]
- The serial number is a string of 16 alphanumeric characters.
 - If the printer serial number is not defined, the device returns a string of 16 characters with a value of 0x00.

[Default]

[Reference]

[Example] To read the device serial number the command sequence is:
0x1C 0xEA 0x52

The device returns a string of 16 alphanumeric characters just like the following:
'ABC0123456789012'



0x1D 0xE0

Enable or disable automatic FULL STATUS BACK

Valid for TG1260HIII
TG2460HIII, TG2460HIII EJC
TG2480HIII
TL60III
TL80III

[Format] Hex 1D E0 n
ASCII GS 0xE0 n

[Range] 0x00 ≤ n ≤ 0xFF

[Description] Enable or disable automatic full status back. n specifies the composition of full status as follows:

BIT	OFF/ON	HEX	FUNCTION
0	Off	00	Disable paper status
	On	01	Enable paper status
1	Off	00	Disable user status
	On	02	Enable user status
2	Off	00	Disable recoverable error status
	On	04	Enable recoverable error status
3	Off	00	Disable unrecoverable error status
	On	08	Enable unrecoverable error status
4	-	-	Undefined
5	-	-	Undefined
6	-	-	Undefined
7	-	-	Undefined

[Notes] Once enable at least one byte of the full status, for each change of at least one of the bits which compose the required status, the status sent in automatic from the device will be so composed as follows:

1st Byte = 0x10 (DLE=

2nd Byte = n

[Default]

[Reference] [0x10 0x04](#)

[Example]



0x1D 0xE1

Reading of length paper available before virtual paper-end

Valid for	TG1260HIII TG2460HIII, TG2460HIII EJC TG2480HIII TL60III TL80III
-----------	--

[Format]	Hex 1D E1 ASCII GS 0xE1
[Range]	
[Description]	Reading of length paper available before virtual paper-end (expressed in centimetres). The command return a string pointing out how much paper is available.
[Notes]	<ul style="list-style-type: none">• The length of residual paper reported is just as an indication because tolerances and other factors are not taken into consideration (paper thickness, roll core diameter, roll core thickness).• The virtual paper-end limit is set by the command 0x1D 0xE6.• To set virtual paper-end limit, measure the length of the paper from low paper to the end of the roll, using several of them.
[Default]	
[Reference]	0x1D 0xE6
[Example]	If there are 5.1 m before paper end, the answer will be: '510cm'



0x1D 0xE2

Reading number of cuts performed by the autocutter

Valid for

- TG1260HIII
- TG2460HIII, TG2460HIII EJC
- TG2480HIII
- TL60III
- TL80III

[Format]

Hex	1D	E2
ASCII	GS	0xE2

[Range]

[Description] Reading the number of cuts performed by the autocutter.

[Notes] The command returns a string indicating how many cuts are performed by the autocutter.

[Default]

[Reference]

[Example] If the autocutter has performed 785 cuts, the answer will be:
'785cuts'



0x1D 0xE3

Reading of length of printed paper

Valid for	TG1260HIII
	TG2460HIII, TG2460HIII EJC
	TG2480HIII
	TL60III
	TL80III

[Format]	Hex	1D	E3
	ASCII	GS	0xE3

[Range]

[Description] Reading of length expressed in centimetre of printed paper.

[Notes] The command returns a string indicating how much paper is printed.

[Default]

[Reference]

[Example] If the device has printed about 388.9 m, the answer will be:
'38890cm'



0x1D 0xE5

Reading number of power up

Valid for

- TG1260HIII
- TG2460HIII, TG2460HIII EJC
- TG2480HIII
- TL60III
- TL80III

[Format]

Hex	1D	E5
ASCII	GS	0xE5

[Range]

[Description] Reading number of power up of the device.

[Notes] The command returns a string indicating the number of device power ups.

[Default]

[Reference]

[Example] If the device is turned on 512 times, the answer will be:
'512on'



BIT-IMAGE COMMANDS

0x1B 0x2A

<ESC *>

Select bit image mode

Valid for	TG1260HIII TG2460HIII, TG2460HIII EJC TG2480HIII TL60III TL80III
-----------	--

[Format]	Hex 1B 2A m nL nH d1...dk
	ASCII ESC * m nL nH d1...dk

[Range]	m = 0x00, 0x01, 0x20, 0x21 0x00 ≤ nL ≤ 0xFF 0x00 ≤ nH ≤ 0x03 0x00 ≤ d ≤ 0xFF
---------	---

[Description] Selects a bit image mode using m for the number of dots specified by nL and nH, as follows:

m	MODE	VERTICAL DIRECTION		HORIZONTAL DIRECTION	
		N. DOTS	DPI	DPI	N. DATA (k)
0x00	8 dots single density	8	67	100	nL + nH × 256
0x01	8 dots double density	8	67	200	nL + nH × 256
0x20	24 dots single density	24	200	100	(nL + nH × 256) × 3
0x21	24 dots double density	24	200	200	(nL + nH × 256) × 3

- [Notes]
- The nL and nH commands indicate the number of dots of the bit image in the horizontal direction. The number of dots is calculated using: nL + nH × 256.
 - If the bit image data input exceeds the number of dots to be printed on a line, the excess data is ignored.
 - d indicates the bit image data. Set a corresponding bit to 1 to print a dot, or to 0 to not print the dot.
 - If the value of m is outside the specified range, nL and data following it are processed as normal data.
 - If the width of the printing area set by 0x1D 0x4C and 0x1D 0x57 is less than the width required by the data set using 0x1B 0x2A, the excess data are ignored.
 - To print the bit image use 0x0A, 0x0D, 0x1B 0x4A or 0x1B 0x64.
 - After printing a bit image, the device returns to normal data processing mode.
 - This command is not affected by the bold, double-strike, underline (etc.) print modes, except for the upside-down mode.



- The relationship between the image data and the dots to be printed is as follows:

8-dot bit image

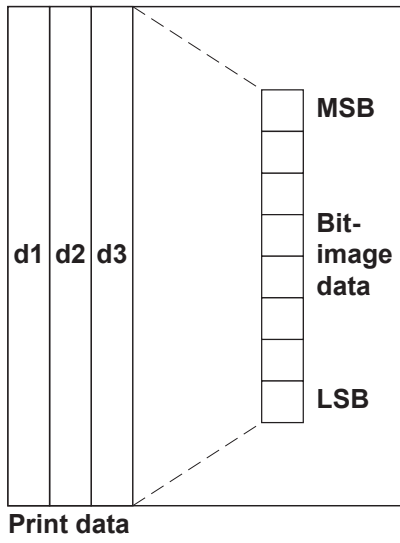

24-dot bit image

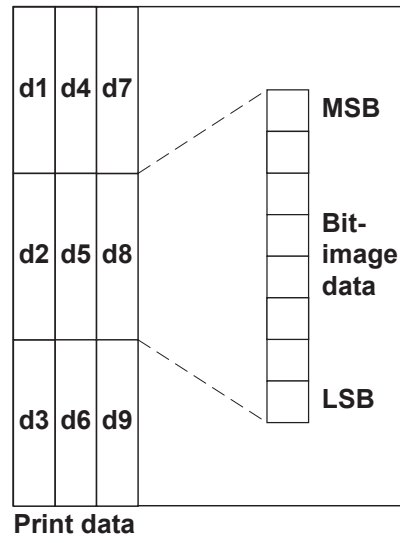

[Default]

[Reference]

[Example]

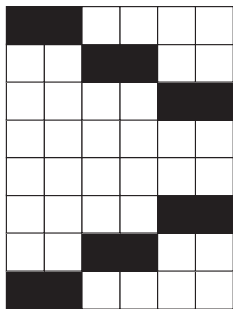

8 dots single density

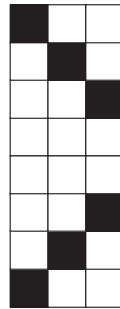

8 dots double density

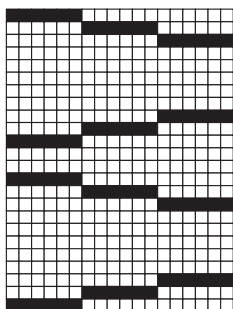

24 dots single density

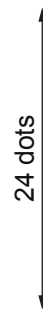
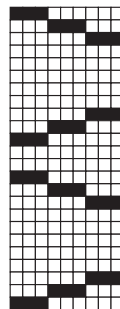

24 dots double density



0x1C 0x70

<FS p>

Print NV bit image

Valid for

TG1260HIII
 TG2460HIII, TG2460HIII EJC
 TG2480HIII
 TL60III
 TL80III

[Format]

Hex	1C	70	n	m
ASCII	FS	p	n	m

[Range]

0x01 ≤ n ≤ 0xFF
 0x00 ≤ m ≤ 0x03
 0x30 ≤ m ≤ 0x33

[Description]

Prints a NV bit image n using the mode specified by m:

m	MODE
0x00, 0x30	Normal
0x01, 0x31	Double width
0x02, 0x32	Double heighth
0x03, 0x33	Quadruple

- n is the number of the NV bit image

[Notes]

- NV bit image means a bit image which is defined in a non-volatile memory by [0x1C 0x71](#) and printed by [0x1C 0x70](#).
- This command is not effective when the specified NV bit image has not been defined.
- In standard mode, this command is effective only when there is no data in the print buffer.
- This command is not affected by print modes (bold, underline, character size, white/black reverse printing, etc.), except upside-down printing mode.
- If the printing area width set by [0x1D 0x4C](#) and [0x1D 0x57](#) for the NV bit image is less than one vertical line, the following processing is executed only on the line in question. However, in NV bit image mode, one vertical line means 1 dot (one half dot for slip paper) in normal mode (m = 0x00, 0x30) and in double-height mode (m = 0x02, 0x32), and it means 2 dots (two half dots for slip paper) in double-width mode (m = 0x01, 0x31) and in quadruple mode (m = 0x03, 0x33).
- The printing area width is extended to the right in NV bit image mode up to one line vertically. In this case, printing does not exceed the printable area.
- If the printing area width cannot be extended by one line vertically, the left margin is reduced to accommodate one line vertically.
- If the downloaded bit image to be printed exceeds one line, the excess data is not printed.
- This command feeds dots (for the height n of the NV bit image) in normal and double-width modes, and (for the height n x 2 of the VN bit image) in double-height and quadruple modes, regardless of the line spacing specified by [0x1B 0x32](#) or [0x1B 0x33](#).
- After printing the bit image, this command sets the print position to the beginning of the line and processes the data that follows as normal data.



[Default]

[Reference] 0x1C 0x71

[Example]



0x1C 0x71

<FS q>

Define NV bit image

Valid for	TG1260HIII TG2460HIII, TG2460HIII EJC TG2480HIII TL60III TL80III				
[Format]	Hex	1C	71	n	[xL xH yL yH d1...dk] 1...[xL xH yL yH d1...dk] n
	ASCII	FS	q	n	[xL xH yL yH d1...dk] 1...[xL xH yL yH d1...dk] n
[Range]	$0x01 \leq n \leq 0xFF$ $0x00 \leq xL \leq 0xFF$ $0x00 \leq xH \leq 0x03$ (when $1 \leq (xL + xH \times 256) \leq 1023$) $0x00 \leq yL \leq 0x01$ (when $1 \leq (yL + yH \times 256) \leq 288$) $0x00 \leq d \leq 0xFF$ $k = (xL + xH \times 256) \times (yL + yH \times 256) \times 8$ Total defined data area = 3 MB				
[Description]	Define the NV bit image specified by n. <ul style="list-style-type: none"> • n specifies the number of the defined NV bit image. • xL, xH specifies $(xL + xH \times 256) \times 8$ dots in the horizontal direction for the NV bit image you are defining. • yL, yH specifies $(yL + yH \times 256) \times 8$ dots in the vertical direction for the NV bit image you are defining. 				
[Notes]	<ul style="list-style-type: none"> • Frequent write command execution may cause damage the NV memory. Therefore, it is recommended to write the least possible in the memory and no more than 10 times per day. • This command cancels all NV bit images that have already been defined by this command. The device can not redefine only one of several data definitions previously defined. In this case, all data needs to be sent again. • NV bit image means a bit image which is defined in a non-volatile memory by 0x1C 0x71 and printed by 0x1C 0x70. • When the amount of data exceeds the capacity left in the range defined by xL, xH, yL, yH, the device processes xL, xH, yL, yH out of the defined range. • In the first group of NV bit images, when any of the parameters xL, xH, yL, yH is out of the definition range, this command is disabled. • In groups of NV bit images other than the first one, when the device processes xL, xH, yL, yH out of the defined range, it stops processing this command and starts writing into the non-volatile images. At this time, NV bit images that haven't been defined are disabled (undefined), but any NV bit images before that are enabled. • The d indicates the definition data. In data (d) a 1 bit specifies a dot to be printed and a 0 bit specifies a dot not to be printed. • This command defines n as the number of a NV bit image. Numbers rise in order from NV bit image 01H. Therefore, the first data group [xL xH yL yH d1...dk] is NV bit image 01H, and the last data group [xL xH yL yH d1...dk] is NV bit image n. The total agrees with the number of NV bit images specified by command 0x1C 0x70. • A definition data of a NV bit image consists of [xL xH yL yH d1...dk]. Therefore, when only one NV bit image is defined, n = 0x01. 				



- The device processes a data group [xL xH yL yH d1...dk] once.
- The device uses $([\text{data: } (xL + xH \times 256) \times (yL + yH \times 256) \times 8] + [\text{header :4}])$ bytes of non-volatile memory.
- The definition area in this device is a maximum of 3 MB. This command can define several NV bit images, but cannot define a bit image data whose total capacity [bit image data + header] exceeds 3 MB.
- When this command is received during macro definition, the device ends macro definition, and begins executing this command.
- Once a NV bit image is defined, it is not erased by executing `0x1B 0x40`, reset, and power off.
- This command executes only definition of a NV bit image and does not execute printing. Printing of the NV bit image is executed by the `0x1C 0x70` command.

[Default]

[Reference] `0x1C 0x70`

[Example] To make a image or logo of width = 512 dots and height = 768 dots the command sequence to send is:
`0x1C 0x71 0x01 0x40 0x00 0x60 0x00` followed by 49152 bytes which define the image as the following drawing:

When $xL = 64, xH = 0,$
 $yL = 96, yH = 0$

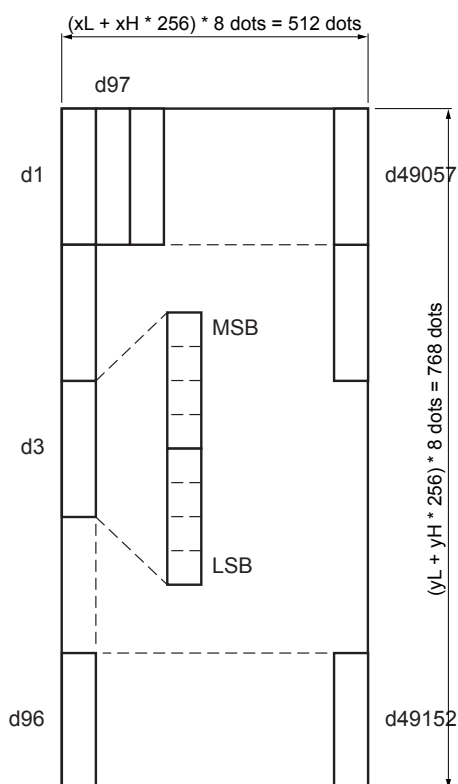



0x1D 0x2A

<GS *>

Define received bit image

Valid for	TG1260HIII TG2460HIII, TG2460HIII EJC TG2480HIII TL60III TL80III
-----------	--

[Format]	Hex	1D	2A	x	y	d1...d(x × y × 8)
	ASCII	GS	*	x	y	d1...d(x × y × 8)

[Range]	0x01 ≤ x ≤ 0xFF 0x01 ≤ y ≤ 0x30 x × y ≤ 1536 0x00 ≤ d ≤ 0xFF
---------	---

[Description]	Defines a received bit image using the number of dots specified by x and y. <ul style="list-style-type: none"> • x specifies the number of bytes in the horizontal direction. • y specifies the number of bytes in the vertical direction.
---------------	--

[Notes]	<ul style="list-style-type: none"> • The number of bytes in horizontal and vertical directions (x and y) are the horizontal and vertical size of the starting image divided by 8. • If x × y is out of the specified range, this command is disabled. • The d indicates bit-image data. Data (d) specifies a bit printed to 1 and not printed to 0. • The received bit image definition is cleared when: <ul style="list-style-type: none"> - 0x1B 0x40 is executed. - 0x1B 0x26 is executed. - Device is reset or the power is turned off. • The image is saved in the graphic memory of the device.
---------	--

[Default]

[Reference]



[Example]

The following figure shows the relationship between the received bit image and the printed data.

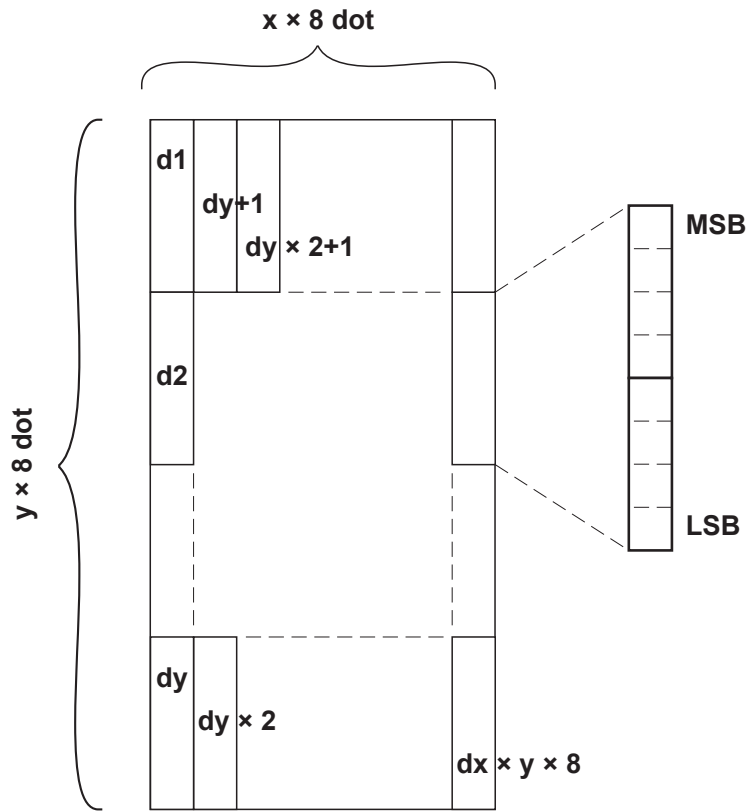



0x1D 0x2F

<GS />

Print received bit image

Valid for TG1260HIII
TG2460HIII, TG2460HIII EJC
TG2480HIII
TL60III
TL80III

[Format] Hex 1D 2F m
ASCII GS / m

[Range] $0x00 \leq m \leq 0x03$
 $0x30 \leq m \leq 0x33$

[Description] Prints a received bit image using the mode specified by m as follows:

m	MODE
0x00, 0x30	Normal
0x01, 0x31	Double width
0x02, 0x32	Double height
0x03, 0x33	Quadruple

[Notes]

- This command is ignored if a received bit image has not been defined.
- In standard mode, this command is effective only when there is no data in the print buffer.
- This command has no effect in the print modes bold, underline, character size, or white/black reverse printing), except for upside-down printing mode (180° rotation).
- If the received bit-image to be printed exceeds the printable area, the excess data is not printed.
- If the printing area width set by [0x1D 0x4C](#) and [0x1D 0x57](#) is less than one line in vertical, the following processing is performed only on the line in question:
 - 1) The printing area width is extended to the right up to one line in vertical. In this case, printing does not exceed the printable area.
 - 2) If the printing area width cannot be extended by one line in vertical, the left margin is reduced to accommodate one line in vertical.

[Default]

[Reference] [0x1D 0x2A](#)

[Example]



0x1D 0x76 0x30

<GS v 0>

Print raster bit image

Valid for	TG1260HIII TG2460HIII, TG2460HIII EJC TG2480HIII TL60III TL80III
-----------	--

[Format]	Hex	1D	76	30	m	xL xH yL yH d1...dk
	ASCII	GS	v	0	m	xL xH yL yH d1...dk

[Range]

$0x00 \leq m \leq 0x03$, $0x30 \leq m \leq 0x31$
 $0x00 \leq xL \leq 0xFF$
 $0x00 \leq xH \leq 0xFF$ ($1 \leq xL + xH \times 256 \leq 65535$)
 $0x00 \leq yL \leq 0xFF$
 $0x00 \leq yH \leq 0x08$ ($1 \leq yL + yH \times 256 \leq 2047$)
 $0x00 \leq d \leq 0xFF$
 $k = (xL + xH \times 256) + (yL + yH \times 256)$
(except for $k = 0$)

[Description] Selects raster bit image mode. The value of m selects the mode as follows:

m	MODE
0x00, 0x30	Normal
0x01, 0x31	Double width
0x02, 0x32	Double height
0x03, 0x33	Quadruple

- xL, xH selects the number of data bytes ($xL + xH \times 256$) in the horizontal direction for the bit image.
- yL, yH selects the number of data bytes ($yL + yH \times 256$) in the vertical direction for the bit image.
- k shows the number of data of the image. It's an explanation parameter so it isn't necessary to transmit it.
- d shows the data of the image.

- [Notes]
- In standard mode for receipt paper, this command is effective only when there is no data in the print buffer.
 - The data (d) identify as 1 a printed bit and as 0 a non printed bit.
 - If a raster bit image is longer than one line, the surplus data aren't printed.
 - This command has no effect in all print modes (character size, bold, upside-down, underline, white/black reverse printing, etc.) for raster bit image, except the reverse mode (90° anticlockwise rotation).
 - This command feed the paper as much as is necessary to print the raster bit image, though the spacing set by [0x1B 0x32](#) or [0x1B 0x33](#).



- Don't use this command during a macro execution because it can't be included in a macro.
- After the printing, the printing position moves to the beginning of the line.
- The following table shows the relationship between the downloaded bit image and the printed data:

d1	d2	...	dx
dX+1	dX+2	...	dX x 2
:	:	...	:
...	dk-2	dk-1	d

[Default]

[Reference]

[Example]



PRINT POSITION COMMANDS

0x08

<BS>

Back space

Valid for	TG1260HIII
	TG2460HIII, TG2460HIII EJC
	TG2480HIII
	TL60III
	TL80III

[Format]	Hex	08
	ASCII	BS

[Range]

[Description] Moves print position to previous character.

[Notes] This command can be used to put two characters at the same position.

[Default]

[Reference]

[Example]

0x09

<HT>

Horizontal tab

Valid for
 TG1260HIII
 TG2460HIII, TG2460HIII EJC
 TG2480HIII
 TL60III
 TL80III

[Format] Hex 09
 ASCII HT

[Range]

[Description] Moves the print position to the next horizontal tab position.

[Notes]

- Horizontal tab position are set using [0x1B 0x44](#).
- Ignored unless the next horizontal tab position has been set.
- If the command is received when the printing position is at the right margin, the device executes print buffer full printing and horizontal tab processing from the beginning of the next line.

[Default] Default tab positions are set at intervals of 8 characters (9, 17, 25, ...) when the right-side character spacing is 0.

[Reference] [0x1B 0x44](#)

[Example]

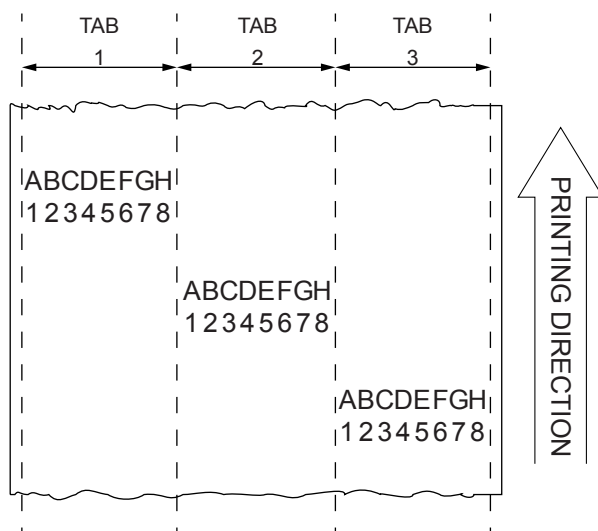



0x1B 0x24

<ESC \$>

Set absolute print position

Valid for	TG1260HIII TG2460HIII, TG2460HIII EJC TG2480HIII TL60III TL80III
-----------	--

[Format]	Hex 1B 24 nL nH ASCII ESC \$ nL nH
[Range]	0x00 ≤ nL ≤ 0xFF 0x00 ≤ nH ≤ 0xFF
[Description]	Sets the distance from the beginning of the line to the position at which subsequent characters are to be printed. The distance from the beginning of the line to the print position is [(nL + nH × 256) × (vertical or horizontal motion unit)].
[Notes]	<ul style="list-style-type: none">• Settings outside the specified printable area are ignored.• The horizontal and vertical motion unit are specified by 0x1D 0x50.• 0x1D 0x50 can change the horizontal (and vertical) motion unit. However, the value cannot be less than the minimum horizontal movement amount.• In standard mode, the horizontal motion unit (x) is used.• If the setting is outside the printing area width, it sets the absolute print position, but the left or right margin is set at default value.
[Default]	
[Reference]	0x1B 0x5C , 0x1D 0x50
[Example]	



0x1B 0x28 0x76

<ESC (v>

Set relative vertical print position

Valid for	TG1260HIII TG2460HIII, TG2460HIII EJC TG2480HIII TL60III TL80III					
[Format]	Hex	1B	28	76	nL	nH
	ASCII	ESC	(v	nL	nH
[Range]	0x00 ≤ nL ≤ 0xFF 0x00 ≤ nH ≤ 0xFF					
[Description]	Sets the print vertical position based on the current position by using the horizontal or vertical motion unit. This command sets the distance from the current position to [(nL + nH × 256) × horizontal or vertical motion unit].					
[Notes]	<ul style="list-style-type: none"> • When the starting position is specified by N motion unit to the bottom: $nL + nH \times 256 = N$. • When the starting position is specified by N motion unit to the top (negative direction), use the complement of 65536: $nL + nH \times 256 = 65536 - N$. • The horizontal and vertical motion unit are specified by 0x1D 0x50. • The 0x1D 0x50 command can change the horizontal (and vertical) motion unit. However, the value cannot be less than the minimum horizontal movement amount. • In standard mode, the vertical motion unit is used. 					
[Default]						
[Reference]	0x1D 0x50					
[Example]						



0x1B 0x44

<ESC D>

Set horizontal tab positions

Valid for	TG1260HIII TG2460HIII, TG2460HIII EJC TG2480HIII TL60III TL80III
-----------	--

[Format]	Hex 1B 44 n1...nk 00 ASCII ESC D n1...nk NUL
----------	--

[Range]	0x01 ≤ n ≤ 0xFF 0x00 ≤ k ≤ 0x20
---------	------------------------------------

[Description]	Sets horizontal tab positions <ul style="list-style-type: none"> • n specifies the column number for setting a horizontal tab position calculated from the beginning of the line. • k indicates the total number of horizontal tab positions to be set.
---------------	---

[Notes]	<ul style="list-style-type: none"> • The horizontal tab position is stored as a value of [character width × n] measured from the beginning of the line. The character width includes the right-side character spacing and double-width characters are set with twice the width of normal characters. • This command cancels previous tab settings. • Up to 32 tab positions (k = 0x20) can be set. Data exceeding 32 tab positions is processed as normal data. • Send [n] k in ascending order and place a 0 NUL code at the end. When [n] k is less than or equal to the preceding value [n] k-1, the setting is complete and the data which follows is processed as normal data. • 0x1B 0x44 0x00 cancels all horizontal tab positions. • The previously specified horizontal tab position does not change, even if the character width is modified.
---------	---

[Default]	Default tab positions are set at intervals of 8 characters (columns 9, 17, 25, ...) when the right-side character spacing is 0.
-----------	---

[Reference]	0x09
-------------	------



[Example]

To set a tabulation to column 4 send the command:

0x1B 0x44 0x03 0x00

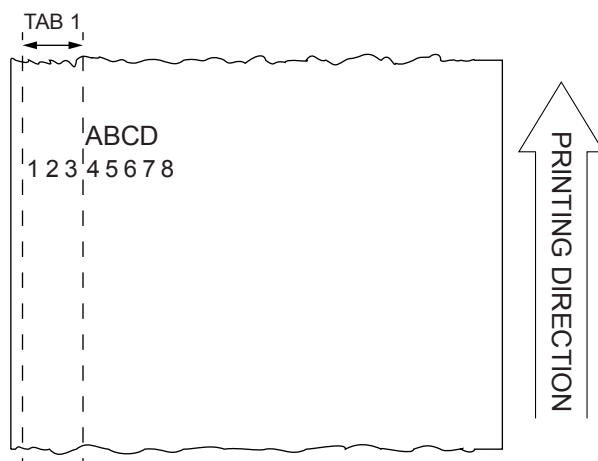

To print the string 'ABCD' to the tabulation previously set, the command sequence is:

0x09 'ABCD'

where:

0x09 move the print position to the set horizontal tab (4th column).

'ABCD' is the string to be printed.



0x1B 0x5C

<ESC I>

Set relative print position

Valid for	TG1260HIII TG2460HIII, TG2460HIII EJC TG2480HIII TL60III TL80III
-----------	--

[Format]	Hex 1B 5C nL nH ASCII ESC \ nL nH
----------	--

[Range]	0x00 ≤ nL ≤ 0xFF 0x00 ≤ nH ≤ 0xFF
---------	--------------------------------------

[Description]	Sets the print starting position based on the current position by using the horizontal or vertical motion unit. Sets the distance from the current position to [(nL + nH × 256) × horizontal or vertical motion unit].
---------------	---

[Notes]	<ul style="list-style-type: none">• When the starting position is specified by N motion units to the right: nL + nH × 256 = N.• When the starting position is specified by n motion units to the left (negative direction), use the complement of 65536: nL + nH × 256 = 65536 – N.• If setting exceeds the printing area width, the left or right margin is set to the default value.• The horizontal and vertical motion unit are specified by 0x1D 0x50.• 0x1D 0x50 can change the horizontal (and vertical) motion units. However, the value cannot be less than the minimum horizontal movement amount.• In standard mode, the horizontal motion unit is used.• It's possible to print further on the right margin set for every font. In this case the printing continues up to the maximum border of the device mechanism and then begins a new row.
---------	---

[Default]

[Reference]	0x1B 0x24 , 0x1D 0x50
-------------	---

[Example]

0x1B 0x61

<ESC a>

Select justification

Valid for
 TG1260HIII
 TG2460HIII, TG2460HIII EJC
 TG2480HIII
 TL60III
 TL80III

[Format] Hex 1B 61 n
 ASCII ESC a n

[Range] 0x00 ≤ n ≤ 0x02
 0x30 ≤ n ≤ 0x32

[Description] This command selects the type of justification based on the value of n as follows:

n	JUSTIFICATION
0x00, 0x30	Left justification
0x01, 0x31	Centered
0x02, 0x32	Right justification

[Notes]

- Lines are justified within the specified printing area.
- Spaces set by 0x09, 0x1B 0x24 and 0x1B 0x5C will be justified according to the previously-entered mode.

[Default] n = 0x00

[Reference]

[Example]

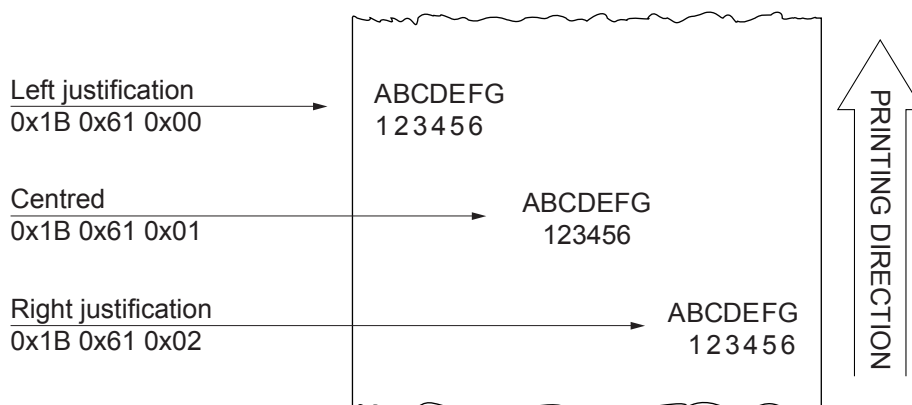

0x1D 0x4C

<GS L>

Set left margin

Valid for
 TG1260HIII
 TG2460HIII, TG2460HIII EJC
 TG2480HIII
 TL60III
 TL80III

[Format] Hex 1D 4C nL nH
 ASCII GS L nL nH

[Range] 0x00 ≤ nL, nH ≤ 0xFF

[Description] Sets the left margin to [(nL + nH × 256) × horizontal motion unit].

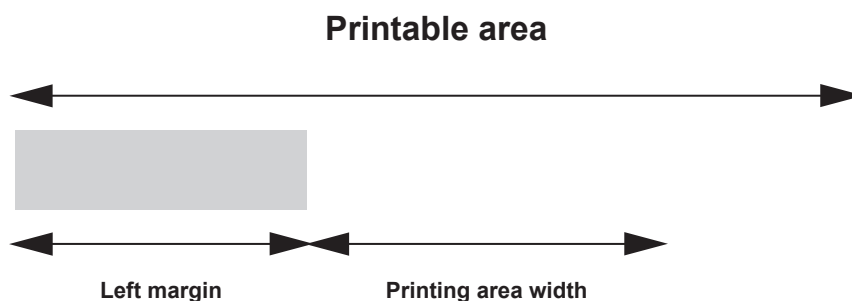

- [Notes]
- If the setting exceeds the printable area, the maximum value of the printable area is used.
 - If the left margin + printing area width is greater than the printable area, the printing area width is set at maximum value.
 - The horizontal and vertical motion unit are specified by [0x1D 0x50](#). Changing the horizontal or vertical motion unit does not affect the current left margin.
 - The [0x1D 0x50](#) command can change the horizontal (and vertical) motion unit.
 - However, the value cannot be less than the minimum horizontal movement amount and it must be in even units of the minimum horizontal movement amount.

[Default]

[Reference] [0x1D 0x50](#), [0x1D 0x57](#)

[Example]

0x1D 0x57

<GS W>

Set printing area width

Valid for	TG1260HIII
	TG2460HIII, TG2460HIII EJC
	TG2480HIII
	TL60HIII
	TL80HIII

[Format]	Hex	1D	57	nL	nH
	ASCII	GS	W	nL	nH

[Range]	$0x00 \leq nL, nH \leq 0xFF$
	$0 \leq (nL + nH \times 256) \leq 640$

[Description] Sets the printing area width to the area specified by nL and nH. The left margin is set to $[(nL + nH \times 256) \times (\text{horizontal motion unit})]$ inches.

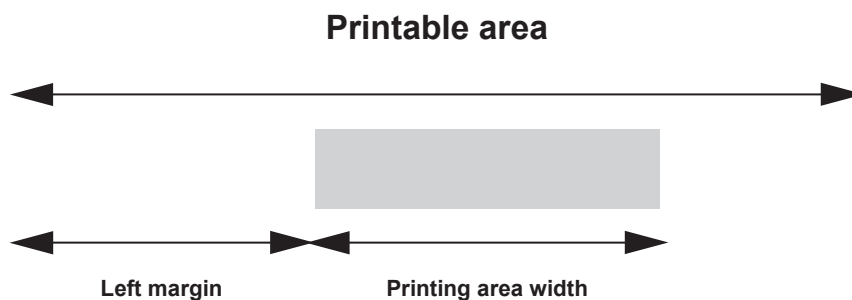

- [Notes]
- This command is only enabled if set at the beginning of the line.
 - If the right margin is greater than the printable area, the printing area width is set at maximum value.
 - If the printing area width = 0, it is set at the maximum value.
 - The horizontal and vertical motion units are specified by [0x1D 0x50](#). Changing the horizontal or vertical motion unit does not affect the current left margin.
 - The [0x1D 0x50](#) command can change the horizontal (and vertical) motion unit. However, the value cannot be less than the minimum horizontal movement amount and it must be in even units of the minimum horizontal movement amount.

[Default]

[Reference] [0x1D 0x4C](#), [0x1D 0x50](#)

[Example]



MACRO FUNCTIONS CONTROL

0x1D 0x3A

<GS :>

Start or end of macro definition

Valid for

- TG1260HIII
- TG2460HIII, TG2460HIII EJC
- TG2480HIII
- TL60III
- TL80III

[Format]

Hex	1D	3A
ASCII	GS	:

[Range]

[Description] Starts or ends macro definition.

[Notes]

- Macro definition starts when this command is received during normal operation.
- When [0x1D 0x5E](#) is received during macro definition, the device ends macro definition and clears all definitions.
- Macros are not defined when power is turned on to the machine.
- Macro content is not cancelled by the [0x1B 0x40](#) command. Therefore, [0x1B 0x40](#) may be included in the content of macro definitions.
- If the device receives [0x1D 0x3A](#) a second time after previously receiving [0x1D 0x3A](#), the device remains in macro undefined status.
- The contents of the macro can be defined up to 1024 bytes. If the macro definition exceeds 1024 bytes, excess data is not stored.

[Default]

[Reference] [0x1D 0x5E](#)

[Example]



0x1D 0x5E

<GS ^>

Execute macro

Valid for	TG1260HIII TG2460HIII, TG2460HIII EJC TG2480HIII TL60III TL80III					
[Format]	Hex	1D	5E	r	t	m
	ASCII	GS	^	r	t	m
[Range]	0x00 ≤ r, t ≤ 0xFF 0x00 ≤ m ≤ 0x01					
[Description]	<p>Executes a macro.</p> <ul style="list-style-type: none"> • r specifies the number of times to execute the macro. • t specifies the waiting time for executing the macro. The waiting time is t × 100 ms for each macro execution. • m specifies macro executing mode: When the Least Significant Bit (LSB) of m = 0, the macro is executed r times continuously at the interval specified by t. When the Least Significant Bit (LSB) of m = 1, after waiting for the period specified by t, the LED indicator blinks and the device waits for the FEED button to be pressed. After the button is pressed, the device executes the macro once. The device repeats the operation r times. 					
[Notes]	<ul style="list-style-type: none"> • This command has an interval of (t × 100 ms) after a macro is executed by t. • If this command is received while a macro is being defined, the macro definition is aborted and the definition is cleared. • If the macro is not defined or if r is 0x00, nothing is executed. • When the macro is executed by pressing the FEED button (m = 0x01), the paper cannot be fed using the FEED button. 					
[Default]						
[Reference]	0x1D 0x3A					
[Example]						



COMMANDS FOR MECHANISM CONTROL

0x1B 0x69

<ESC i>

Total cut

Valid for	TG1260HIII
	TG2460HIII, TG2460HIII EJC
	TG2480HIII
	TL60III
	TL80III

[Format]	Hex	1B	69
	ASCII	ESC	i

[Range]

[Description] This command enables autocutter operation and executes a total cut.

[Notes] The device waits to complete all paper movement commands before it executes a total cut.

[Default]

[Reference]

[Example]



0x1B 0x6D

<ESC m>

Partial cut

Valid for	TL60III		
[Format]	Hex	1B	6D
	ASCII	ESC	m
[Range]			
[Description]	This command enables autocutter operation and executes a partial cut.		
[Notes]	The device waits to complete all paper movement commands before it executes a partial cut.		
[Default]			
[Reference]			
[Example]			



0x1C 0xC0 0x34

Total cut and automatic paper moving back

Valid for
TG1260HIII
TG2460HIII, TG2460HIII EJC
TG2480HIII
TL60III
TL80III

[Format] Hex 1C C0 34
 ASCII FS 0xC0 4

[Range]

[Description] This command enables autocutter operation and executes a total cut and automatic paper moving back; if there is no autocutter, a disabling flag is set any subsequent cutting commands will be ignored.

[Notes] The device waits until all the paper movement commands have been completed before executing total cut.
 After cutting, the ticket is set back to the printing line.

[Default]

[Reference]

[Example]



0x1D 0x56

<GS V>

Select cut mode

Valid for TG1260HIII
 TG2460HIII, TG2460HIII EJC
 TG2480HIII
 TL60III
 TL80III

[Format] Hex 1D 56 m
 ASCII GS V m

[Range] m = 0x00, 0x30, 0x41, 0x42

[Description] Selects cut mode and executes the cut command based on the value of m as follows:

m	FUNCTION
0x00, 0x30	Total cut
0x41, 0x42	Form feed (cut position + [n × vertical motion unit]) and total cut

[Notes]

- This command is only enabled if set at the beginning of the line.
- The horizontal and vertical motion units are specified by [0x1D 0x50](#).

[Default]

[Reference] [0x1B 0x69](#), [0x1D 0x50](#)

[Example]



ALIGNMENT COMMANDS

0x1D 0xE7

Set black mark distance

Valid for	TG1260HIII TG2460HIII, TG2460HIII EJC TG2480HIII TL60III TL80III
-----------	--

[Format]	Hex 1D E7 nL nH ASCII GS 0xE7 nL nH
[Range]	0x00 ≤ nH ≤ 0xFF 0x00 ≤ nL ≤ 0xFF
[Description]	Sets black mark distance in tenth of millimeter of the alignment point from the edge of the black mark. This value is expressed as [(nH × 256) + nL] where: - if nH ≤ 0x7F , the value will be positive. - if nH > 0x7F , the value will be negative.
[Notes]	<ul style="list-style-type: none">• The maximum value is 99.9 mm.• The minimum value is -19.9 mm.• The distance is saved in nonvolatile memory: it is therefore recommended not to send this command for each printed ticket, because the number of rewrites is limited. In many devices, however, is checked the diversity of the data before performing the rescue to avoid reaching the limit of rewrites.• The distance defined by this command is the same that can be set with the value of the “Black Mark Distance” during the setup of the device (see user manual for further explanation).
[Default]	nH = 0x00 nL = 0x00
[Reference]	

[Example]

To set a distance of the alignment point from the black mark equal to 8 mm = 80 tenths of a millimeter, send the command:

0x1D 0xE7 0x00 0x50

where:

0x00 the most significant bit (MSB = 0) defines the sign +

0x00 0x50 the absolute value defines the distance = 80 tenths of a millimeter

To set a distance of the alignment point from the black mark equal to - 8 mm, send the command:

0x1D 0xE7 0x80 0x50

where:

0x80 the most significant bit (MSB = 1) defines the sign -

0x80 0x50 the absolute value defines the distance = 80 tenths of a millimeter

The following images show tickets with alignment point positioned at 8 mm and -8 mm from the black mark.

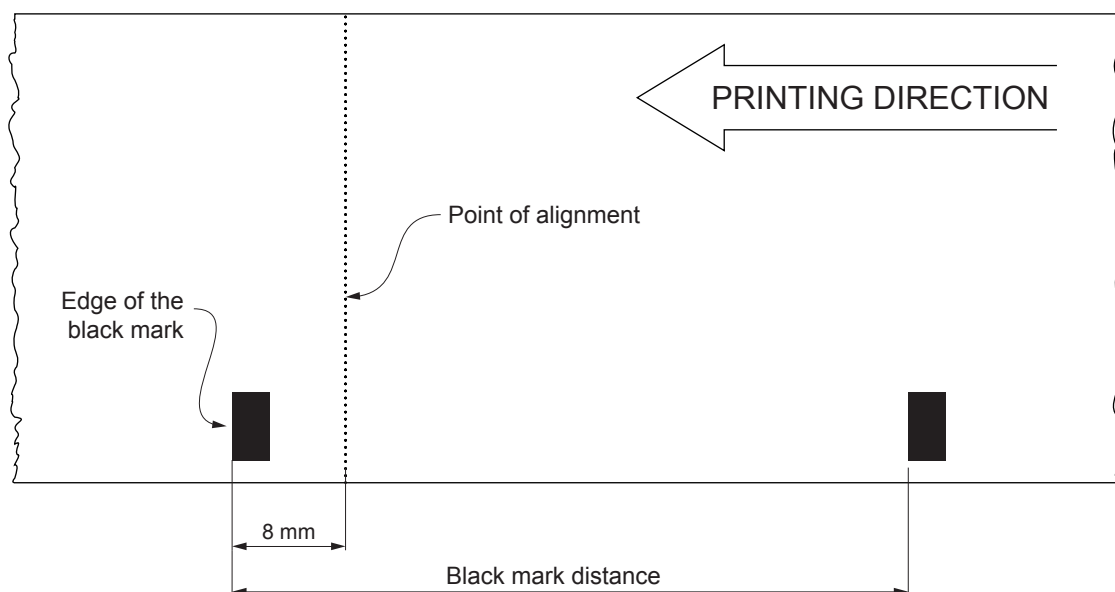
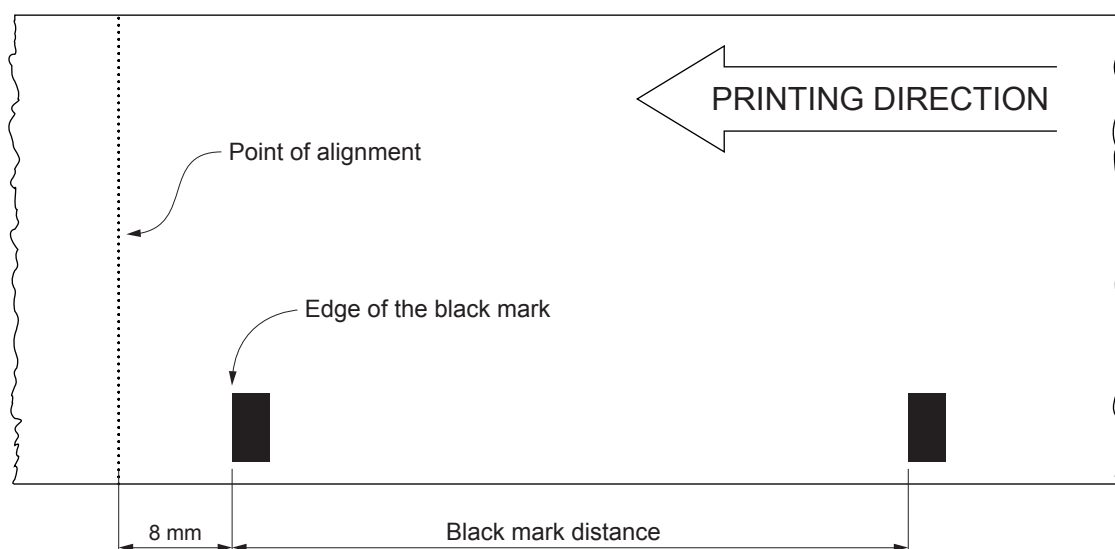



0x1D 0xF6

Align the ticket with the printhead

Valid for	TG1260HIII TG2460HIII, TG2460HIII EJC TG2480HIII TL60III TL80III
-----------	--

[Format]	Hex	1D	F6
	ASCII	GS	0xF6

[Range]

[Description] This command align the edge of black mark to the alignment point (see [ALIGNMENT](#) section for further explanation).

- [Notes]
- Use [0x1D 0xE7](#) command to set the distance between the edge of black mark and the alignment point.
 - To work properly, the “Black Mark Position” parameter must be enabled during the setup procedure (refer to the user manual of each device).
 - Use this alignment command even to print more tickets without cutting.

[Default]

[Reference] [0x1D 0xE7](#), [0x1D 0xF8](#)

[Example]



0x1D 0xF8

Align the ticket with the autocutter

Valid for	TG1260HIII TG2460HIII, TG2460HIII EJC TG2480HIII TL60III TL80III
-----------	--

[Format]	Hex	1D	F8
	ASCII	GS	0xF8

[Range]

[Description] This command align the edge of the black mark to the alignment point (see [ALIGNMENT](#) section for further explanation).

[Notes]

- Use [0x1D 0xE7](#) command to set distance between the edge of the ticket and the alignment point.
- To work properly, the “Black Mark Position” parameter must be enabled during the setup procedure (refer to the user manual of each device).
- Use this alignment command even to print more tickets without cutting.

[Default]

[Reference] [0x1D 0xE7](#), [0x1D 0xF6](#)

[Example]



EJECTOR COMMANDS

0x1C 0x50

<FS P>

Ejector management

Valid for TG2460HIII EJC

[Format] Hex 1C 50 a b
 ASCII FS P a b

[Range] a = 0x00, 0x01
 0x00 ≤ b ≤ 0xFF

[Description] This command cuts the paper and present/retract the ticket according to a value as described in the following table:

a	FUNCTION
0x00	Eject printed ticket
0x01	Present printed ticket

If a = 0x01, b indicates the timeout (in seconds) for the ticket ejection (0x01 = 1 second).

[Notes]

[Default] a = 0x00

[Reference]

[Example]

a = 0x00

The device starts the ticket printing.

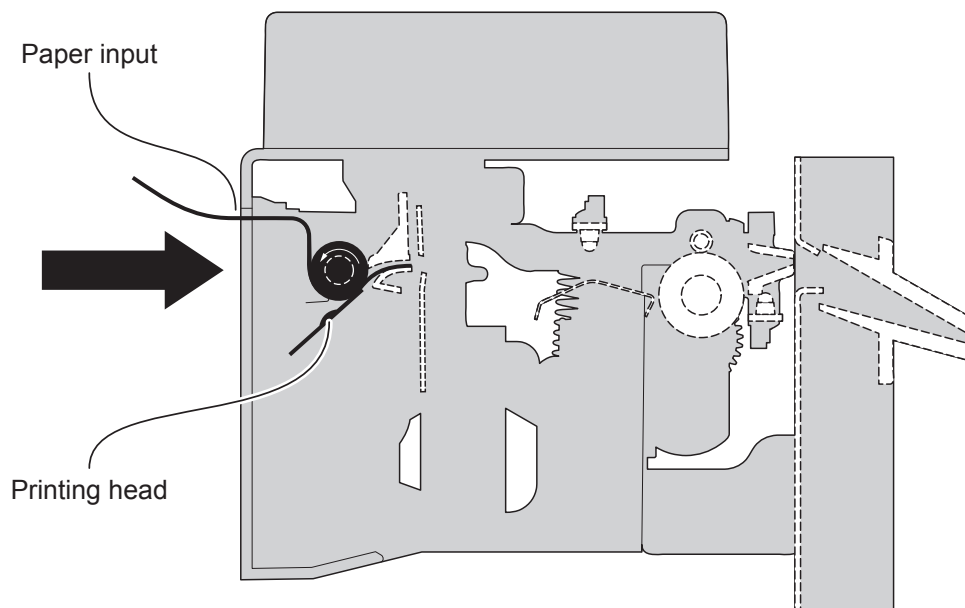

The ticket advances ahead to engage the ejector sensor and is caught between the ejector rollers. The printed portion of ticket is collected in the space between autocutter and ejector while the device continues printing.

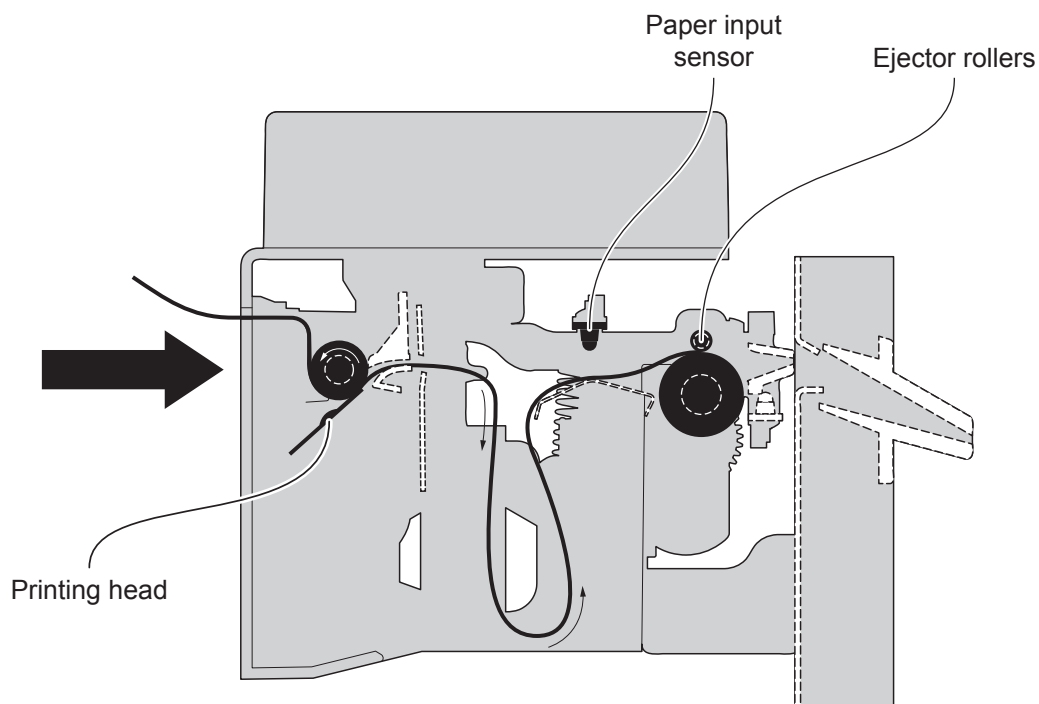



When printing ends, the device cuts the ticket printed.

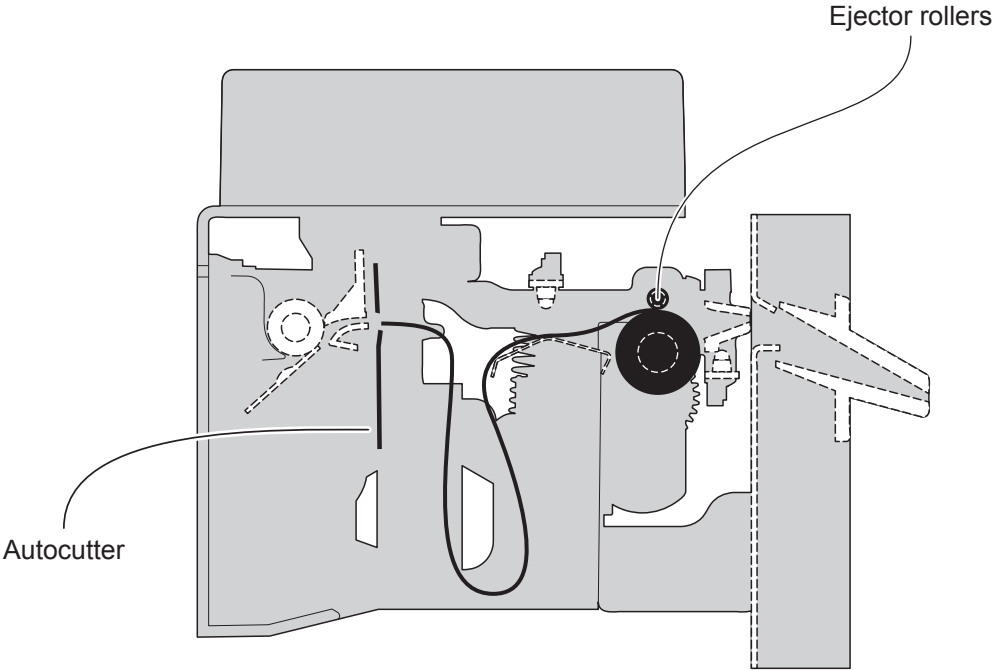

The device directly ejects the ticket.

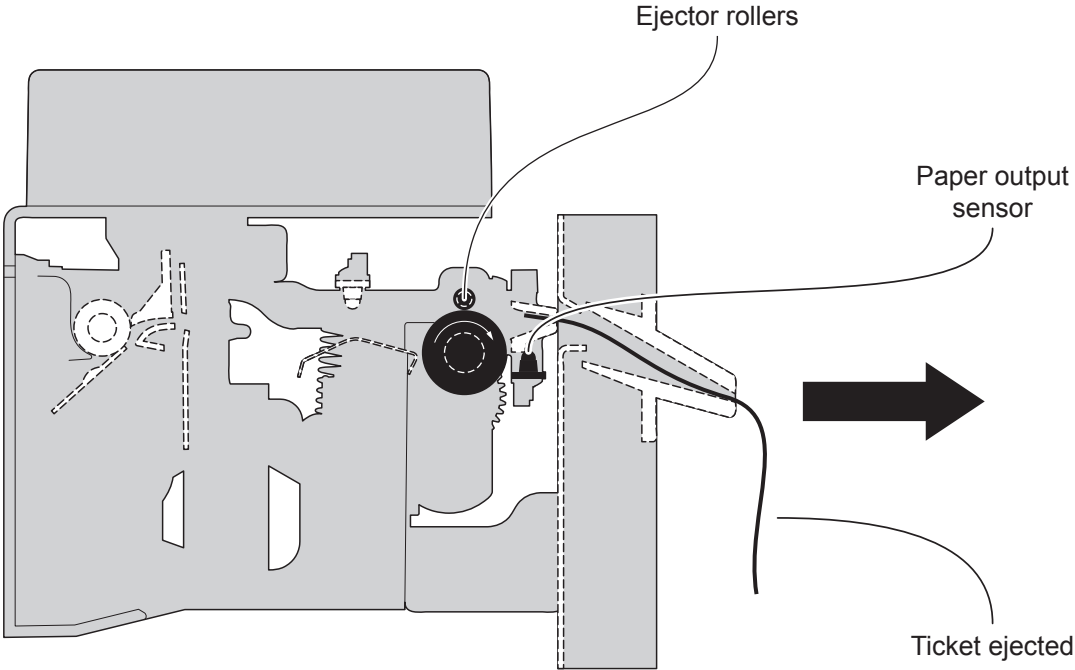

a = 0x01

The device starts the ticket printing.

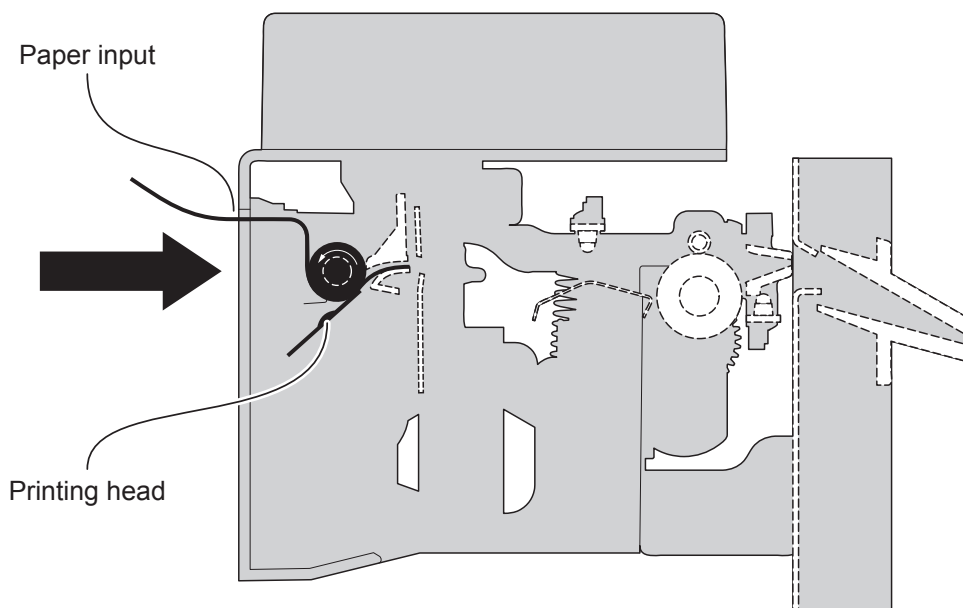

The ticket advances ahead to engage the ejector sensor and is caught between the ejector rollers. The printed portion of ticket is collected in the space between autocutter and ejector while the device continues printing.

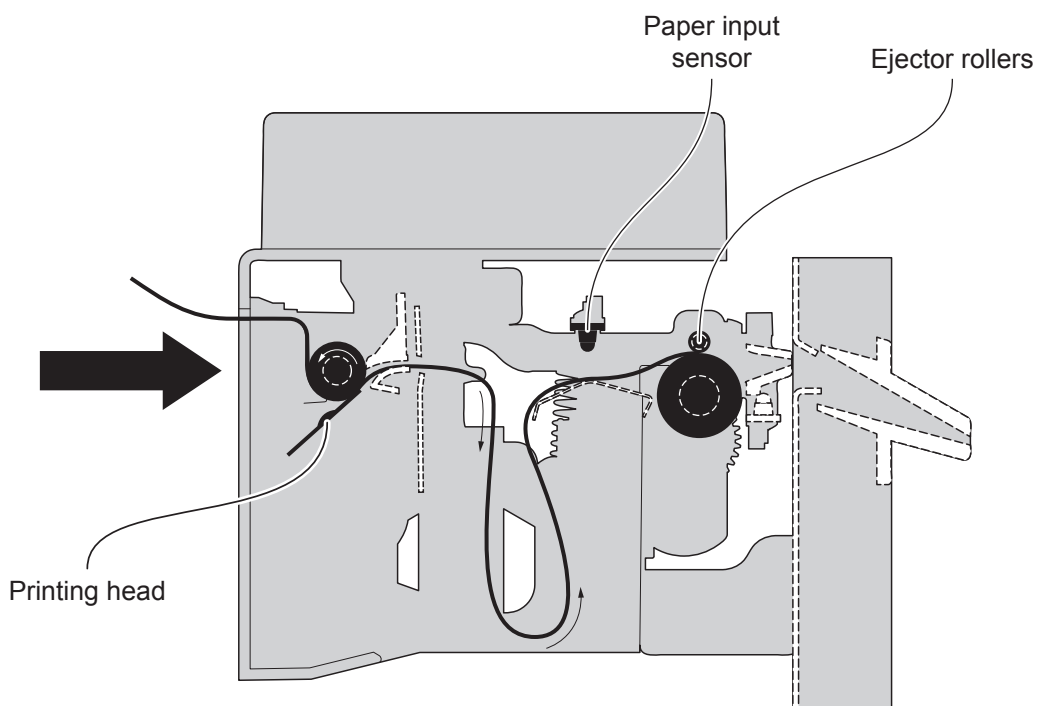



When printing ends, the device cuts the ticket printed.

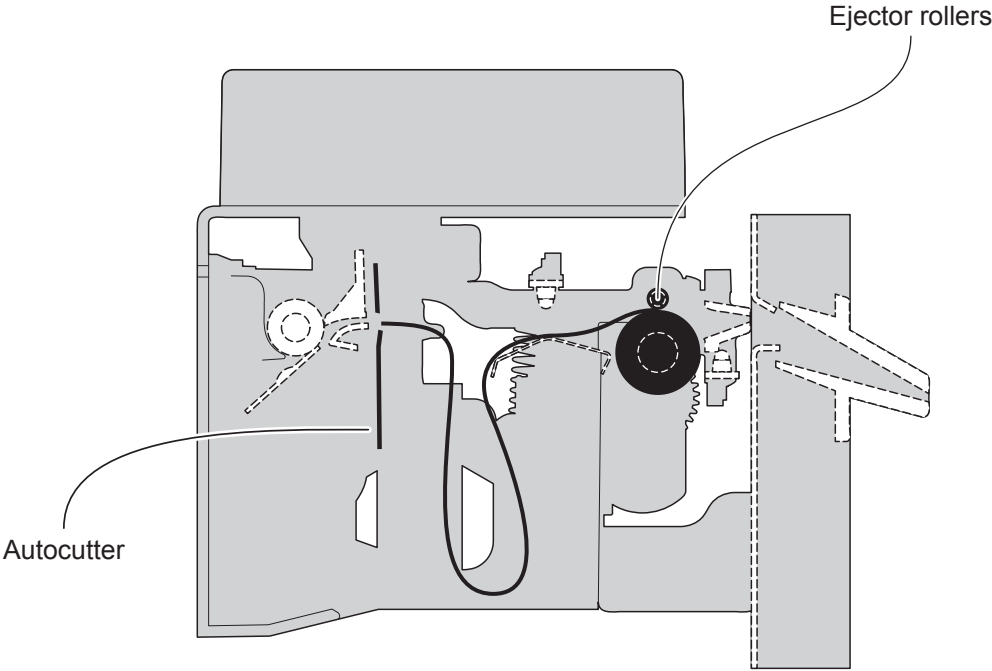

The device presents a portion of the ticket printed on the paper mouth.

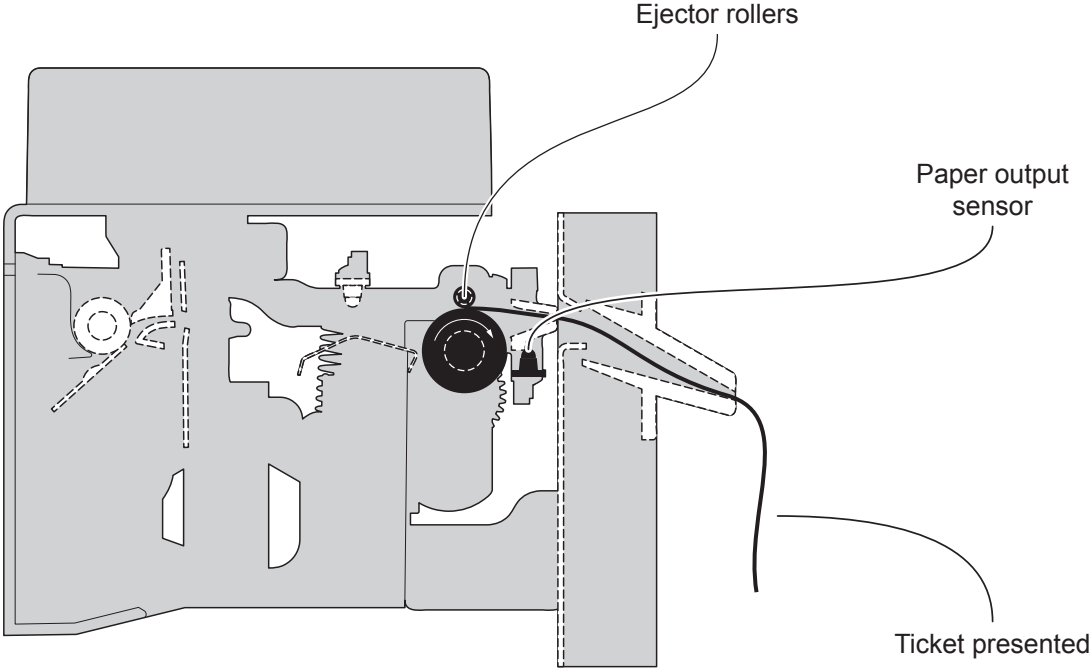

The ticket is waiting on the paper mouth for a preset period of time.



The device directly ejects the ticket.

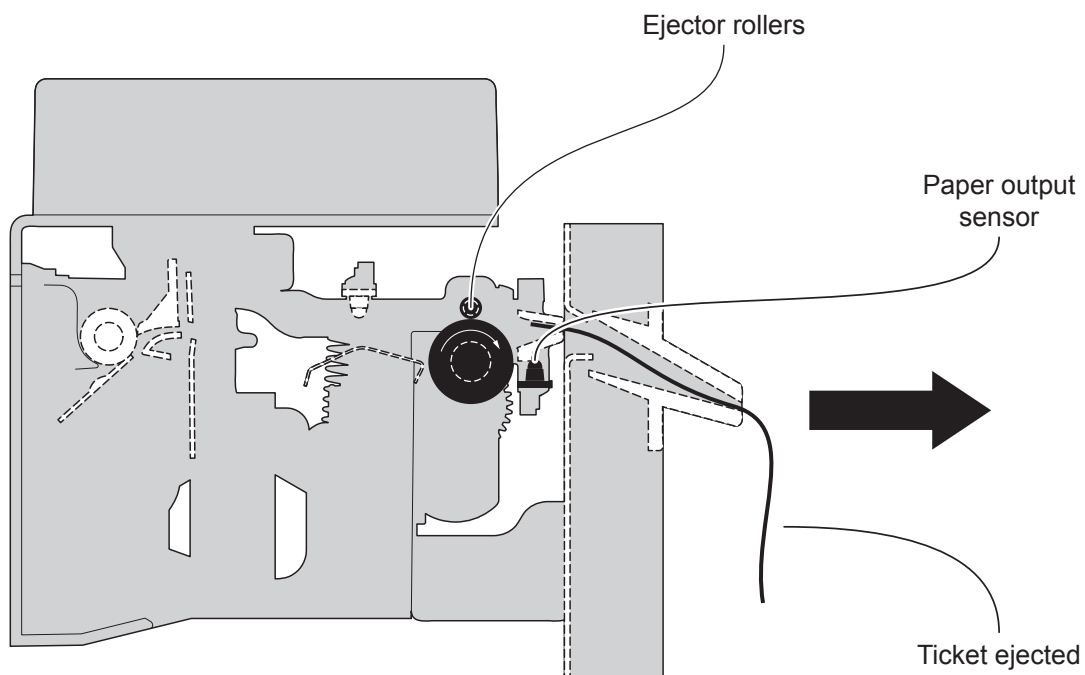



MISCELLANEOUS COMMANDS

0x1B 0x3D

<ESC =>

Select peripheral device

Valid for

- TG1260HIII
- TG2460HIII, TG2460HIII EJC
- TG2480HIII
- TL60III
- TL80III

[Format]

Hex	1B	3D	n
ASCII	ESC	=	n

[Range] 0x01 ≤ n ≤ 0x03

[Description] Select the device to which the host computer sends data, using n as follows:

n	FUNCTION
0x01, 0x03	Device enabled
0x02	Device disabled

[Notes] When the device is disabled, it ignores all transmitted data until the device is enabled through this command.

[Default] n = 0x01

[Reference]

[Example]



0x1B 0x40

<ESC @>

Initialize device

Valid for	TG1260HIII
	TG2460HIII, TG2460HIII EJC
	TG2480HIII
	TL60III
	TL80III

[Format]	Hex	1B	40
	ASCII	ESC	@

[Range]

[Description] Clears the data in the print buffer and resets the device mode to that in effect when power was turned on.

[Notes]

- The data in the receiver buffer is not cleared.
- The macro definitions are not cleared.

[Default]

[Reference]

[Example]



0x1B 0x63 0x35

<ESC c 5>

Enable or disable keys panel

Valid for TG1260HIII
TG2460HIII, TG2460HIII EJC
TG2480HIII
TL60III
TL80III

[Format] Hex 1B 63 35 n
ASCII ESC c 5 n

[Range] $0x00 \leq n \leq 0xFF$

[Description] Enables or disables the keys panel, based on the value of n
- when the Least Significant Bit (LSB) of n is 0, the keys panel is enabled.
- when the Least Significant Bit (LSB) of n is 1, the keys panel is disabled.

[Notes]

- Only the Least Significant Bit (LSB) of n is effective.
- When the keys panel is disabled, the keys may only be used after the device has been reset.

[Default] n = 0x00

[Reference]

[Example]



0x1C 0x3C

<FS >

Change emulation

Valid for TG1260HIII
 TG2460HIII, TG2460HIII EJC
 TG2480HIII
 TL60III
 TL80III

[Format] Hex 1C 3C
 ASCII FS <

[Range]

[Description] Change device emulation.

[Notes]

[Default]

[Reference]

[Example]



0x1C 0x80

Read date/time of the real time clock

Valid for
 TG1260HIII
 TG2460HIII, TG2460HIII EJC
 TG2480HIII
 TL60III
 TL80III

[Format] Hex 1C 80 m
 ASCII FS 0x80 m

[Range] 0x00 ≤ m ≤ 0x03

[Description] Read date/time of the real time clock in the format specified by m values as follows:

m	FORMAT
0x00	DD/MM/YY hh:mm:ss
0x01	DDMMYYhhmmss
0x02	YYMMDDhhmmss
0x03	YYMMDDkkmmssd

where:

DD represents the day of the date
 MM represents the month of the date
 YY represents the year of the date
 hh represents the hour of the time
 mm represents the minutes of the time
 ss represents the seconds of the time
 d represents the day of the week

[Notes] Before send the date/time, if the m parameter is valid the device transmits the ACK (0x06) followed by the number of bytes to sent, otherwise return NACK (0x15).

[Default]

[Reference]

[Example] To read date/time in the “DDYYMMhhmmss” format, send the command sequence:
 0x1C 0x80 0x01

If the current date/time are “15 September 2006 at 10:56:20 (AM)”, the device answers as follows:
 in Hex: 0x06 0x0C 0x31 0x35 0x30 0x39 0x30 0x36 0x31 0x30 0x35 0x36 0x32 0x30
 in ASCII: ACKFF150906105620



0x1C 0x81

Set date/time of the real time clock

Valid for	TG1260HIII TG2460HIII, TG2460HIII EJC TG2480HIII TL60III TL80III
-----------	--

[Format]	Hex	1C	81	m	n	d0...dn
	ASCII	FS	0x81	m	n	d0...dn

[Range] 0x00 ≤ m ≤ 0x03
0x00 ≤ d0, dn ≤ 0xFF

[Description] Set date/time of the real time clock in the format specified by m values as follows:

m	FORMAT
0x00	DD/MM/YY hh:mm:ss
0x01	DDMMYYhhmmss
0x02	YYMMDDhhmmss
0x03	YYMMDDkkmmssd

where:

DD represents the day of the date
MM represents the month of the date
YY represents the year of the date
hh represents the hour of the time
mm represents the minutes of the time
ss represents the seconds of the time
d represents the day of the week

- n specifies the number of characters to send.
- d0...dn are the ASCII characters relative to the date and time to set.

[Notes] • If the transmission has been received correctly and the command is valid, the device returns the ACK (0x06), otherwise returns NACK (0x15).
• The day of the week is calculated automatically from the device and then it's possible that the returned value is different from the one transmitted.

[Default]

[Reference]

[Example] To set the date and time to "29 September 2006 at 13:51:00 (PM)" in the "YYMMDDhhmmss" format, send the command sequence:
0x1C 0x81 0x02 0x0C 0x30 0x36 0x30 0x39 0x32 0x39 0x31 0x33 0x35 0x31 0x30 0x30



0x1C 0x84

Set user-defined date/time formats

Valid for	TG1260HIII TG2460HIII, TG2460HIII EJC TG2480HIII TL60III TL80III
-----------	--

[Format]	Hex 1C 84 n d1...dk 0x00 ASCII FS 0x84 n d1...dk NUL
----------	---

[Range]	n = 0x44, 0x54 0x00 ≤ d0, dK ≤ 0xFF
---------	--

[Description] Sets the format string for date and time used to printing.

- n specifies which user-defined string format is set:
 - 0x44 for date
 - 0x54 for time
- d0..dk are the ASCII characters relative to user-defined date/time formats.
- The maximum length of the user-defined date/time format string is 64 chars.
- The following table shows characters used to create user-defined date/time formats:

CHARACTER	DESCRIPTION
I	Select Italian language
E	Select English language (default language)
c	Select default data/time
d	Displays the day as a number without a leading zero (1-31)
dd	Displays the day as a number with a leading zero (01-31)
ddd	Displays the day as an abbreviation (for example, Sun)
dddd	Displays the day as a full name (for example, Sunday)
dddddd	Displays the date as a complete date in the short format where date values are formatted with day, month and year (the short date format is dd/mm/yy)
dddddd	Displays the date as a complete date in the extended format where date values are formatted with day, month and year (the extended date format is dd mmmm, yyyy)
m	Displays the month as a number without a leading zero (1-12). If the character m is immediately after the character h or hh ,displays the minutes instead of month (see also the n character formatting)
mm	Displays the month as a number with leading zeros (01-12). If the character m is immediately after the character h or hh , displays the minutes instead of month (see also the nn character formatting)
mmm	Displays the month as an abbreviation (for example, Jan)
mmmm	Displays the month as a full month name (for example, January)



yy	Displays the year in two-digit numeric format with a leading zero
yyyy	Displays the year in four digit numeric format
CHARACTER	DESCRIPTION
h	Displays the hour as a number without leading zeros (0-23)
hh	Displays the hour as a number with leading zeros (00-23)
n	Displays the minutes as a number without leading zeros (0-59)
nn	Displays the minutes as a number with leading zeros (00-59)
s	Displays the seconds as a number without leading zeros (0-59)
ss	Displays the seconds as a number with leading zeros (00-59)
tttt	Displays the time in the extended format where time values are formatted with hour, minutes and seconds (the extended time format is h:mm:ss).
AM/PM	Using the 12-hour clock and displays the AM prefix in uppercase next to the hours that preceding midday and the PM prefix in uppercase next to the hours between midday and midnight.
am/pm	Using the 12-hour clock and displays the am prefix in lowercase next to the hours that preceding midday and the pm prefix in lowercase next to the hours between midday and midnight.
A/P	Using the 12-hour clock and displays the A prefix in uppercase next to the hours that preceding midday and the a prefix in uppercase next to the hours between midday and midnight.
a/p	Using the 12-hour clock and displays the a prefix in lowercase next to the hours that preceding midday and the a prefix in lowercase next to the hours between midday and midnight.

[Notes] The device returns ACK (0x06) if the transmission is OK otherwise NACK (0x15).

[Default]

[Reference]

[Example] To print the current time with the string format 'yy/mm/dd hh:mm:ss' follow these steps:

1. Send the following command to define the user-defined time string format:
0x1C 0x84 0x54 0x79 0x79 0x2F 0x6D 0x6D 0x2F 0x64 0x64 0x20 0x68 0x68 0x3A 0x6E 0x6E 0x3A
0x73 0x73 0x00

2. Send the following command to print the time:
0x1C 0x83 0x0A

The character 0x0A feeds one line based on the current line spacing.
If the date and time is 22 October 2006 at 17:35:27 (PM) the output string printed will be:
06/10/22 17:35:27



0x1C 0xEF

Set device in low power mode

Valid for

- TG1260HIII
- TG2460HIII, TG2460HIII EJC
- TG2480HIII
- TL60III
- TL80III

[Format]

Hex	1C	EF	0xAE	0x01
ASCII	FS	0xEF	0XAE	SOH

[Range]

[Description] This command sets the device in low power mode.

[Note]

[Default]

[Reference]

[Example]



0x1D 0x49

<GS />

Transmit device ID

Valid for

TG1260HIII
 TG2460HIII, TG2460HIII EJC
 TG2480HIII
 TL60III
 TL80III

[Format]

Hex	1D	49	n
ASCII	GS	I	n

[Range]

$0x01 \leq n \leq 0x03$
 $0x31 \leq n \leq 0x33$
 $n = 0xFF$

[Description] Transmits the device ID specified by n follows:

n	DEVICE ID	SPECIFICATION
0x01, 0x31	Device model ID (1 byte)	0xFF (resend the command with n = 0xFF)
0x02, 0x32	Type ID	See table below
0x03, 0x33	ROM version ID (4 bytes)	Depends on ROM version (4 character)
0xFF	Device model ID (2 bytes)	0x02 0x55 (TG1260HIII) 0x02 0x45 (TG2460HIII) 0x02 0x53 (TG2460HIII EJC) 0x02 0x44 (TG2480HIII) 0x02 0x50 (TL60III) 0x02 0x51 (TL80III)

n = 0x02, 0x32 Type ID

BIT	OFF/ON	HEX	FUNCTION
0	Off	00	2 bytes characters codes not supported
1	Off	00	Autocutter not supplied
	On	02	Autocutter supplied
2	Off	00	Thermal paper w/o label
	On	04	Thermal paper label
3	-	-	Undefined
4	Off	00	Not used. Fixed to off
5	-	-	Undefined
6	-	-	Undefined
7	Off	00	Not used. Fixed to off



[Notes] This command is executed when the data is processed in the data buffer. Therefore, there could be a time lag between command reception and data transmission, depending on data buffer status.

[Default]

[Reference]

[Example]



0x1D 0x50

<GS P>

Set horizontal and vertical motion units

Valid for	TG1260HIII TG2460HIII, TG2460HIII EJC TG2480HIII TL60III TL80III
[Format]	Hex 1D 50 x y ASCII GS P x y
[Range]	0x00 ≤ x, y ≤ 0xFF
[Description]	Sets the horizontal and vertical motion units to 1/x inch and 1/y inch respectively. When x is set to 0, the default setting value is used. When y is set to 0, the default setting value is used.
[Notes]	<ul style="list-style-type: none">• The horizontal direction is perpendicular to the paper feed direction.• In standard mode, the following commands use x or y, regardless of character rotation (upside-down or 90° clockwise rotation): Commands using x: 0x1B 0x20, 0x1B 0x24, 0x1B 0x5C, 0x1D 0x4C, 0x1D 0x57. Commands using y: 0x1B 0x33, 0x1B 0x4A.• This command does not affect the previously specified values.• The calculated result from combining this command with others is truncated to the minimum value of the mechanical pitch or an exact multiple of that value.
[Default]	x = 0xCC, y = 0xCC
[Reference]	0x1B 0x20 , 0x1B 0x24 , 0x1B 0x5C , 0x1B 0x33 , 0x1B 0x4A , 0x1D 0x4C , 0x1D 0x57
[Example]	



0x1D 0xE6

Virtual paper end limit

Valid for	TG1260HIII TG2460HIII, TG2460HIII EJC TG2480HIII TL60III TL80III
-----------	--

[Format]	Hex	1D	E6	nH	nL
	ASCII	GS	0xE6	nH	nL

[Range]	$0x00 \leq nH \leq 0xFF$ $0x00 \leq nL \leq 0xFF$
---------	--

[Description]	This command sets the limit, expressed in cm as $[(nH \times 256) + nL]$, after which is pointed out the virtual paper-end.
---------------	--

[Notes]

[Default]	nH = 0x00 nL = 0xF0
-----------	------------------------

[Reference]

[Example]	To see the virtual paper-end is pointed out after 15 metres from the first detection of low paper, it's necessary convert 15 metres in 1500 centimetres and then, calculate nH and nL value in the following mode:
-----------	--

$$nH = 1500 / 256 = 5$$

$$nL = 1500 - (nH \times 256) = 1500 - (5 \times 256) = 220$$

and then send the following command:

0x1D 0xE6 0x05 0xDC



0x1D 0xE9

Set minimum ticket length

Valid for	TG1260HIII TG2460HIII, TG2460HIII EJC TG2480HIII TL60III TL80III
-----------	--

[Format]	Hex 1D E9 n ASCII GS 0xE9 n
[Range]	$0x00 \leq n \leq 0xFF$
[Description]	This command sets the minimum ticket length to the n value.
[Notes]	
[Default]	TG1260HIII, TG2460HIII 45 mm TG2460HIII EJC 94 mm TG2480HIII 87 mm TL60III, TL80III 40 mm
[Reference]	
[Example]	To set the minimum ticket length at 56 mm, the command sequence is: 0x1D 0xE9 0x00 0x38



0x1D 0xF0

Set print mode

Valid for TG1260HIII
TG2460HIII, TG2460HIII EJC
TG2480HIII
TL60III
TL80III

[Format] Hex 1D F0 n
ASCII GS 0xF0 n

[Range] $0x00 \leq n \leq 0x02$

[Description] Sets print mode based on the value of n as follows:

n	PRINT MODE
0x00	High quality
0x01	Normal
0x02	High speed

[Notes] Print mode reverts to the default value when the device is reset or turned off.

[Default] n = 0x02

[Reference]

[Example]



ALIGNMENT

1 ALIGNMENT COMMANDS 280



1 ALIGNMENT COMMANDS

Devices listed in this manual are equipped with sensors that allow the use of alignment black mark in order to handle rolls of with pre-printed and fixed length fields.

For further information, refer to the user manual of each device.

The commands available for managing the alignment of the ticket are the following:

- **0x1D 0xE7**: sets the distance between the point of alignment and the black mark (value of “Black Mark Distance” parameter).
- **0x1D 0xF6** and **0x1D 0xF8**: perform the alignment of ticket, which is advanced to cut the ticket at the first alignment point available.

Print a ticket with alignment requires the following sequence of commands:

1. General settings of the ticket (character formatting, print density, margins etc.)
2. Alignment command: **0x1D 0xF6**.
3. Ticket printout (printing text, logos or any graphic).
4. Alignment command: **0x1D 0xF8**.
5. Cut command: **0x1B 0x69**.

The settings take effect from next ticket to the one already in the device.

In the following examples, are described some sequences of commands to manage the alignment.

[Example 1]

Commands sequence to print tickets with “alignment point” set to the edge of the black mark (“Black Mark Distance” parameter = 0 mm set in the setup procedure).

Start
Paper with black mark not aligned.

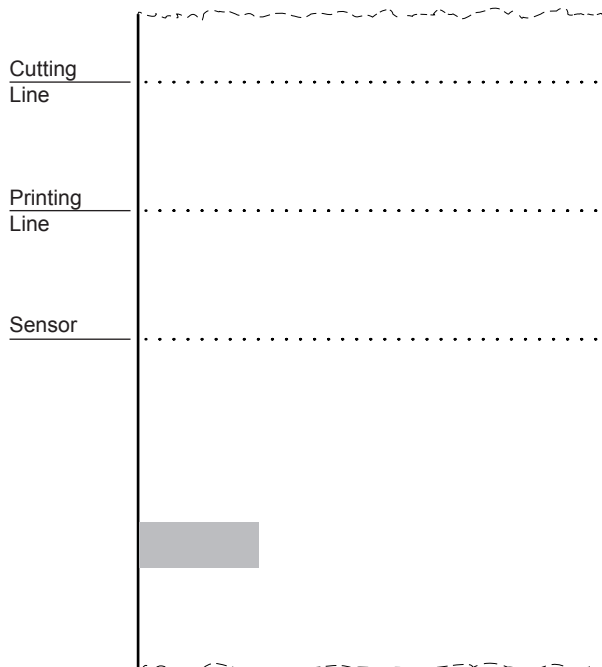

Alignment command `0x1D 0xF6`.
Paper is fed. The black mark is recognized by the sensor and aligned under the printing line.

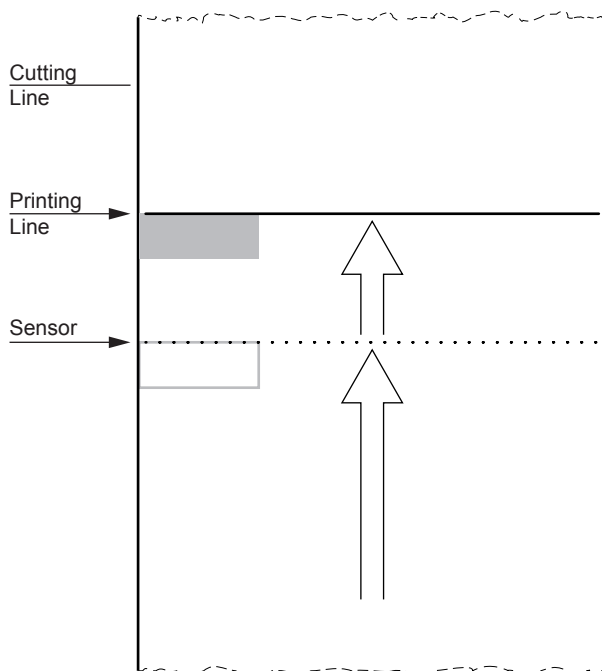



Command for text printing:

'TICKET 1', 0x0A, 'FIRST LINE', 0x0A, 'SECOND LINE', 0x0A

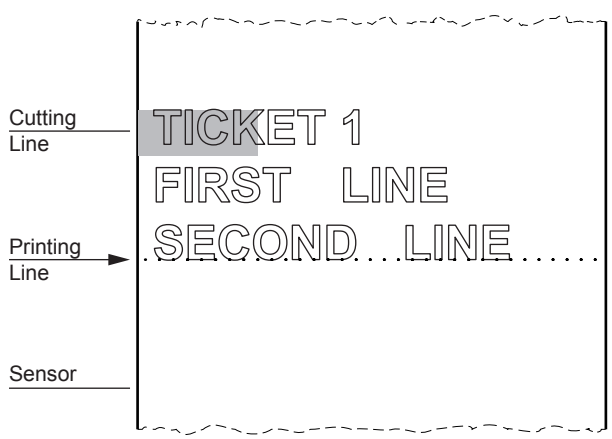

Alignment command 0x1D 0xF8.

Paper is fed. The next black mark is recognized by the sensor and aligned under the printing line.

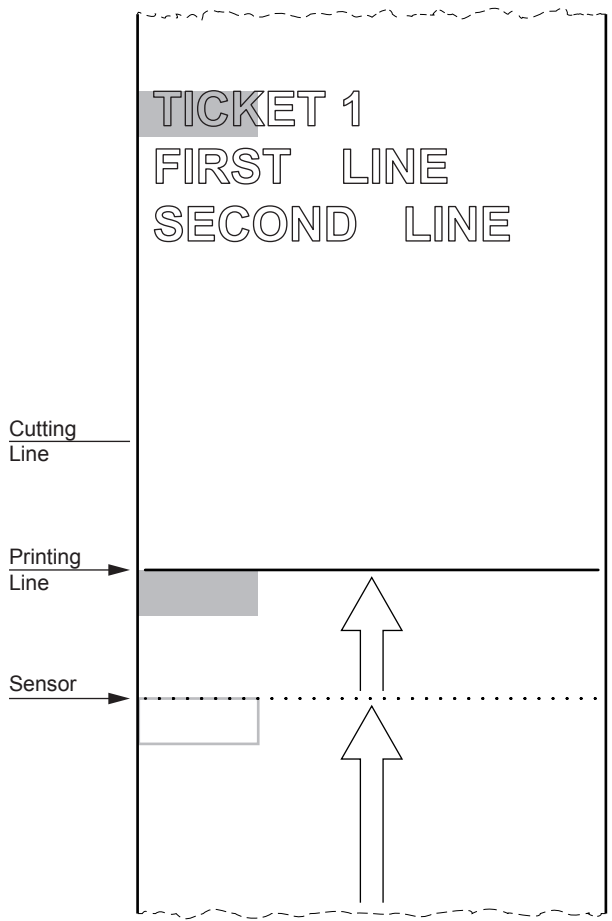



Cut command `0x1B 0x69`.

Paper is fed until the black mark is not aligned under the cutting line.

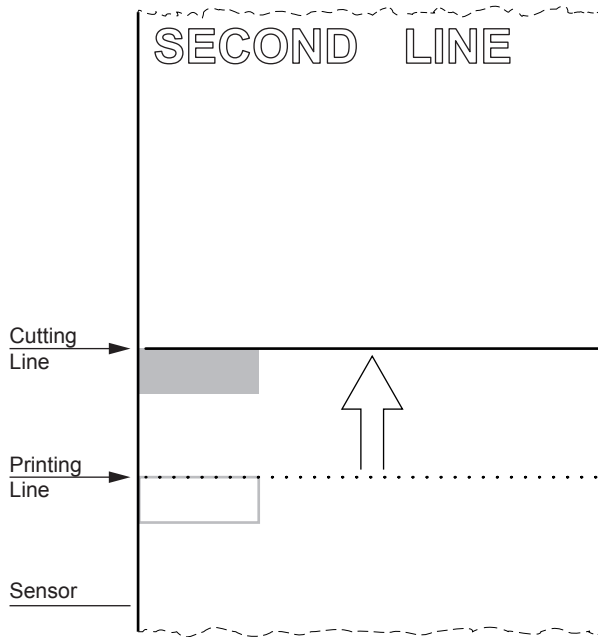

The paper is cut.

The paper is automatically retracted under the printing line.

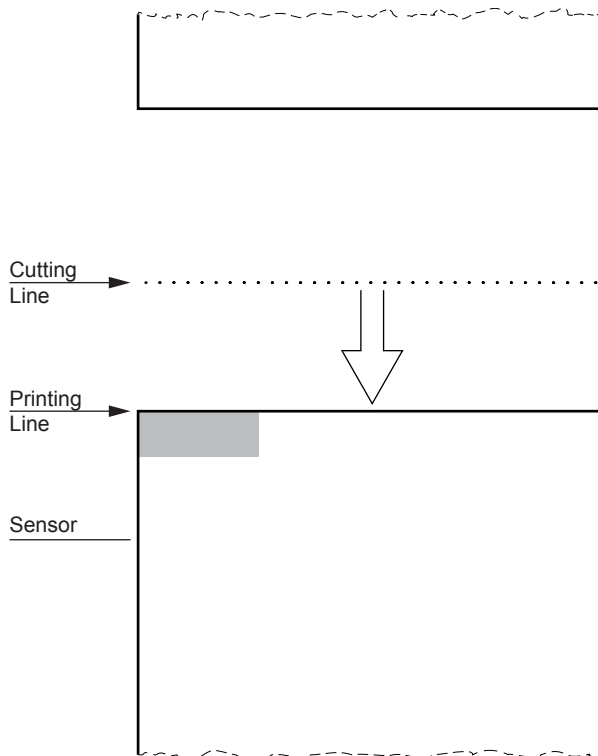



[Example 2]

Commands sequence to print tickets with "alignment point" moved 5 mm compared to the edge of the black mark ("Black Mark Distance" = 5 mm set from setup).

Start.

Paper with black mark not aligned.

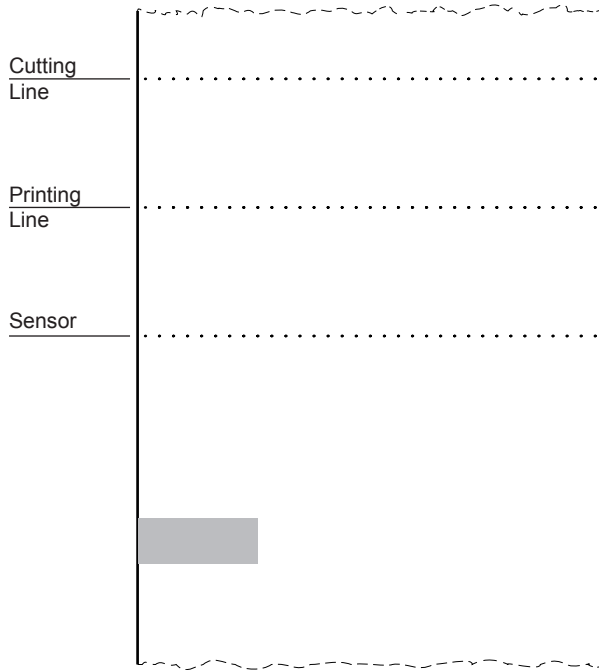

Alignment command `0x1D 0xF6`.

Paper is fed. The black mark is recognized by the sensor and aligned at a distance of 5 mm ("Black Mark Distance") from the printing line.

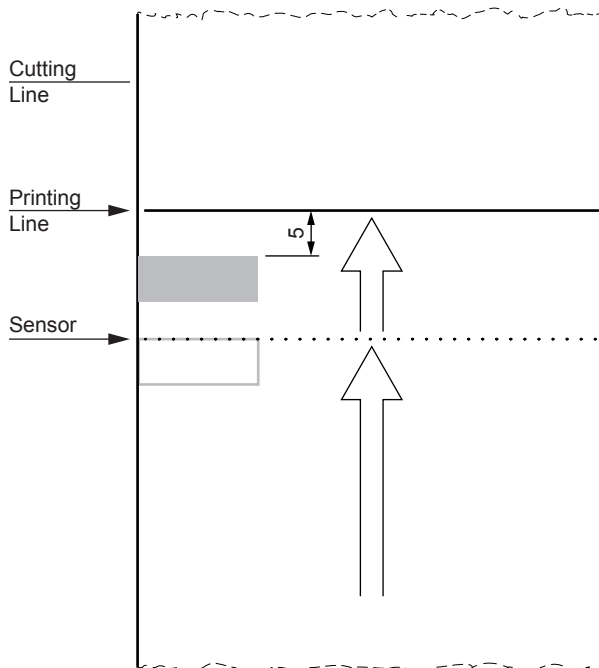



Command for text printing:

'TICKET 1', 0x0A, 'FIRST LINE', 0x0A, 'SECOND LINE', 0x0A

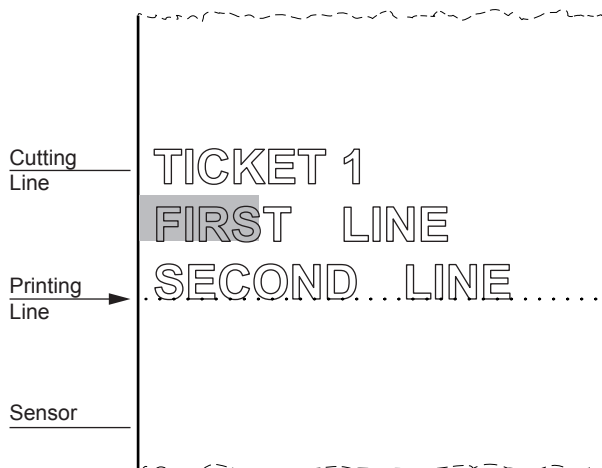

Alignment command 0x1D 0xF8.

Paper is fed. The next black mark is recognized by the sensor and aligned at a distance of 5 mm ("Black Mark Distance") from the printing line.

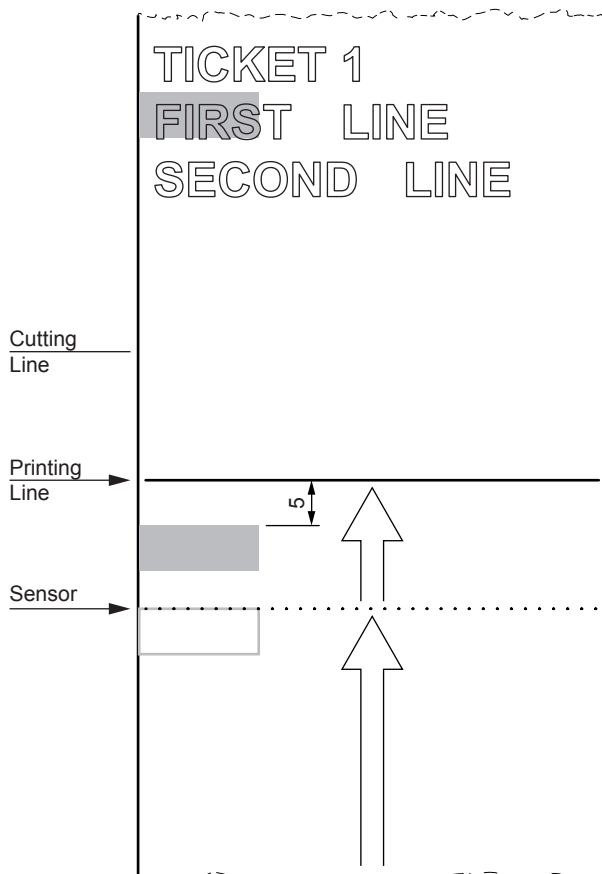



Cut command `0x1B 0x69`.

Paper is fed until the black mark is not aligned at a distance of 5 mm ("Black Mark Distance") from the cutting line.

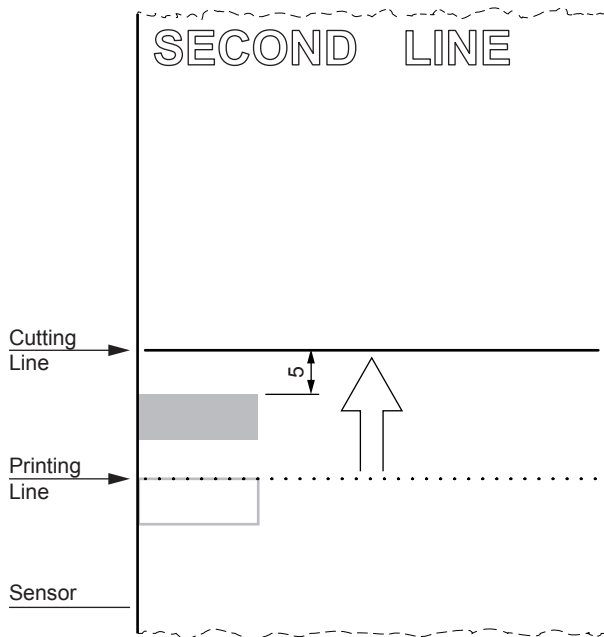

The paper is cut.

The paper is automatically retracted under the printing.

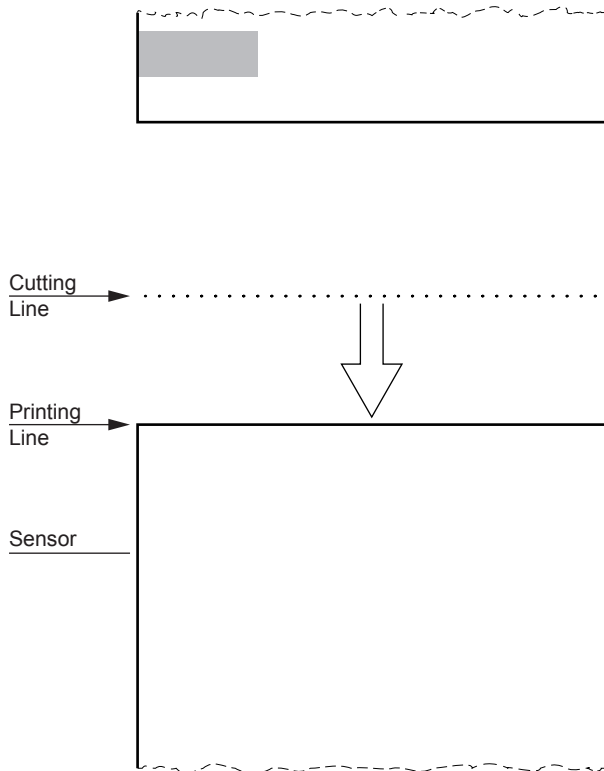







CUSTOM[®]

CUSTOM S.p.A.

World Headquarters

Via Berettine, 2/B - 43010 Fontevivo, Parma ITALY

Tel. +39 0521 680111 - Fax +39 0521 610701

info@custom.biz - www.custom.biz

All rights reserved

www.custom.biz